

PART NUMBER:
025-G010

PART NUMBER:
025-G010

JOB NUMBER:

A

BLUE GIANT EQUIPMENT CORP.

85 Heart Lake Road South
Brampton, Ontario, L6W 3K2
Tel: 905-457-3900
Fax: 905-457-5586



PROPRIETARY AND CONFIDENTIAL

THE INFORMATION CONTAINED IN THIS DRAWING IS THE SOLE PROPERTY OF BLUE GIANT EQUIPMENT CORPORATION. ANY REPRODUCTION IN PART OR AS A WHOLE WITHOUT THE WRITTEN PERMISSION OF BLUE GIANT EQUIPMENT CORPORATION IS PROHIBITED.

DIMENSIONS ARE IN INCHES
TOLERANCES:
FRACTIONAL 1/32
ANGULAR: MACH .5 BEND 2
ONE PLACE DECIMAL 0.015
TWO PLACE DECIMAL 0.010
THREE PLACE DECIMAL 0.005

THIRD ANGLE PROJECTION

DESCRIPTION

BLUE GENIUS CONTROL BOX WITH MOUNTING BRACKETS

DWG. NO.

025-G010-A

FOR:

REF.

APPROX. WEIGHT (lb.):

SCALE: 1:4 **SIZE A**

MATERIAL

MATERIAL NO

	NAME	SIGNATURE	DATE
DRAWN	KP		
DESIGN			
ENG APPR.			
MFG APPR.			
Q.A.			

COATING:

FINISH:

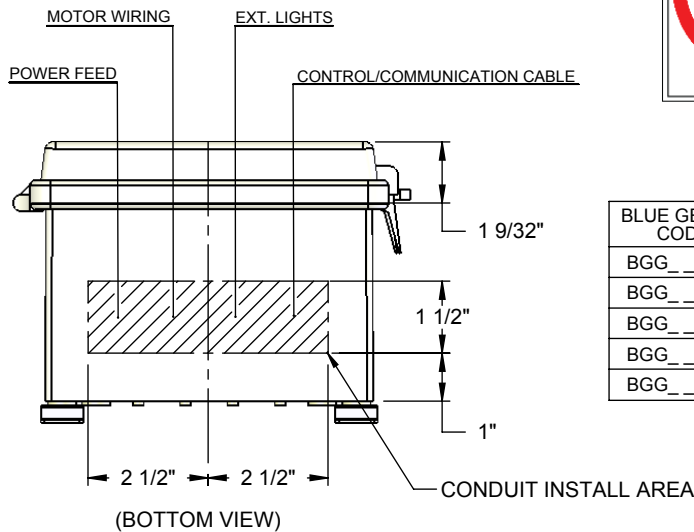
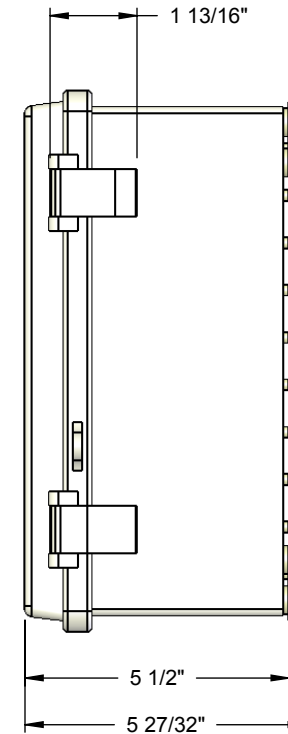
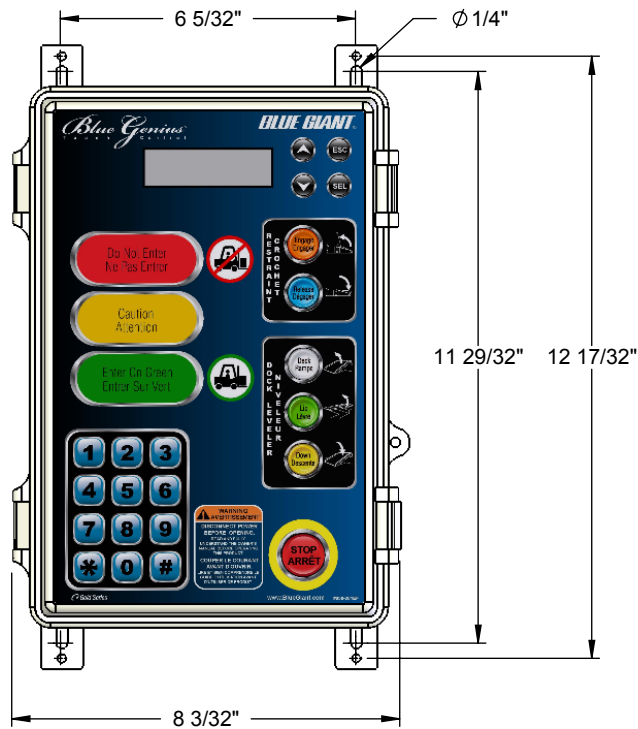

BLUE GENIUS CODE	PHASE (PH)	VOLTAGE RANGE (V)	FREQUENCY (hz)
BGG_ 1115	1	110-130	50/60
BGG_ 1230	1	208-240	50/60
BGG_ 3230	3	208-240	50/60
BGG_ 3460	3	380-480	50/60
BGG_ 3575	3	575-600	60



NOTE:
INSTALL HIGH POWER CONDUIT FROM BOTTOM PANEL.