

Series BG150

fixed inflatable dock seal

BLUE GIANT®

Designed for 8' x 8' (2438mm x 2438mm) door openings, the BG150 series fixed inflatable dock seal combines a unique internal baffle system with a durable air bag construction to increase contact area and lower energy costs.

Benefits

- SAVE hundreds of dollars in reduced energy costs
- IMPROVE working conditions by keeping dust, dirt, debris and insects out
- PROTECT product and personnel from harsh weather conditions
- INCREASE productivity by providing a safe and comfortable working environment
- DURABLE range of Hi-Performance fabrics to choose from
- CUSTOM sizes available



Standard Size Specifications

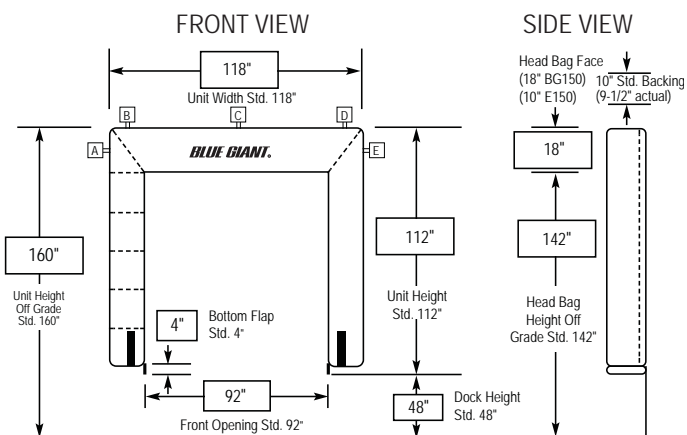

Generally designed to suit 8' wide x 8' high (2438mm x 2438mm) openings.

The BG150 series reduces pressure against the building wall unlike conventional pads while creating a tight energy saving seal against the back of the truck.

A one piece air bag construction with a unique internal baffle system creates a square faced design increasing contact area. This design ensures that off-centre trailers and even trailers that are not spotted square to the opening are sealed.

fixed inflatable dock seal

Blue Giant offers a wide variety of custom inflatables to satisfy your dock requirements.

- Square faced design creates larger contact area against truck
- Pressure treated non-rot wood framing
- 24" yellow guide stripes for accurate truck placement
- Externally mounted motor with galvanized protective hood
- Higher wedged header design seals a variety of trailers
- Custom sizes and projections available
- Available in 22oz Hi-Tear Vinyl or rugged 16oz Hi-Tear Hypalon

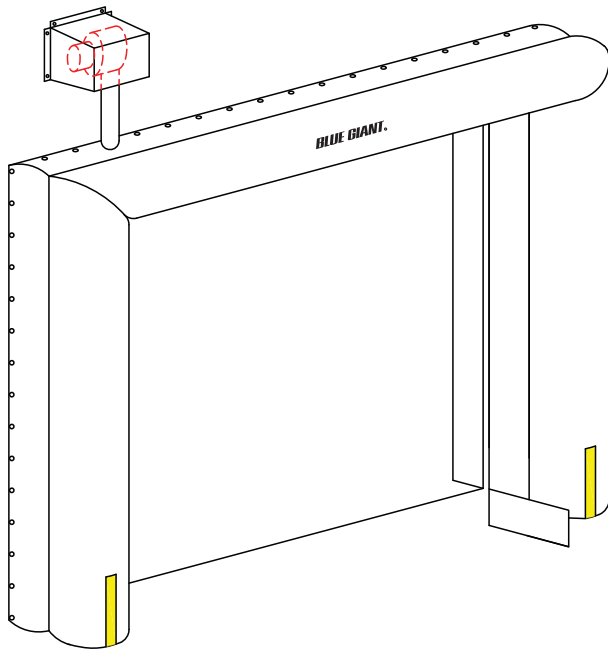
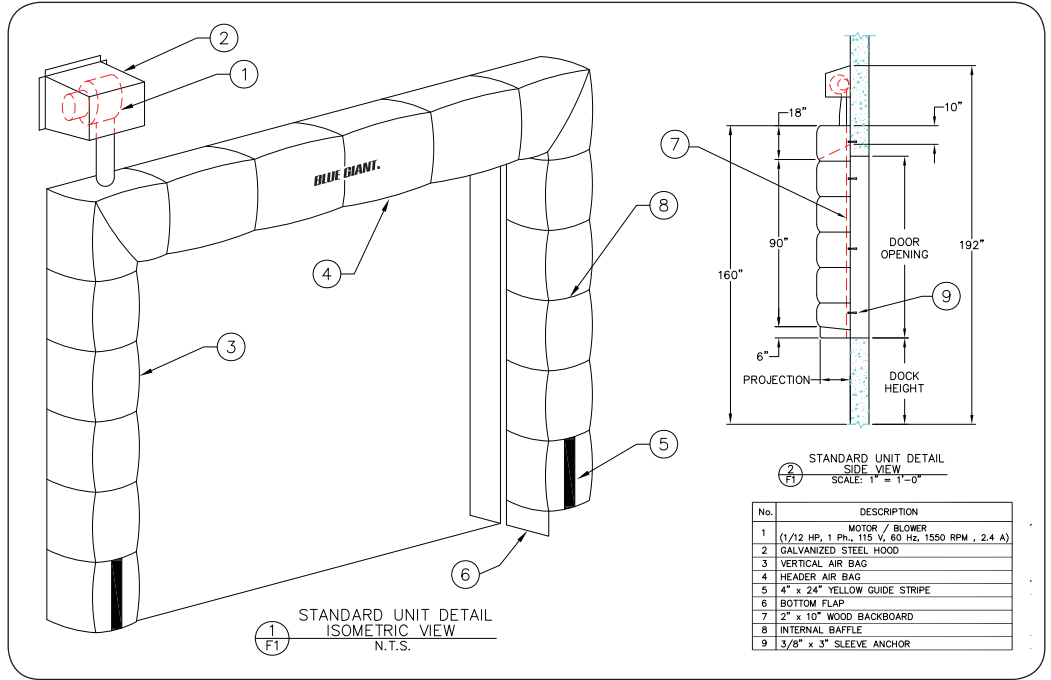

Also available is the E150 with bubble design on header and sides.

Customize Your Dock to Suit Your Specific Needs

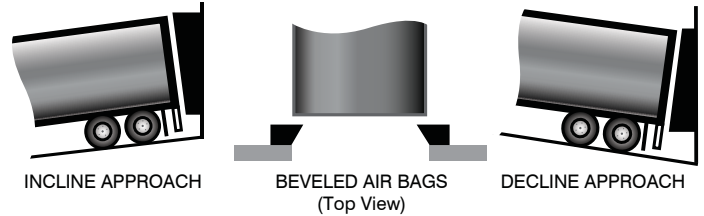

Fabric and Colour Selection

Blue Giant can customize your dock seal with the ideal fabric for your application from a wide range of colours and fabrics available.

- 14oz Hi-Tear Vinyl
- 22oz Hi-Tear Vinyl
- 32oz Hi-Tear Vinyl
- 40oz Hi-Tear Vinyl
- Hi-Performance Arctic Seal
- 16oz Hi-TearHypalon
- 40oz Hi-Performance Hypalon

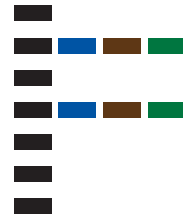

85 Heart Lake Road South
Brampton, Ontario, Canada L6W 3K2
Phone: 905-457-3900 · Fax: 905-457-2313
www.BlueGiant.com

AUTHORIZED DISTRIBUTOR

BLUE GIANT EQUIPMENT CORPORATION

BLUE GIANT offers a full line of dock levelers, dock safety equipment, accessories, ergonomic and scissor lift equipment and industrial trucks. Concurrent with our continuing product improvement program, specifications are subject to change without notice. Please contact BLUE GIANT for latest information. Some features illustrated may be optional in certain market areas.