

Designed for 10' x 10' (3048mm x 3048mm) door openings, the BG500 retractable shelter series creates a tight, energy-efficient seal and retracts on impact, reducing pressure on the curtains and extending the working life of the shelter.

## Benefits

- SAVE hundreds of dollars in reduced energy costs
- IMPROVE working conditions by keeping dust, dirt, debris and insects out
- PROTECT product and personnel from harsh weather conditions
- INCREASE productivity by providing a safe and comfortable working environment
- DURABLE range of Hi-Performance fabrics to choose from
- CUSTOM sizes available



### Standard Size Specifications

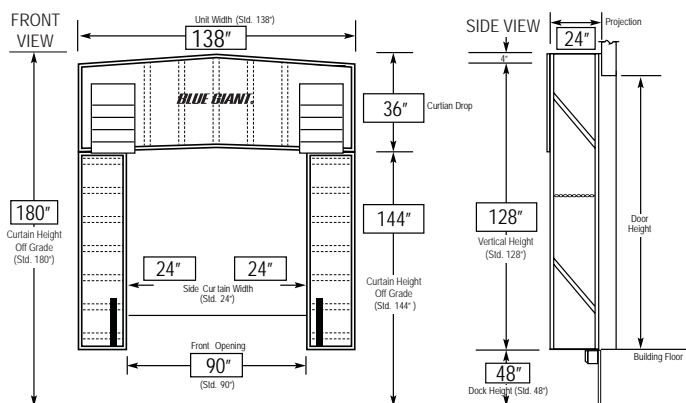

Generally designed to suit 10' wide x 10' high (3048mm x 3048mm) openings.

The BG500 series provides full access to the rear of the trailer while creating a tight seal against the top and rear of the trailer. The collapsible frame is designed to retract upon impact from the trailer thus reducing pressure against the curtains and extending the life of the unit. This also allows for less pressure against the building wall.

With one of the largest selections and colours of fabrics available, Blue Giant can offer the ideal solution for your unique loading dock requirements.

Blue Giant offers a wide variety of custom shelters to satisfy your dock requirements.

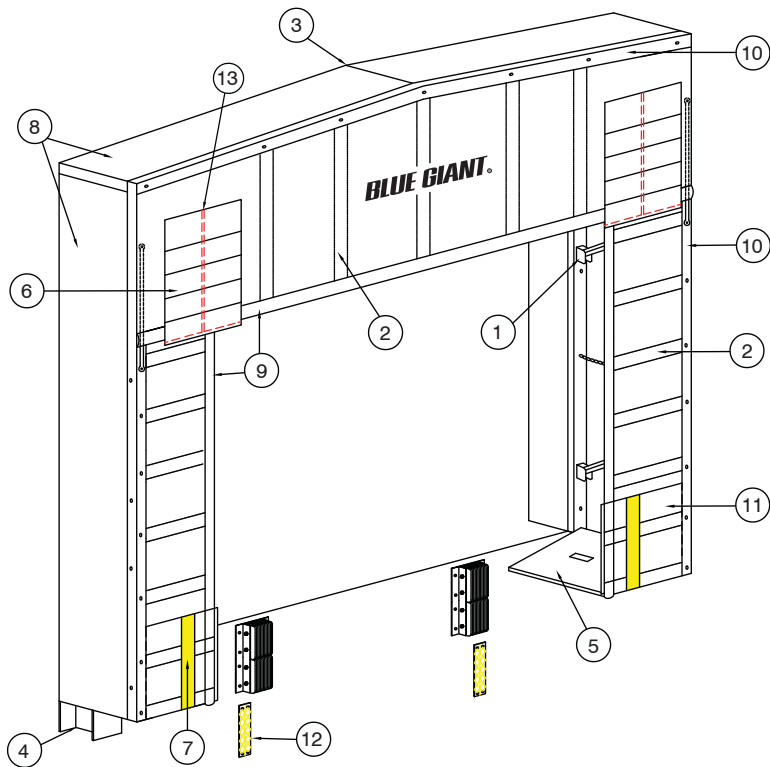

1. Galvanized tubular framing
2. Stiffeners in head and side curtains help to maintain constant pressure against trailer ensuring a tight seal
3. Raked head frame diverts water to sides
4. Protective "I" beam
5. Replaceable foam bottom pads seal gap between truck and building
6. Protective wear flaps on head curtain help to extend life of unit
7. 24" yellow guides ensure accurate placement of trucks
8. 19 oz black vinyl
9. Foam filled edge creates a complete seal against truck
10. Galvanized trim angle will not rust
11. Double layer of protective fabric on bottom 24" of side curtains
12. Optional "reflective guides" to protect your investment
13. Optional gusset available (strongly recommended)

### Customize Your Dock to Suit Your Specific Needs

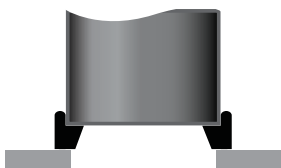

(Top View)

Conventional foam pads protect against weather, but restricts access to the trailer opening.

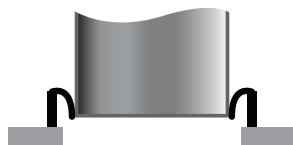

(Top View)

Blue Giant's D500 retractable shelter provides full access to the rear of the trailer.

### Fabric and Colour Selection

Blue Giant can customize your dock seal with the ideal fabric for your application from a wide range of colours and fabrics available.

- |                              |         |
|------------------------------|---------|
| 22 oz Hi-Tear Vinyl          | ■ ■ ■ ■ |
| 32 oz Hi-Tear Vinyl          | ■       |
| 40 oz Hi-Tear Vinyl          | ■ ■ ■ ■ |
| Hi-Performance Arctic Seal   | ■       |
| 16 oz Hi-Tear Hypalon        | ■       |
| 40 oz Hi-Performance Hypalon | ■       |



85 Heart Lake Road South  
 Brampton, Ontario, Canada L6W 3K2  
 Phone: 905-457-3900 · Fax: 905-457-2313  
 www.BlueGiant.com

AUTHORIZED DISTRIBUTOR

BLUE GIANT EQUIPMENT CORPORATION

BLUE GIANT offers a full line of dock levelers, dock safety equipment, accessories, ergonomic and scissor lift equipment and industrial trucks. Concurrent with our continuing product improvement program, specifications are subject to change without notice. Please contact BLUE GIANT for latest information. Some features illustrated may be optional in certain market areas.