

CS-201

compression seal with adjustable header

BLUE GIANT®

Forms an air-tight seal between building and trailers that vary in height

Designed to work best where doors are over 9' (2743 mm) high and/or where trailers vary in height, the CS-201 is an economical way to form an air tight seal between the building and trailer for dock openings up to 10' wide x 12' high (3048 mm x 3658 mm). For added versatility the CS-201 is also available with an adjustable head curtain that can be easily positioned by one person from inside the building by means of rope and pulley after the trailer is in position. The resilient foam pads can be covered with a large selection of tough abrasion resistant fabric, creating a tight seal that blocks foul weather, insects and dust, while saving money on energy costs. The CS-201 dock seal will also protect personnel, product and equipment while increasing comfort, safety and productivity.



- Adjustable curtain for trailers with varied height.
 - Backing is made with the highest quality pressure treated wood.
 - Custom sized to insure a perfect seal.
 - Long lasting and low maintenance.
 - Galvanized steel mounting brackets.
- Adjustable "split" curtain is an available option.

- Yellow guide stripe is vulcanized (heat sealed) not sewn in.
- Long lasting high quality vinyl with U.V. stabilized to prevent fading.
- No structure to crush, high density memory foam compresses on all sides reducing damage.

OPTIONS

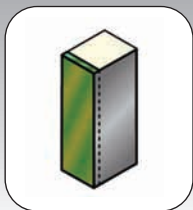

A. Cover material overlaps edges only



B. Protective flaps (4", 8", 16" (101, 203, 406 mm) exposure)

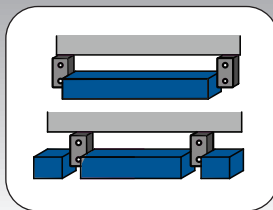

C. Bottom seal

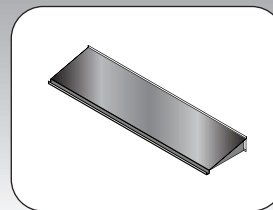

D. Galvanized steel canopy

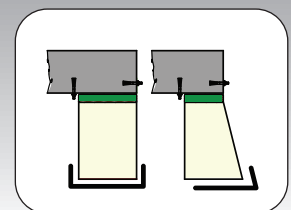

E. Double layer on impact area

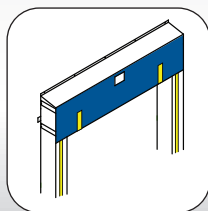

F. Split curtain

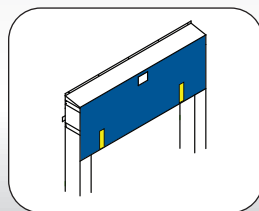

G. Longer drop curtain

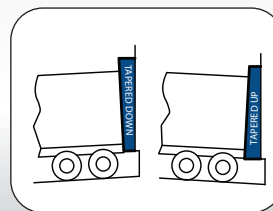

H. Tapered units

I. Beveled vertical pads
Models:
8/11
12/15
18/18
8/20

CS-201 Product Details

- CS-201 standard dimensions for door openings 8' wide x 10' high (2438 mm x 3048 mm) has (2) two 10' (3048 mm) high vertical pads with a 12" (305 mm) face, wedge shape and (1) one 10' (3048 mm) long head curtain with a 24" (610 mm) drop. Unit projection to be 10" (254 mm).
- Seals trailer(s) 12' (3658 mm) to 13'6" (4114 mm) high from grade with a dock height of 48" (1219 mm).
- A large selection of cover fabrics available including our exclusive SS-90-1 high performance vinyl. Other available fabrics include hypalon and other vinyls. (SEE MATERIAL SELECTION GUIDE).
- Can be fitted for openings up to 10' (3048 mm) wide. x 12' (3658 mm) high by the use of wedge shaped verticals and longer curtain.
- 4" - 6" (102 mm - 152 mm) pad projection in front of the dock bumper face is recommended to prevent over-compression, excessive wear & tear and undue building wall pressure.

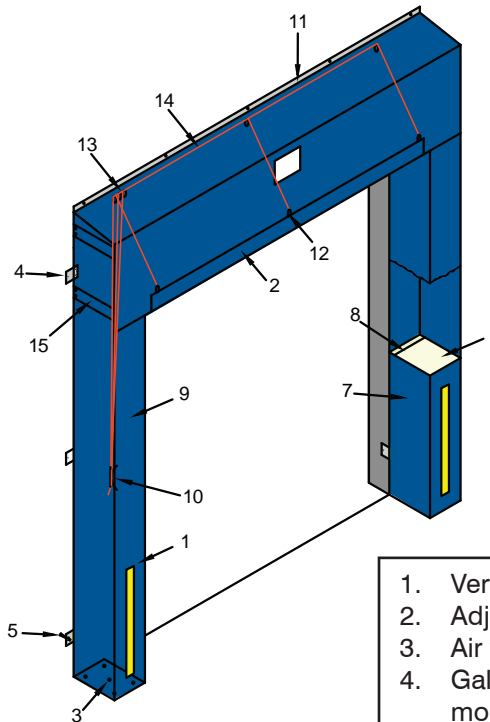

- | | |
|-----|------------------------------------|
| 1. | Vertical pad |
| 2. | Adjustable head curtain |
| 3. | Air vents |
| 4. | Galvanized steel mounting brackets |
| 5. | Sleeve anchor bolts |
| 6. | Polyurethane foam core |
| 7. | Cover fabric |
| 8. | Pressure treated wood backing |
| 9. | 4" wide yellow guide stripe |
| 10. | Rope cleat |
| 11. | Head curtain retaining bar |
| 12. | "D" rings |
| 13. | Pulleys |
| 14. | Rope |
| 15. | Head curtain restraining straps |

Dock door seal(s) to be Series CS-201 as manufactured by Super Seal Mfg. Ltd., Woodbrige, Ontario. Dock door seal(s) to be manufactured to fit door opening size ____ ft. wide x ____ ft. high. Vertical pads to be manufactured using kiln-dried wood and high grade, dense, light weight urethane foam core with 98% copression recovery and maintaining flexibility at -40° (fire retardant formula available; please specify). Foam core shall be continously bonded (not spot glued) to the wood backing with a industrial, non-flammable elastic adhesive. Cover fabric shall be double stitched with high strength twisted 4 ply 100% polyester bonded, U.V. treated thread. Cover fabric overlaps wood backing totally enclosing it and fastened with heavy duty plated staples. Vertical pads are vented through brass plated grommets allowing air to be exhausted and moisture to drain. Vertical pads are tapered cut at top to provide adequate drainage. Vertical pads have a 24" (610 mm) high 4" (102 mm) wide yellow guide stripe to aid in visability. Unit shall come complete with a droop curtain over vertical pads. Full width steel tube shall be inserted into a pocket on the head curtain to prevent sagging. Curtain is manually adjusted by means of rope and pulley assembly. Unit shall be furnished with galvanized mounting hardware to resist corrosion.



85 Heart Lake Road South
 Brampton, Ontario, Canada L6W 3K2
 Phone: 905-457-3900 • Fax: 905-457-2313
www.BlueGiant.com

AUTHORIZED DISTRIBUTOR

BLUE GIANT EQUIPMENT CORPORATION

BLUE GIANT offers a full line of Loading Dock Equipment including Dock Levelers, Vehicle Restraints, Dock Seals and Shelters and Material Handling Solutions. Concurrent with our continuing product improvement program, specifications are subject to change without notice. Please contact BLUE GIANT for latest information. Some features illustrated may be optional in certain market areas.