

StrongArm™ SVR303

Vehicle Restraint System

BLUE GIANT®

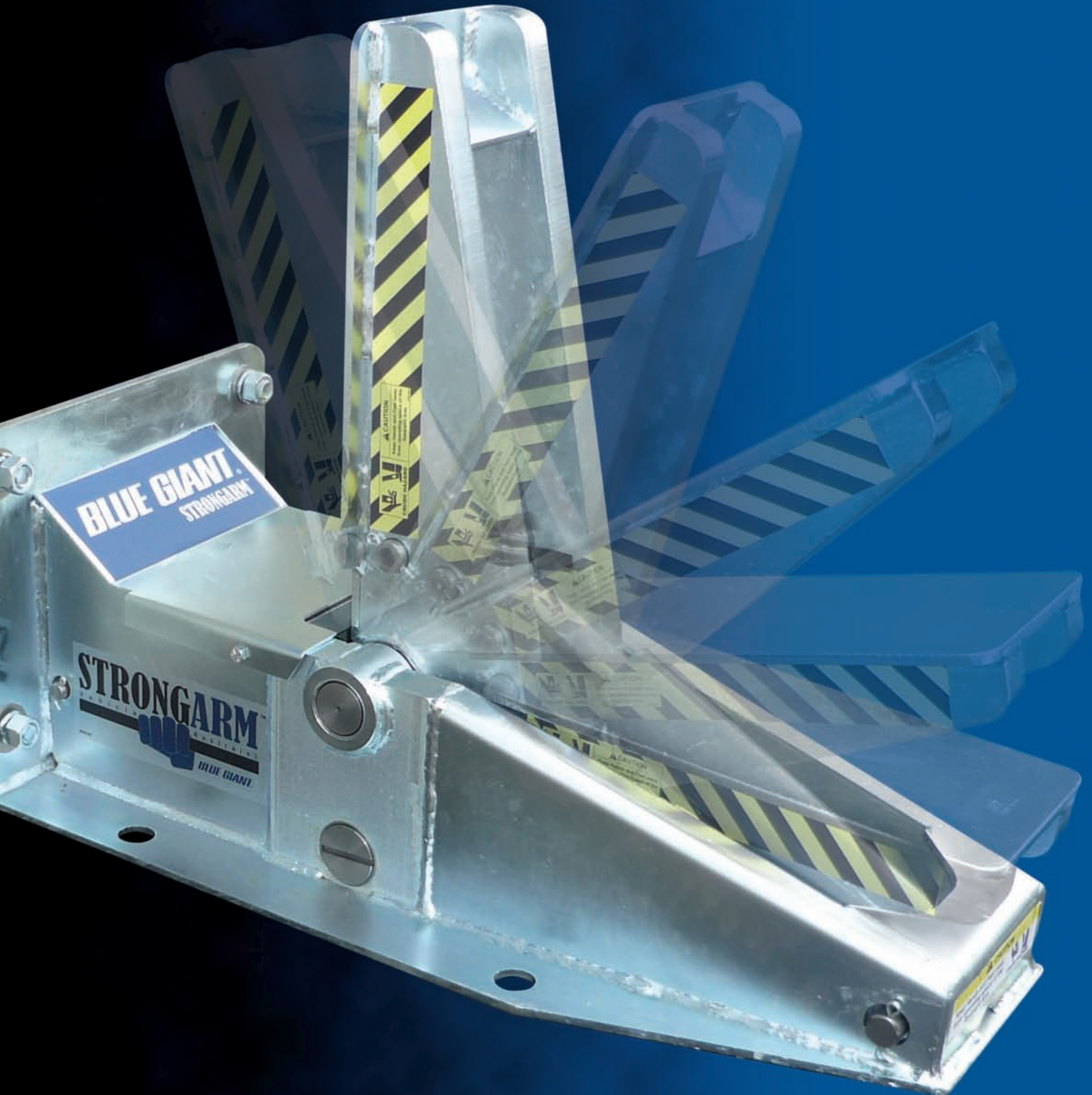

Superior Technology Blue Giant Advantage

1 Largest Restraining Range: From 8" to 26" above ground and up to 12" from the face of the wall and effective when wall bumpers are worn down or missing. The StrongArm™ also restrains damaged, bent and closed-in rear impact guards caused by traffic accidents or damage from other impact type restraints.

2 Blue Genius™ Touch Controls: Incorporates accurate proximity sensing of the operator's finger within the low level electric field range. **Onboard Diagnostics and Communications** within the panel features a user-friendly, LCD screen that provides real time, easily understood instructions for operation, maintenance and diagnostics as well as supervisory keypad lockout and override function. **Microprocessor Based Controls** offer advanced technology and intelligent programmable menu options. Provides flexibility at the software level and is easily upgradable. **Printed Circuit Board Technology** provides trouble free wiring and simplified board level troubleshooting with quick up time response eliminating time consuming multi-meter diagnostics. **Power Protection** for the low power control, ensures safe field wiring. The panel is safeguarded against potential shock hazard when opened. The system features a power shut down and short circuit protection. **Network Connections** provides bidirectional communication and power wiring. This technology surpasses conventional relay wiring methods eliminating wiring errors between the controller and power pack.

3 LED Traffic Lights & Communication Package: Bright LED traffic lights communicate safe and unsafe conditions and when operating during supervised override mode. To detect positive locking of the restraint, exterior traffic lights turn red and interior traffic lights turn green indicating it is safe to proceed with docking operations. If contact is not made with the vehicles rear impact guard during the cycle rotation, the restraint is automatically restored and signals the operator and driver of cautionary or unsafe conditions with inside flashing yellow and outside red. The communication system is complete with audible alarm, coded override and real time LCD display providing simple trouble shooting and self-diagnostics to safely deal with all loading dock conditions. The non interchangeable lights provide reliable product functionality and also minimize improper use. Lights are bright and long lasting LED type with 100,000 hour ratings.

4 Intelligent Positioning System The StrongArm™ features our advanced switchless Intelligent Positioning System. Upon locking the StrongArm™, the electronic sensing device communicates to the control panel of the positive 90 degree secured position and provides integrated communication with the lights system. No false sensing or premature next level light signaling is allowed with the Intelligent Positioning System. Added reliability is assured with the absence of mechanical switches that are typically prone to maintenance and adjustment. The self-calibrating Intelligent Positioning System ensures accurate reading and positioning at all times.

5 Supervisory Keypad with Controlled Override/Security Operation: If no rear impact guard is present or detected during the restraints rotation, or the Intelligent Positioning System stops before 90 degrees, the system will return the restraint to its original stored position. By activating the supervisory keypad; exterior traffic lights stay red, interior traffic lights will change from red to green with flashing cautionary yellow identifying extra awareness and precautions to be taken e.g. chocking wheels. For added safety, the panel is equipped to provide supervisory personnel with security lockout/override which restricts disengagement of restraint to authorized users with security code access only.

6 Non-impact Design: The incredible low profile allows the rear impact guard to clear the restraint body during arrival to or departure from the loading dock causing no physical or costly damage to either the trailer or the restraint itself. The SVR303 StrongArm™ is compatible with air-ride suspension trailers that can easily change working heights once the air is released. Unlike other restraints, the SVR303 StrongArm™ does not lose restraining engagement from loading or unloading vibrations that forces restraints to lock up or forced out of position due to upward or forward movement of the rear impact guard - a common problem with other systems that require 100% contact to "float" with trailer movement.

Patented switchless technology

7 No Lock-up Problems: Not susceptible to locking pressures from nominal movement of the rear impact guard. Double acting cylinders ensure proper engagement and disengagement when required.

8 Minimal Maintenance Costs: No lubrication or adjustments and the fewest moving mechanical parts of any comparable restraint in the market with only 2 dual-acting hydraulic cylinders provides lifetime cost effective ownership. There is no proximity or mechanical switches to maintain or replace. There is no raised collared control buttons to wear out or replace. No rollers, carriage, springs or other wear items to maintain, replace or align from constant movement or impact. Self-lubricating bearings and bushings provide high performance and long lasting operation. No special tools are required to service. In traditional Blue Giant® fashion, we offer simplicity and well engineered designs that provide for low cost replacement components (if required) and product longevity.

9 Easy to Install: Wall or ground mounted flexibility to accommodate for various applications and driveway designs. Installation is therefore not limited; the restraint can be mounted/anchored to a concrete foundation wall (new pour or retrofitted to existing) with an asphalt drive apron or retrofitted to an existing building with cinder block foundation and a concrete drive

apron, either way the SVR303 StrongArm™ is designed to be fastened at the loading dock bay. Network connections provides bidirectional or interchangeable communication and power wiring. Control panels require no cumbersome electrical hook up and are polarity free. Just plug and play. Optional projection boxes available for projected pit and/or edge of dock applications. Unit can be integrated with Blue Giant® or other market brand dock levelers.

10 Below Dock Level Compatible: Unlike wall mounted designs that sit high and float with trailer movement, the SVR303 StrongArm™ body is clear from and does not impede with or damage the dock leveler lip for those common instances where below level, end loading operation or in the presence of a low dock height application. This is an important feature that provides worry free consideration of accidentally disengaging the locking mechanism that may be common from lip contact from other type restraint designs.

11 Theft deterrent: The SVR303 StrongArm™ restraint can be left engaged overnight providing added security at the loading bay. The offering comes with optional tamper proof locking devices and hardware to prevent temptation from criminal or vandal activities.

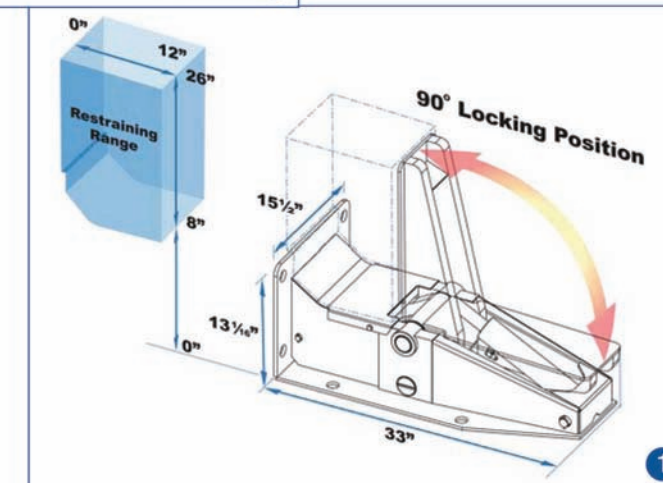

Superior Features Blue Giant® Advantage

- 35,000lb restraining strength and 100,000lb mounting force – the transfer of pulling force down to the driveway improves restraining strength by equalizing forces on the anchors.
- Low profile restraint body - only 8" high from the ground that can service a multitude of trailer rear impact guard positions. For international trailers or special under-chassis configurations, consult factory for optional accessories.
- Vertical restraining from 8" to 26" above grade with minimum 4" contact space required.
- Horizontal restraining range up to 12" from the face of the dock.
- Intelligent Positioning System to ensure positive location sensing; from 0 degrees to maximum full rotation to ensure accurate reading of the restraint StrongArm™ and locking mechanism.
- Blue Genius™ Gold Series II, 24 volt panel, with touch control technology for engage or disengage and reset. NEMA4X (IP65) enclosure rating.
- Advanced communication package includes LED interior red/yellow/green and exterior red/green traffic lights, signs and programmable audible alarm.
- Onboard diagnostics and communications feature a user-friendly, multi-language LCD intelligent text display and keypad with supervisory override.
- Stop button provides complete motion freeze of restraint and interlocked components.
- Double acting, chrome coated cylinders and self-lubricating bushings and bearings for maximum protection from debris and ensures reliable movement of the securing components.
- Wall or ground mounting capabilities to meet varying site conditions.
- (4) Heavy-duty wedge anchor bolts 3/4" x 6" long.
- 1HP high performance power pack remotely mounted inside the building or under the dock leveler protected from harsh exterior elements and easy maintenance accessibility.
- Zinc plated provides anti-rusting (corrosion) properties and long product life.
- UL/CSA/CE approved components.
- 5 year structural, 2 year electric/hydraulic warranty.



85 Heart Lake Road South
Brampton, Ontario, Canada L6W 3K2
Phone: 905-457-3900 • Fax: 905-457-2313
www.BlueGiant.com

AUTHORIZED DISTRIBUTOR

BLUE GIANT EQUIPMENT CORPORATION

BLUE GIANT offers a full line of Loading Dock Equipment including Dock Levelers, Vehicle Restraints, Dock Seals and Shelters and Material Handling Solutions. Concurrent with our continuing product improvement program, specifications are subject to change without notice. Please contact BLUE GIANT for latest information. Some features illustrated may be optional in certain market areas.