

PDS30 Power Drive Straddle Trucks

Short turning radius makes it an excellent choice for narrow aisles, tool rooms or street level loading

CAPACITY

3000 lbs (1360 kg) at 24" (610mm) load center

BATTERY

Compartment: 26.37" (670mm) x 9.1" (231mm) x open.
Anderson 175 Gray—A-11 Minimum battery weight 480 lbs (218 kg).

SPEED

TRAVEL

Variable from 0 mph to 3.4 mph empty
Variable from 0 mph to 3.1 mph loaded

LIFT

Up to 40 fpm empty.
Up to 35 fpm loaded – 3000 lbs (1360 kg)

TIRES

DRIVE

9" x 3" (229 x 76mm) polyurethane

LOAD

4" x 2.9" (102 x 74mm) polyurethane

HYDRAULICS

Lift cylinder has hard chrome plated rods. Pump unit including motor, solenoid, gear pump, and pressure compensated lowering valve are mounted high in the power compartment for ease of service.

ELECTRICAL

24-Volt ZAPI AC O inverter, travel control with matching drive motor provide high performance throughout the entire speed range. Travel speed remains constant relative to throttle position regardless of load. Separately fused power control circuits, quick disconnect EPD power cut off, hour meter / battery discharge indicator combination gauge complete the system. Power configurations and diagnostic features are displayed with a ZAPI handheld console.

BRAKES

Regenerative electromagnetic brake is mounted on motor armature shaft multiplying the braking power through the ZF GK10 transmission. Brake is applied when control arm is in the vertical or horizontal handle position. System features anti-roll back and neutral braking.

TILLER ARM CONTROLS

Travel, lift, and lower functions are located in the ergonomic operator handle. All operator controls are accessible without having to lift the hand from the handle. Angle grips are designed to allow easy operation with either hand. Wrap around guard, reversing switch, thumb control, and horn are standard. Low mounted tiller arm offers excellent operator comfort and minimum steering effort. Gas assisted spring handle gently returns handle to vertical position. Crawl speed function with steer handle at 5° back-tilt from vertical allows for ease of use in tight areas.

TRANSMISSION

Vertically mounted drive motor is direct mounted to gear housing. Oil bathed ZF GK10 hypoid bevel gear drive train with tapered roller bearings transfers power to axle. State of the art optimized gear technology supplies advantages such as minimal envelope circle, zero maintenance, low noise level, high efficiency and high performance.

LOWERING

Up to 29 fpm empty.
Up to 57 fpm loaded –
3000 lbs (1360 kg)

WEIGHT

2539 lbs (1360 kg)
Chassis only



ACCESSIBILITY

Removal of two piece power head cover exposes major components for inspection and maintenance.

FRAME AND MAST

Bolt-on high visibility mast, I-beam construction, lift cylinders positioned in outer I-beam for best view through mast.

Three inch wide adjustable straddle legs allow ease of use in racked aisles. Straddle leg inside dimension (ID) can be set at 38" (965mm) to 50" (1270mm) in 4" (102mm) increments; 42" (1067mm) to 50" (1270mm) with the triple stage mast.

Class II ITA fork carriage with 36" (914mm) tall load back rest. Forks are adjustable from 8" (203mm) ID to 30" (762mm) OD.

STANDARD EQUIPMENT

- Crawl speed travel control
- Wrap around steel bumper
- Neutral braking
- Two speed lower
- Programmable performance travel / plugging / braking

OPTIONAL EQUIPMENT

- 36" (914mm) long forks
- 48" (1219mm) long forks
- 48" (1219 mm) tall load backrest
- Cold conditioning
- Maintenance free battery pack (4) 6V AGM 224 AH / 5.4 kWh integral 110V AC plug-in charger
- 24V wet celled industrial battery 255 AH / 5.9 kWh



Dimensions

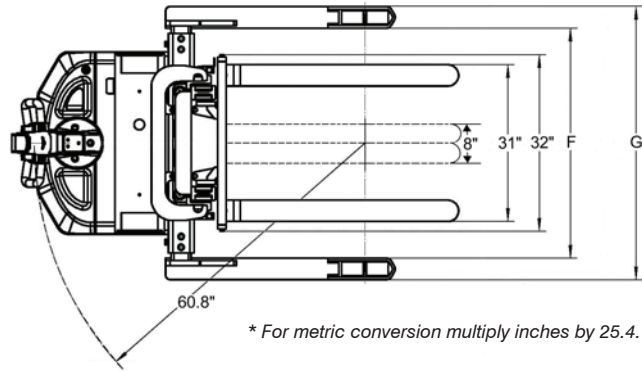
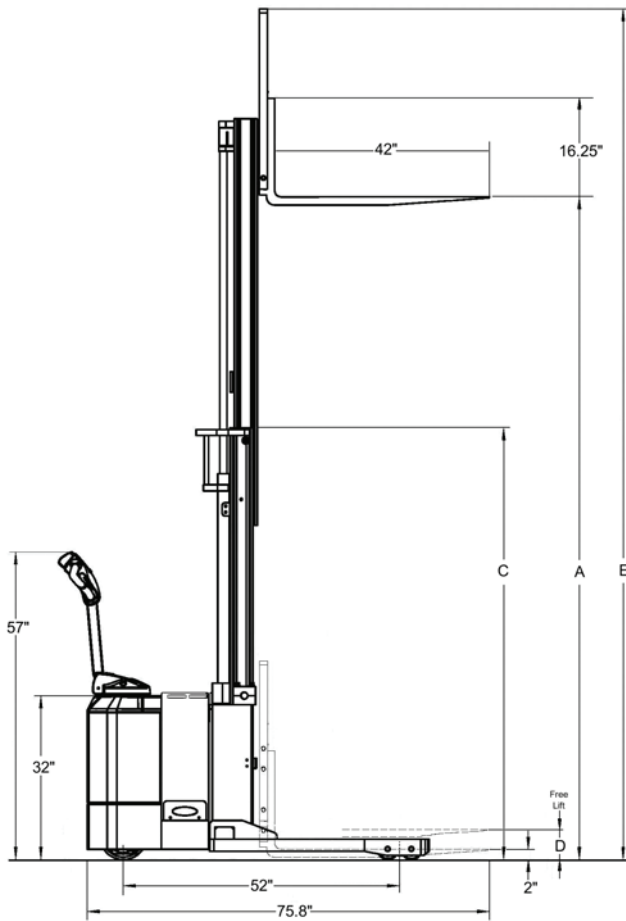

* For metric conversion multiply inches by 25.4.



Right Angle Stacking Aisle Dimensions

Load Length	Load Width			
	36"	40"	42"	48"
36"	69"	69"	71"	71"
42"	69"	69"	71"	71"
48"	80"	83"	85"	87"

*For metric conversion multiply inches by 25.4.

- Aisle dimensions listed have zero clearance
- Add 3" for triple stage mast
- Add 12" for ease of use

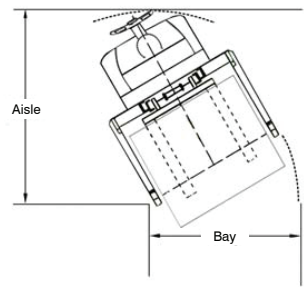

Note: Aisle dimensions listed above assume the bay width to be straddle OD plus 2" (1" on each either side of straddle leg). Straddle OD is the load width plus 10".

* For metric conversion multiply inches by 25.4.

Model #	Mast	Lift Height	Col Height	Free Lift	Ext Height w/LBR	Adjustable Straddle Leg 4" Increments		Weight Chassis Only
		A	C	D	E	ID	OD	

3,000 Capacity @ 24" Load Center ITA Class II Fork Carriage

PDS30-104	Telescopic	104	71	6	142	38 to 50	46 to 58	2042
PDS30-126	Telescopic	126	83	6	165	38 to 50	46 to 58	2172
PDS30-142	Telescopic	142	91	6	178	38 to 50	46 to 58	2239
PDS30-157	** TriMast	157	71	50	193	42 to 50	50 to 58	2444
*PDS30-177	** TriMast	177	79	58	213	42 to 50	50 to 58	2539

*Derates 1000 lbs above 162" **TriMast minimum inside dimension (ID) 42" - outside dimension (OD) = inside dimension + 8"
*For metric conversion multiply inches by 25.4.



85 Heart Lake Road South
Brampton, Ontario, Canada L6W 3K2
Phone: 905-457-3900 • Fax: 905-457-2313
www.BlueGiant.com

AUTHORIZED DISTRIBUTOR

BLUE GIANT MATERIAL HANDLING DIVISION

BLUE GIANT offers a full line of Loading Dock Equipment including Dock Levelers, Vehicle Restraints, Dock Seals and Shelters and Material Handling Solutions. Concurrent with our continuing product improvement program, specifications are subject to change without notice. Please contact BLUE GIANT for latest information. Some features illustrated may be optional in certain market areas.