

OWNER'S MANUAL

PNEUMATIC IN-PLANT LIFT TABLE

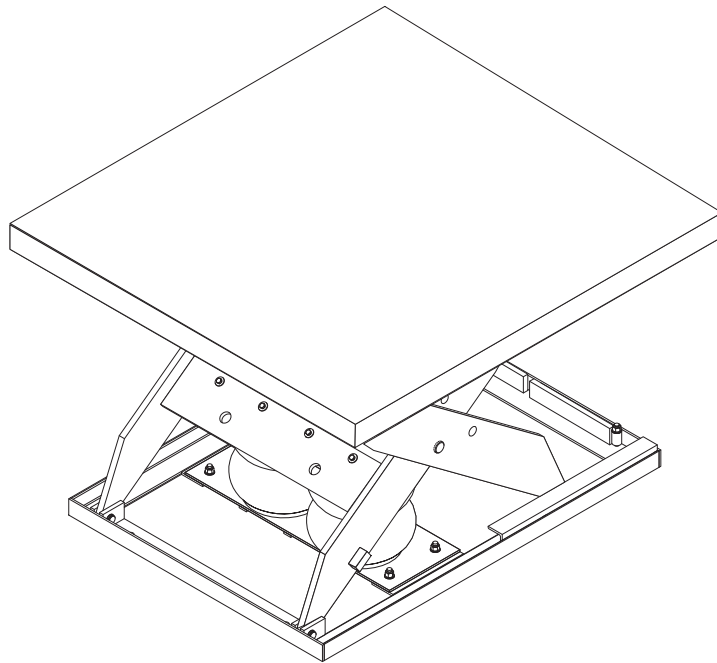

ACTUAL PRODUCT MAY NOT APPEAR EXACTLY AS SHOWN

WARNING

Do not operate or service this product unless you have read and fully understand the entire contents of this manual. Failure to do so may result in bodily injury or death.

BLUE GIANT[®]

Table of Contents

1.0	ABOUT THE LIFT TABLE	5
1.1	OWNER'S PURCHASE RECORD	5
2.0	INTRODUCTION	6
2.1	WARRANTY INFORMATION	6
2.2	EXCLUSION OF LIABILITY	6
2.3	MANUFACTURER'S NOTE	7
2.4	OWNER'S RESPONSIBILITY	7
3.0	SAFETY MESSAGE COLOR IDENTIFICATION	9
3.1	OPERATIONAL SAFETY WARNINGS	9
4.0	LOCKOUT / TAGOUT PROCEDURE AND RULES	11
5.0	CONTROL STATION OPERATION	12
5.1	PUSH BUTTON CONTROLS	12
6.0	LIFT TABLE MAINTENANCE STRUTS	13
6.1	ENGAGING THE LIFT TABLE MAINTENANCE STRUTS	13
6.2	DISENGAGING THE LIFT TABLE MAINTENANCE STRUTS	14
7.0	MAINTENANCE	15
7.1	PLANNED MAINTENANCE PROGRAM (PMP)	15
7.2	OPERATOR DAILY INSPECTION	15
7.3	ROUTINE SERVICING AND MAINTENANCE	15
7.4	PLANNED MAINTENANCE PROGRAM INTERVALS	15
7.5	MAINTENANCE SEQUENCE	15
7.6	DAILY MAINTENANCE PROCEDURES (DMP) CHECKLIST	17
8.0	OPERATING INSTRUCTIONS	19
8.1	LOAD TRANSFER	19
8.2	RAISING OR LOWERING LIFT TABLE	19
9.0	RECOMMENDED PARTS	20
9.1	STANDARD OPERATIONAL COMPONENTS	20
9.2	OPTIONAL SUPPORT COMPONENTS	21
9.3	LIFT TABLE ROLLING END	23
9.4	LIFT TABLE LOWER FRAME AND ROLLING END DETAIL	24
9.5	LIFT TABLE UPPER FRAME AND FIXED END DETAIL	24
9.6	ACCORDION SAFETY SKIRT	25
10.0	DECAL IDENTIFICATION AND LOCATION	26
11.0	EQUIPMENT COMPONENT ILLUSTRATIONS	28
11.1	COMPONENTS AS SHIPPED CHECKLIST	28
11.2	LIFT TABLE MECHANICAL ASSEMBLY	29
12.0	TROUBLESHOOTING	30
13.0	OPTIONAL EQUIPMENT	31
13.1	SAFETY FEATURES	31
14.0	PNEUMATIC SCHEMATICS	32

1.0 ABOUT THE LIFT TABLE

The Blue Giant Pneumatic In-plant Lift Table is a high performance system. The Pneumatic In-plant Series provides load transfer/manipulation options for production facilities. The deck is constructed with beams welded at dynamic impact points to provide a sturdy deck support. Pneumatic components increase operating efficiency, operator safety, and reduce maintenance requirements. The lift functions have independent Pneumatic lifts via facility-integratable controls and hand-held controls.

1.1 OWNER'S PURCHASE RECORD

Please record information for future inquiries and to validate warranty. See "2.1 WARRANTY INFORMATION" on page 6.

Dealer:	Date in Service:
	Number of Units:
Serial Number:	Location #:
Serial Number:	Location #:
Serial Number:	Location #:
Serial Number:	Location #:
Serial Number:	Location #:
Serial Number:	Location #:
Serial Number:	Location #:
Serial Number:	Location #:
Serial Number:	Location #:

The manufacturer offers a full line of in-plant lift tables, tilters, turn tables, safety equipment, accessories, ergonomic equipment, and industrial trucks. Concurrent with a continuing product improvement program, specifications are subject to change without notice (See "2.2 EXCLUSION OF LIABILITY" on page 6). Please contact the your Blue Giant Dealer for latest information. Some features illustrated may be optional in certain market areas.

NOTICE
See "10.0 DECAL IDENTIFICATION AND LOCATION" on page 31 for serial number location.

2.0 INTRODUCTION

The following is a quick reference to important procedures that must be followed while using the Pneumatic In-plant Lift Table System. It is not intended to cover, or suggest that it does cover, all procedures necessary to ensure safe operation. All owners and operators should be aware of and abide by all workplace safety regulations applicable to the inspection and operation of the Lift Table. These laws and regulations include but are not limited to:

- The Occupational Safety and Health Act
- Canada Occupational Health and Safety Regulations
- Occupational Safety and Health Acts for Individual States (USA), Provinces, or Territories.
- ANSI standard MH29.1 and MH29.2

For additional information on these regulations as well as industry standards that may apply to this product, please contact:

American National Standards Institute (ANSI)

1430 Broadway

New York, NY 10018

Telephone: 212.642.4900

www.ansi.org



Lift Manufacturers Product Group (LIFT)

A Product Section of Material Handling Industry of America

A Division of Material Handling Industry

8720 Red Oak Blvd, Suite 201

Charlotte, NC, 28217-3992

Telephone: 704.676.1190

www.mhi.org/lift



2.1 WARRANTY INFORMATION

Thank you for purchasing Blue Giant products. We appreciate your business, and are confident that our product will serve you for many years to come. In the event that you experience a problem with our product, our Customer Support Team is here to support the Blue Giant Product(s) that you have purchased.

To validate warranty on recently purchased equipment, please complete and submit your information with our on-line Warranty Registration at www.BlueGiant.com.

For more information about Blue Giant Warranty Support, please contact your Blue Giant Dealer. You may also visit www.BlueGiant.com or phone 1.800.872.2583.

NOTE: All products must be registered to qualify for warranty.

DEALER INFORMATION

Name:

Contact:

Telephone:

2.2 EXCLUSION OF LIABILITY

To the maximum extent permitted by applicable law, the manufacturer assumes no liability for damage or injury to persons or property that occur as a result of use of the Pneumatic In-plant Lift Table equipment. Furthermore, to the maximum extent permitted by applicable law, the manufacturer does not assume any liability for lost profits, operating downtimes, consequential, indirect, incidental, special, exemplary, punitive or enhanced damages, or similar losses, whether incurred by owner, authorized users and other third parties. By use of the Pneumatic In-plant Lift Table equipment, owner assumes all risk of liability for damage or injury to persons or property that occur as a result of use of the Pneumatic In-plant Lift Table equipment, including, with respect to owner, authorized users and other third parties.

The manufacturer reserves the right to make changes at any time to the modules, components, and accessories, concurrent with its continuing product improvements and development program. Specifications, operating instructions, and illustrations included in this

manual are subject to change without advance notice. As the Pneumatic In-plant Lift Table equipment is a highly customizable product, please contact the manufacturer by telephone at 1.800.872.2583 for the latest information.

2.3 MANUFACTURER'S NOTE

The Pneumatic In-plant Lift Table equipment has been carefully inspected and tested at the manufacturer's plant prior to shipment, but **MUST be checked** upon receipt for transport damage. Any observed transport damage is to be listed on the signed copy of the freight document. There are many configurations or custom designs whose specifications may not be fully reflected in this manual. Contact your Blue Giant Dealer to obtain the General Arrangement drawing for application specific designs.

Notify the freight forwarder and the dealer of any damage WITHIN 24 HOURS.

2.4 OWNER'S RESPONSIBILITY

The Pneumatic In-plant Lift Table equipment needs to be maintained and inspected by the owner to verify its safe condition for operation.

1. The owner should recognize the inherent danger of the interface between the Pneumatic In-plant Lift Table equipment and other components. The owner should, therefore, train and instruct operators in the safe use of the Pneumatic In-plant Lift Table equipment and accessories in accordance with the manufacturer's recommendations.
2. The owner should thoroughly familiarize themselves with the following procedures and specifications as referenced in this manual, and request immediate replacement of all manufacturer-supplied documents that are missing, damaged, or otherwise illegible. Owners shall apply sound principles of safety, training, inspection, maintenance, and expected operating environment toward their Pneumatic In-plant Lift Table equipment usage and maintenance requirements.

- Commissioning instructions
- Operating instructions
- Daily maintenance procedures checklist
- Inspections procedures
- Recommended spare parts lists

Upon receipt of any newly purchased Pneumatic In-plant Lift Table equipment, the owner shall verify the presence of owner's manuals, operating placards, and any other documentation necessary for training dock personnel how to use the equipment safely and effectively.

3. All Blue Giant Pneumatic In-plant Lift Table equipment shall undergo regularly scheduled planned maintenance. Maintenance requirements will vary according to usage frequency and application, so the owner shall contact with their authorized Blue Giant distributor for schedule recommendation. Written records of the performance of these procedures shall be kept as per warranty requirements and per local state or provincial requirements. Please see "7.0 MAINTENANCE" on page 18.
4. Pneumatic In-plant Lift Table equipment that is structurally damaged, experiencing performance irregularities, or has been potentially compromised shall be removed from service until a trained and authorized manufacturer's representative can conduct an inspection and perform any necessary repairs.
5. As with any piece of machinery, Pneumatic In-plant Lift Table equipment requires routine maintenance, lubrication, and adjustments. Recommended procedures are itemized in the Planned Maintenance Program (PMP) checklist included in installation and technical manuals. It is recommended that for anything other than the basic maintenance procedures outlined in this manual, please contact your Blue Giant Dealer.
6. The owner shall ensure that all nameplates and safety labels are in place and legible, and that the appropriate manuals are provided to authorized users. Replacement nameplates, safety labels, and manuals are available through the Blue Giant Aftermarket Department. See "12.0 DECAL IDENTIFICATION AND LOCATION" on page 45 in this manual for more information.
7. Unless specifically agreed to in writing by Blue Giant Equipment Corporation at the time of order (and prior to manufacture), all Blue Giant Pneumatic In-plant Lift Table equipment is sold as a complete offering and must not be altered or added to in any manner (which includes configuration and function) without written permission from an authorized manufacturer's representative. These changes shall also satisfy all safety recommendations of the original equipment manufacturer for the particular application of the Pneumatic In-plant Lift Table equipment.

8. If, at the request of the owner, Blue Giant does not supply all or some of the Pneumatic In-plant Lift Table equipment systems and/or control panel components, the owner shall assume responsibility for any and all operational and safety issues associated with the resulting configuration.
9. The owner must adhere to the load classification information provided on the product nameplate. Failure to do so will void product warranty and can result in serious injury, including death.
10. Operational placard must be visible from equipment location and permanently attached to a wall or structure.
11. The owner shall ensure that inspections are performed to the lifting device as prescribed by law or regulation.

3.0 SAFETY MESSAGE COLOR IDENTIFICATION

This manual includes color-coded safety messages that clarify instructions and specify areas where potential hazard exists. To reduce the possibility of equipment damage and serious injury or death, please follow the instructions and understand the warnings contained in the messages. If warning decals become damaged or missing, replace them immediately. Avoid accidents by recognizing dangerous procedures or situations before they occur.

 DANGER
Serious injury or death will likely occur if the instructions are not followed.

 WARNING
Serious injury or death may occur if the instructions are not followed.

 CAUTION
Instructions marked caution concern safe operating procedure. Failure to comply may result in personal injury.

NOTICE
Procedures marked notice must be followed in order to reduce damage to machinery.

3.1 OPERATIONAL SAFETY WARNINGS

These are safety warnings that may be part of a procedure or hardware warning decal.

 DANGER
<ul style="list-style-type: none"> • BEFORE BEGINNING ANY SERVICE PROCEDURES: • – Disconnect the Pneumatic energy source and follow all lockout / tagout procedures, as per OSHA requirements. Refer to Pneumatic schematics. • Never operate a broken or damaged Pneumatic In-plant Lift Table. Repair immediately by a qualified service technician. • All loads must be centered and secured from rolling off the platform. Loose or unbalanced loads are dangerous. • While transferring load, be aware of potential fall risks from table edges.

 WARNING
<ul style="list-style-type: none"> • Do not use fingers or hands to remove foreign materials. • Deck may drop unexpectedly, keep people and objects clear of the area immediately under or near the lift table. • Post safety warnings and barricade working area around the Pneumatic In-plant Lift Table and at ground level to reduce unauthorized use of the lift table during maintenance/service. • Pneumatic In-plant Lift Table operator must be present during all steps of this procedure and keep an unobstructed view of Pneumatic In-plant Lift Table to ensure safe operation. Never leave the Pneumatic In-plant Lift Table unattended in the raised position. • Never leave loads sitting on the Pneumatic In-plant Lift Table. • Do not operate the Pneumatic In-plant Lift Table beyond its rated capacity. Before load transfers, verify the load does not exceed the single axle rolling load maximum rating as found on nameplate of the Pneumatic In-plant Lift Table. • Never attempt to lift or hold the table by hand unless instructed by this manual and using caution. Serious personal injury could occur.

 **CAUTION**

- Only trained personnel should operate or service this equipment.
- Always park the Pneumatic In-plant Lift Table equipment after use.
- Conduct routine inspections and maintenance. Failure to do so could cause equipment damage and or personal injury.
- Always contact your Blue Giant Dealer immediately if a malfunction occurs.

NOTICE

- Do not ground welding equipment to any Pneumatic components.
- Do not attach welder as ground to lift platform when welding on base frame assembly. Attach welder ground to base frame assembly only.
- Do not allow the drill to go too deeply when drilling holes in the control box. Damage to the control systems may occur.
- Never use air to blow debris from control box. Use a vacuum to remove debris from control box.
- Do not connect green ground lead into control box until all welding has been completed.
- Always keep the work area clean and free of litter.
- Always clean all side openings of dirt and debris.
- Always clean up dry and liquid spills immediately after they occur.
- Always maintain proper lighting in the work area.
- If a procedure is not clearly defined in this manual, contact your Blue Giant Dealer.

4.0 LOCKOUT / TAGOUT PROCEDURE AND RULES

In accordance with the rules and regulations of the Occupational Safety and Health Administration (OSHA) and/or local jurisdiction, all affected employees must be notified that the machine or equipment will be shut down and locked out to perform repair or maintenance work.

The work area must be checked to verify that all personnel have been removed or safely repositioned.

The machine or equipment Pneumatic energy supply shall be locked in the **OFF** position or disconnected from the Pneumatic energy source.

Blue Giant strongly recommends that only OSHA-approved and/or local jurisdiction lockout devices and procedures be utilized.

The energy isolating device must bear a prominent warning tag indicating that work is being done on the equipment and the name of the authorized employee responsible for the lockout.

It is mandatory that tagout notices shall **NOT** be susceptible to deterioration or illegibility due to weather conditions, exposure to chemicals and/or moisture.

WARNING

- Always lockout and tagout any Pneumatic energy source before performing any work on any Pneumatic devices or Pneumatic controls according to OSHA regulations and approved local Pneumatic codes. Refer to Pneumatic schematics.

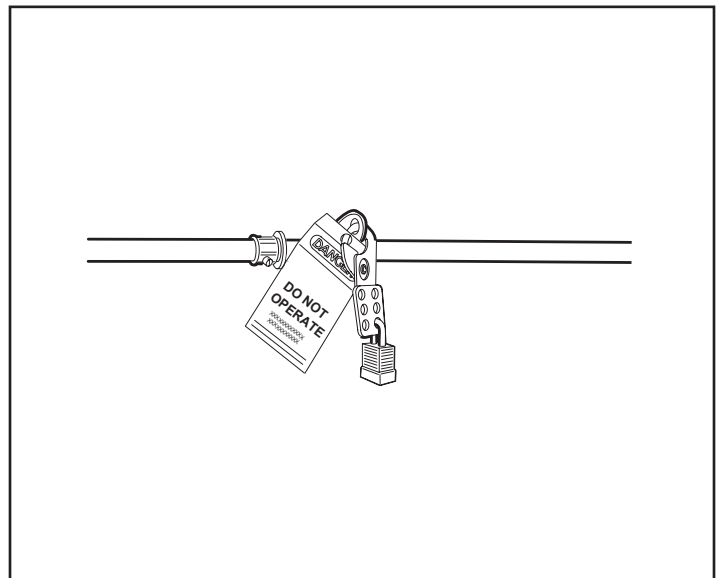

An example of lockout / tagout. Verify and comply with local codes/ regulatory requirements.

5.0 CONTROL STATION OPERATION

As the Pneumatic In-plant Lift Table is part of an assembly line environment, the Pneumatic schematics and site documentation will give the correct control setup and use.

5.1 PUSH BUTTON CONTROLS

DANGER

- While lifter is moving, keep people and objects clear of areas under the platform and in the immediate lift area.
- Fully read and understand the lift operation. Practice safe load transfer methods. If you do NOT understand the complete lift operating procedure and safe load transfer methods, refer to the Owner/Operator regarding local regulatory/jurisdictional and facility requirements.

WARNING

- Pneumatic In-plant Lift Table operator(s) must be present during all steps of this procedure.
- Pneumatic In-plant Lift Table operator(s) must keep an unobstructed view of Lift Table, any operation light/horn/bell, and other operators to ensure safe operation.
- Do not exceed (rated lifting) capacity or load classification of lift as listed on the manufacturer/product nameplate. Capacity includes: forklift/manual equipment, pallet(s), material(s)/goods, operator, and any other objects on the deck/platform. See “2.4 OWNER'S RESPONSIBILITY” on page 7. For nameplate location, see “10.0 DECAL IDENTIFICATION AND LOCATION” on page 31.
- To avoid bodily injury, stand clear of Lift Table while it is moving.

Depending on the Pneumatic In-plant installation, the Lift Table may have hand or pedal controls available. Consult the specific installation Pneumatic schematic for these options, if present.

6.0 LIFT TABLE MAINTENANCE STRUTS

This section describes the different functions of the Maintenance Struts. These procedures require at least temporary Pneumatic power to raise and lower the Lift Table.

6.1 ENGAGING THE LIFT TABLE MAINTENANCE STRUTS

The Maintenance Strut is engaged to perform cleaning or visual inspection under the Lift Table.

DANGER

- Failure to properly secure the Lift Table deck prior to working underneath it may result in bodily injury, or death.
- Engage the Maintenance Struts before visual inspecting or cleaning under the deck. If the struts cannot be successfully engaged, contact your Blue Giant Dealer.

WARNING

- Post safety warnings and barricade work area at ground level. Notify all affected personnel that work is being performed on the unit and follow proper lock-out procedure. Verify that the energy source to the unit has been completely cut off and cannot be turned back on accidentally, as per OSHA requirement.
- Head protection and other applicable PPE is recommended when working under or around the raised deck.
- Use Maintenance Struts when working under the Lift Table. (i.e. more than cleaning or visually inspecting)

CAUTION

- It is recommended that a retrieval tool be used when retrieving or replacing the Maintenance Struts from the stored positions.
- It is recommended that this procedure be performed with assistance.

1. Press and hold the **DOWN** button to lower the Lift Table to the lowest height position.
2. Clear any load or debris on the Lift Table's deck.
3. When the area around the Lift Table is clear of personnel, equipment, and materials, press and hold the **UP** push button to raise the Lift Table to a point where it is safe to deploy the Maintenance Struts then release the push button.
4. Examine the Lift Table Maintenance Struts for damage or if it is missing. Contact your Blue Giant Dealer for service or repair, as required.
5. Flip or move the Lift Table Maintenance Struts into the locked position. Only reach in far enough with a body part to move each Maintenance Strut.

NOTE: Actual product may not appear exactly as shown.

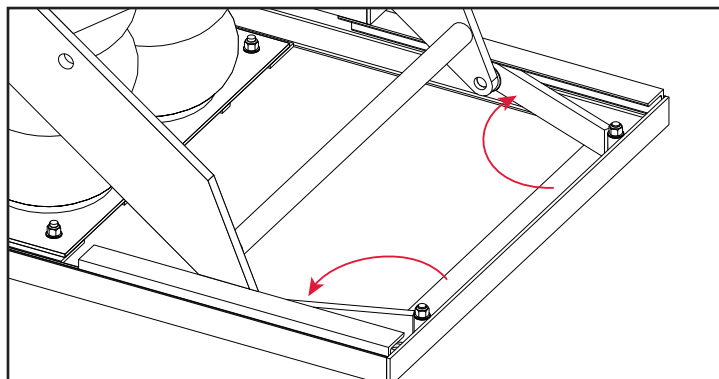

6. Press and hold the **DOWN** button to lower the Lift Table until the Maintenance Struts are fully braced against the lower frame of the Lift Table.
7. When the Maintenance Struts are fully braced and holding the Lift Table in position, an authorized person shall lock out and tag out the Pneumatic connections to the Pneumatic Lift Table.
8. If safe to do so, use an extension tool to clear any debris or material from under the Lift Table.
9. Inspect the Lift Table and minimize any time spent under the Lift Table.

6.2 DISENGAGING THE LIFT TABLE MAINTENANCE STRUTS

The Maintenance Strut is disengaged after a cleaning or visual inspection is completed under the Lift Table.

DANGER

- Failure to properly secure the Lift Table deck prior to working underneath it may result in bodily injury, or death.
- Engage the Maintenance Struts before visual inspecting or cleaning under the deck. If the struts cannot be successfully engaged, contact your Blue Giant Dealer.

WARNING

- Post safety warnings and barricade work area at ground level. Notify all affected personnel that work is being performed on the unit and follow proper lock-out procedure. Verify that the Pneumatic energy source to the unit has been completely cut off and cannot be turned back on accidentally, as per OSHA requirement.
- Head protection and other applicable PPE is recommended when working under or around the raised deck.
- Use Maintenance Struts when working under the Lift Table. (i.e. more than cleaning or visually inspecting)
- Do not stand in the pathway of the Lift Table during the disengagement process in case the Lift Table falls unexpectedly.

CAUTION

- It is recommended that a retrieval tool be used when retrieving or replacing the Maintenance Struts from the stored positions.
- It is recommended that this procedure be performed with assistance.

1. Examine the Maintenance Struts for damage or if any are missing. Contact your Blue Giant Dealer for service or repair, as required.
2. When all work is completed and the area around the Lift Table is cleared, an authorized person shall inform all affected personnel before removing the lock out and tag out from the Pneumatic connections to the Pneumatic Lift Table.
3. Press and hold the **UP** button to gently raise the Lift Table off of the Maintenance Struts.
4. Flip the Maintenance Struts to the stored position. Use an extension tool (i.e. broom handle or wood) to move the Maintenance Strut. As much as possible, never reach in with a body part to move the Maintenance Strut.

NOTE: Actual product may not appear exactly as shown.

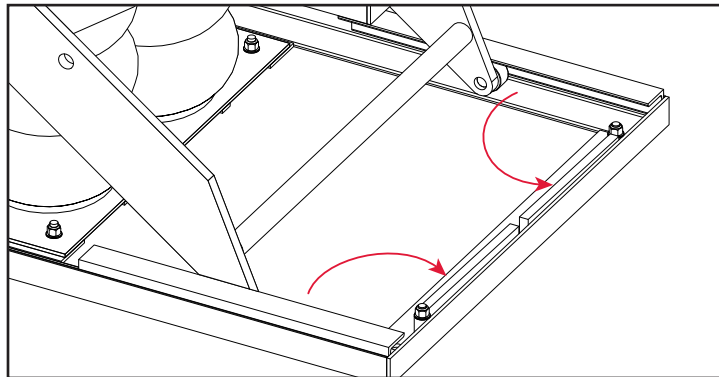

5. Press and hold the **DOWN** button to lower the Lift Table to ground or lowest height position then release the button.

7.0 MAINTENANCE

Develop a planned or scheduled maintenance plan to keep the lift table in good operating order.

DANGER

- Failure to properly secure the lift table deck prior to working underneath it may result in bodily injury, or death.
- Engage the Maintenance Struts before visual inspecting or cleaning under the deck. If the struts cannot be successfully engaged, contact your Blue Giant Dealer.

WARNING

- Do not attempt to install, make repairs, or adjustments. Only a trained and authorized service technician should perform the installation process, make repairs, or make adjustments. Contact your Blue Giant Dealer for assistance.
- Do not service this equipment until you have read and understood all of the safety information and instructions contained herein.
- Failure to adhere to recommended safety practices in this manual and on the lift table equipment warning labels could result in death or serious injury.
- Do not conduct maintenance or repairs until adequate barriers have been placed to keep warehouse and vehicle traffic away from the work area.
- Before doing any Pneumatic work, verify that the Pneumatic energy source is disconnected and properly tagged or locked out.
- When conducting maintenance, use only Blue Giant approved lubricants. Improper lubrication or adjustments may cause operational problems.

7.1 PLANNED MAINTENANCE PROGRAM (PMP)

In addition to the Daily Maintenance Procedures (DMP), the manufacturer recommends (and local government regulations may require) that a Planned Maintenance Program (PMP) and safety inspection program be performed by a trained and authorized service technician on a regular basis to ensure the equipment is in safe operating condition. The PMP will provide an opportunity to make a thorough inspection of the safety and operating condition of the lift table. Necessary adjustments and repairs can be done during the PMP, which will increase the life of components and reduce unscheduled downtime.

Recommended procedures for a periodic planned maintenance program that covers inspections, operational checks, cleaning, lubrication, and minor adjustments are outlined in the Owner's Manual for this product. Contact your Blue Giant Dealer regarding for assistance with a planned maintenance program by offering trained service personnel with expertise in lift table maintenance requirements.

7.2 OPERATOR DAILY INSPECTION

The lift table shall always be examined by the operator **PRIOR TO ANY USE** to verify that it is safe to operate.

The manufacturer recommends scanning to storage or making multiple photocopies of the DMP Checklist. The operator should fill out this form to keep a daily record of operation and maintenance issues. See "7.6 DAILY MAINTENANCE PROCEDURES (DMP) CHECKLIST" on page 16.

7.3 ROUTINE SERVICING AND MAINTENANCE

Regular maintenance and care of the lift table is very important for operator safety, operation efficiency, and cost. A faulty lift table is a potential source of danger to the operator, and to other personnel working near it. As with all quality equipment, keep the lift table in good operating condition by following the recommended schedule of maintenance. Failure to properly maintain or operate the lift table within its rated load classification can void the manufacturer warranty.

7.4 PLANNED MAINTENANCE PROGRAM INTERVALS

Arrange for a qualified lift table repair technician to perform regularly scheduled planned maintenance on your lift table every three months for single shift operations or monthly for multi-shift operations. Call your authorized manufacturer / dealer for further details.

7.5 MAINTENANCE SEQUENCE

Follow this procedure for maintenance of the lift table.

1. Cleaning, including under lift table and/or in pit area.

2. Visual inspection of all components.
3. Lubrication, as required (by a trained service technician only).
4. Test operate all functions.
5. Adjustments, if required (by a trained service technician only).
6. Record inspection details and findings for owners' files.



DEALER: _____

PLANNED MAINTENANCE PROGRAM - PMP CHECKLIST

Lift Table

Customer:		SWO#
Location:		Date:
Contact:	Telephone:	Inspected By:
Signature:	Model / Serial #:	

WARNING

NOTE TO TECHNICIAN: ALL ITEMS ON LIST MUST BE VERIFIED AND CHECKED. ITEMS WITH AN * REQUIRE LUBRICATION.	Position #	Position #	Position #	Position #	Position #
	✓	✓	✓	✓	✓
	Barricade area				
Disconnect energy source per OSHA requirements					
Clean debris from in and around lift table					

Mark the following with one of the following: ✓ = GOOD ✗ = COMMENTS / REQUIRES REPAIR	Position #		Position #		Position #		Position #		Position #	
	✓	✗	✓	✗	✓	✗	✓	✗	✓	✗
	Mount area									
Wire harness / cables										
Pneumatic hose assembly										
Airbags(s)										
Structural damage										
Pneumatic connectors										
Lowering speed flow control (If present)										
Leg rollers *										
Scissor pin bushings *										
Lift Maintenance Strut(s) *										
Check that operational placard present and legible										
Complete operating cycle by checking lights for proper sequence, both inside and outside if so equipped										

Unit Certified for Maximum Lift Capacity	Position #	Comments (for items marked with an ✗):

8.0 OPERATING INSTRUCTIONS

Depending on the Pneumatic In-plant installation, the lift table may have controls available. Consult the specific installation pneumatic schematic for these options, if present.

8.1 LOAD TRANSFER

When transferring loads onto and off of a lift table, the cargo weight distribution should **NEVER** exceed the maximum value on the weight rating decal. The lift table weight rating decal lists the maximum load values for the lift table.

8.2 RAISING OR LOWERING LIFT TABLE

The following Danger and Warning list apply to any lift table.

DANGER

- While lift table is moving, keep people and objects clear of areas under the platform and in the immediate lift table area.
- Fully read and understand the lift table operation. Practice safe load transfer methods. If you do NOT understand the complete lift table operating procedure and safe load transfer methods, refer to the Owner/Operator regarding local regulatory/jurisdictional and facility requirements.
- While monitoring the lift table, be aware of potential fall risks from deck edges.

WARNING

- The lift table operator(s) must be present during all steps of this procedure.
- The lift table operator(s) must keep an unobstructed view of lift table, any operation light/horn/bell, and other operators to ensure safe operation.
- Do not exceed (rated lift table) capacity or load classification of lift table as listed on the manufacturer/product nameplate. Capacity includes: any object(s) on the deck/platform. See "2.4 OWNER'S RESPONSIBILITY" on page 7. For nameplate location, see "10.0 DECAL IDENTIFICATION AND LOCATION" on page 31.
- To avoid bodily injury, stand clear of lift table while it is moving.

Read and understand these instructions and safety rules before operating lift table:

- Before using lift table, inspect it for proper operation and condition. If any unsafe condition exists, remove unit from service until repairs are made.
- Before using lift table, inspect any/all safety devices to verify that they are in place and functioning properly.
- Prior to placing a load on lift table, read and understand the rated capacity of the unit, as labeled on the nameplate attached to the side of the deck assembly. The rated lift table capacity is the maximum uniformly distributed load permitted for the unit.

9.0 RECOMMENDED PARTS

9.1 STANDARD OPERATIONAL COMPONENTS

ITEM	QTY	PART NO.	DESCRIPTION
3	2	071-0226	AIR SPRING,3 FOLD,11 7/8 OD,4 1/2 TO 18
4	4	071-0106	WHEEL PIN,LOWER,7/8ODX1-3/4 L
5	12	071-0019	BUSHING,1.252X1.502X0.50
6	4	071-0104	STEEL,WHEEL,2"OD,1"HOLE
7	12	071-0072	RETAINING RING,EXTERNAL,7/8"
8	2	071-0103	STEEL,WHEEL SPACER,1 1/2 OD,7/8 ID
9	4	071-0102	LEG BLOCK PIN, 0.87ODX2-3/8L
10	2	090-848	STEEL TUBE 2"OD X 1/4"WALL X2 3/4"L
11	2	2022095	LFT CNTR PIN,1 1/4"DIA X2 1/2"L
12	2	090-835	STEEL, BAR, FLAT, REC, 2"X3/4"
13	2*	2030534	1/4" CLEAR PLASTIC TUBING*
14	1*	2023640	1/4" CLEAR PLASTIC TUBING*
15	2*	2023635	FTNG;ELBOW;90DEG; 3/8JIC
16	1*	2023637	MALE TEE, BRASS, 1/4IN, MNPT
17	1	040-054	VALVE,AIR RELIEF VALVE,135PSI,NPTM,1/4

* - Contact Blue Giant customer support

9.2 OPTIONAL SUPPORT COMPONENTS

ITEM	QTY	PART NO.	DESCRIPTION
3	2	071-0226	AIR SPRING,3 FOLD,11 7/8 OD,4 1/2 TO 18
4	4	071-0106	WHEEL PIN,LOWER,7/8ODX1-3/4 L
5	12	071-0019	BUSHING,1.252X1.502X0.50
6	4	071-0104	STEEL,WHEEL,2"OD,1"HOLE
7	12	071-0072	RETAINING RING,EXTERNAL,7/8"
8	2	071-0103	STEEL,WHEEL SPACER,1 1/2 OD,7/8 ID
9	4	071-0102	LEG BLOCK PIN, 0.87ODX2-3/8L
10	2	090-848	STEEL TUBE 2"OD X 1/4"WALL X2 3/4"L
11	2	2022095	LFT CNTR PIN,1 1/4"DIA X2 1/2"L
12	2	090-835	STEEL, BAR, FLAT, REC, 2"X3/4"

* Contact Blue Giant customer support - Quantity / Length may vary due to configuration or airbag quantity.

LIFT TABLE HOSES			
ITEM	QTY	PART NO.	DESCRIPTION
13	2*	2030534	1/4" CLEAR PLASTIC TUBING*
14	1*	2023640	1/4" CLEAR PLASTIC TUBING*
15	2*	2023635	FTNG;ELBOW;90DEG; 3/8JIC
16	1*	2023637	MALE TEE, BRASS, 1/4IN, MNPT
17	1	040-054	VALVE,AIR RELIEF VALVE,135PSI,NPTM,1/4

* Contact Blue Giant customer support - Quantity / Length may vary due to configuration or airbag quantity.

NOTE: Configuration may vary due to controls or number of airbags. Refer to site diagram.

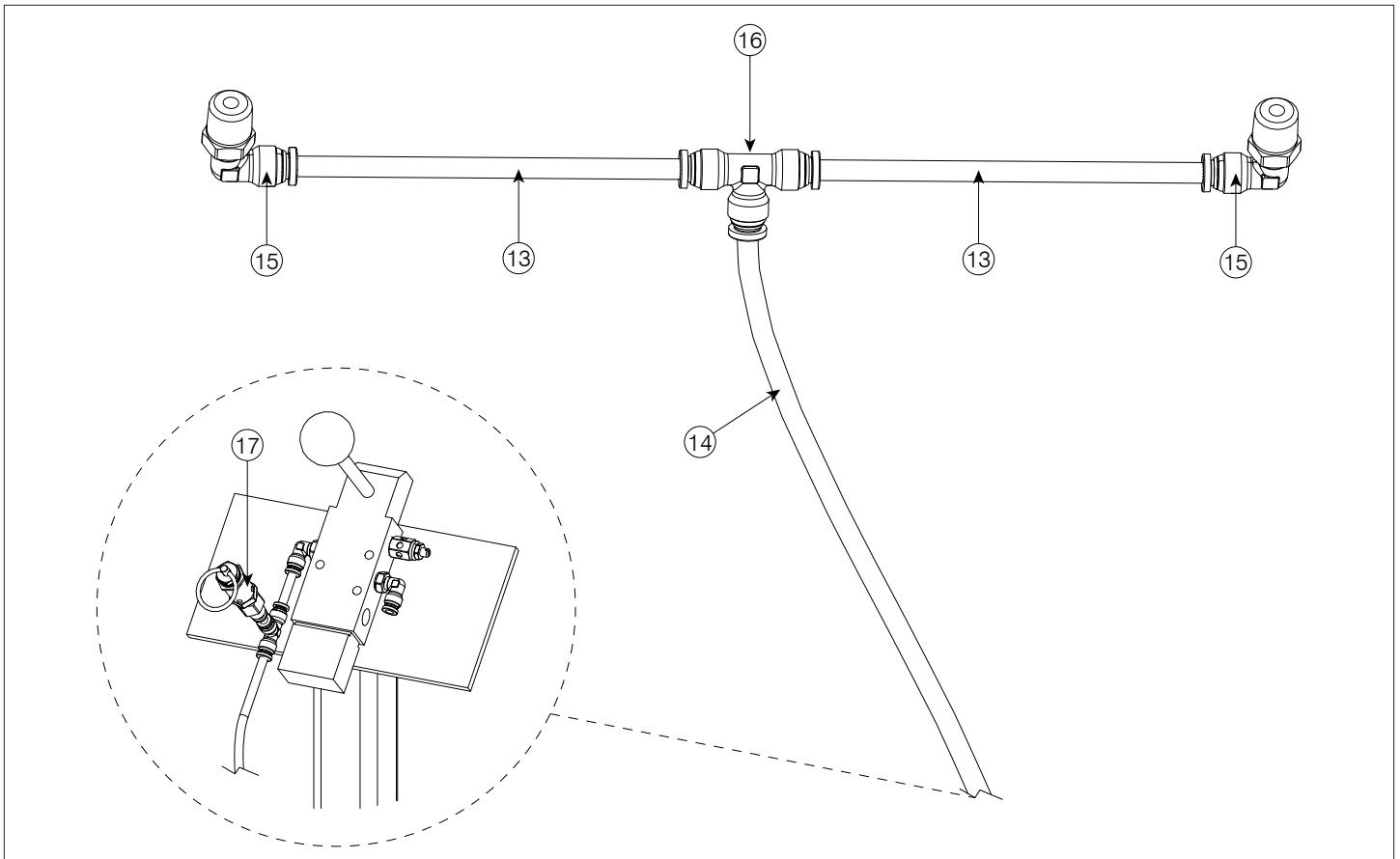

9.3 LIFT TABLE ROLLING END

This diagram displays the Lift Table and the field replaceable parts.

NOTE: Actual product may not appear exactly as shown.

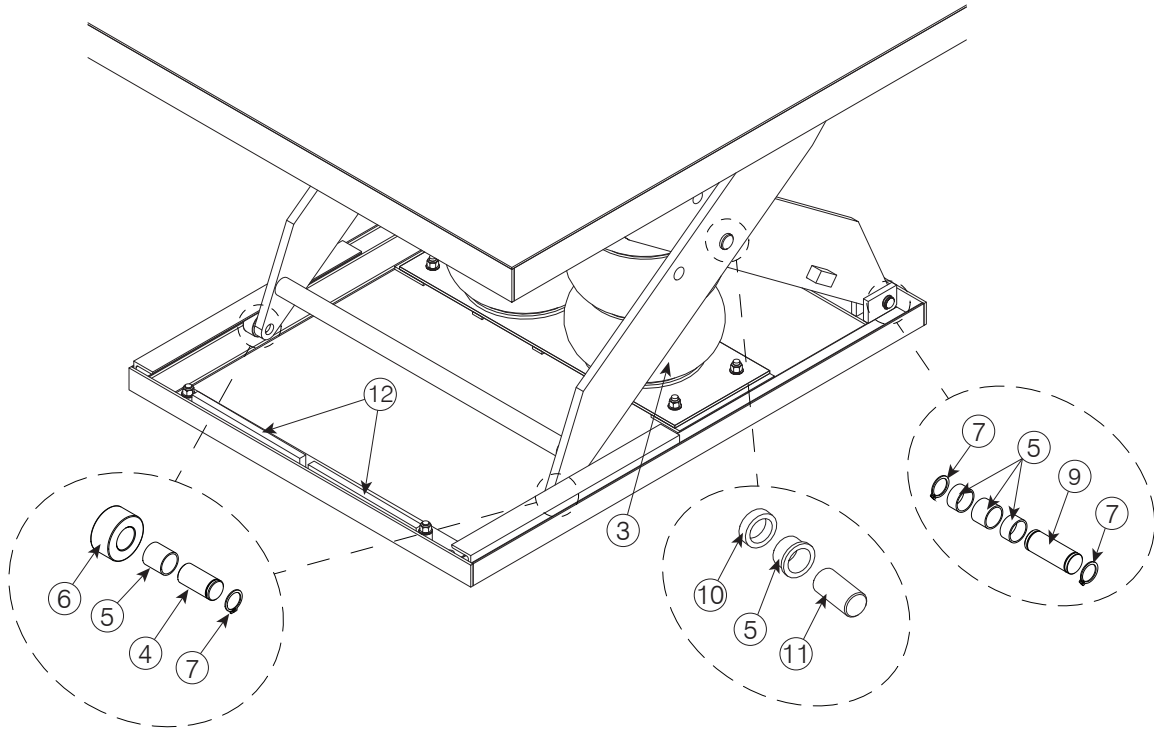

9.4 LIFT TABLE LOWER FRAME AND ROLLING END DETAIL

This diagram displays the rolling wear portions, lift airbag detail, and leveling components.

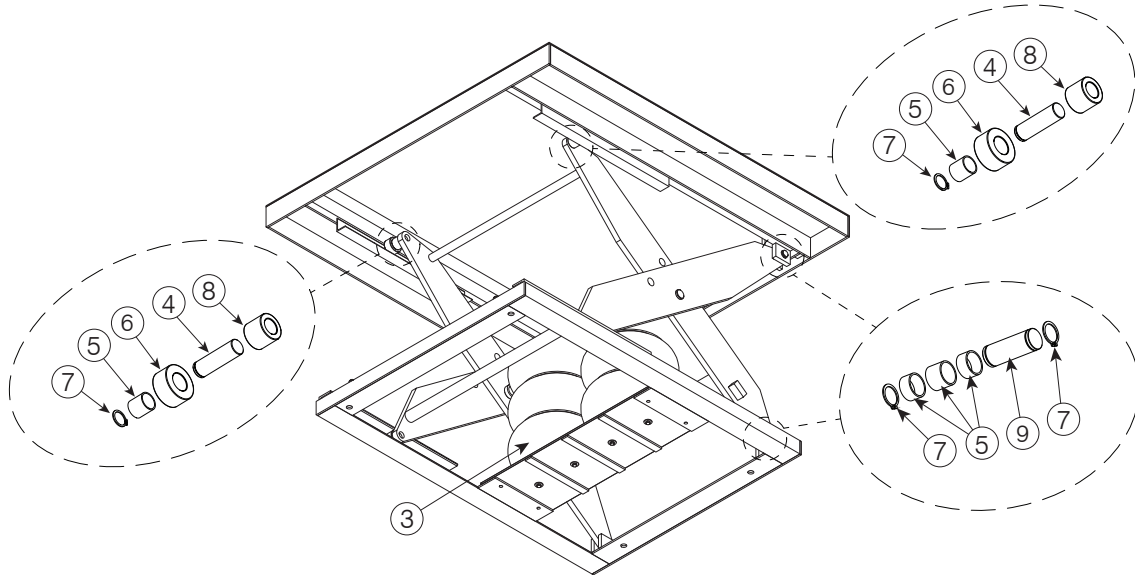

9.5 LIFT TABLE UPPER FRAME AND FIXED END DETAIL

This diagram displays the Lift Table skeleton and the lower frame components.

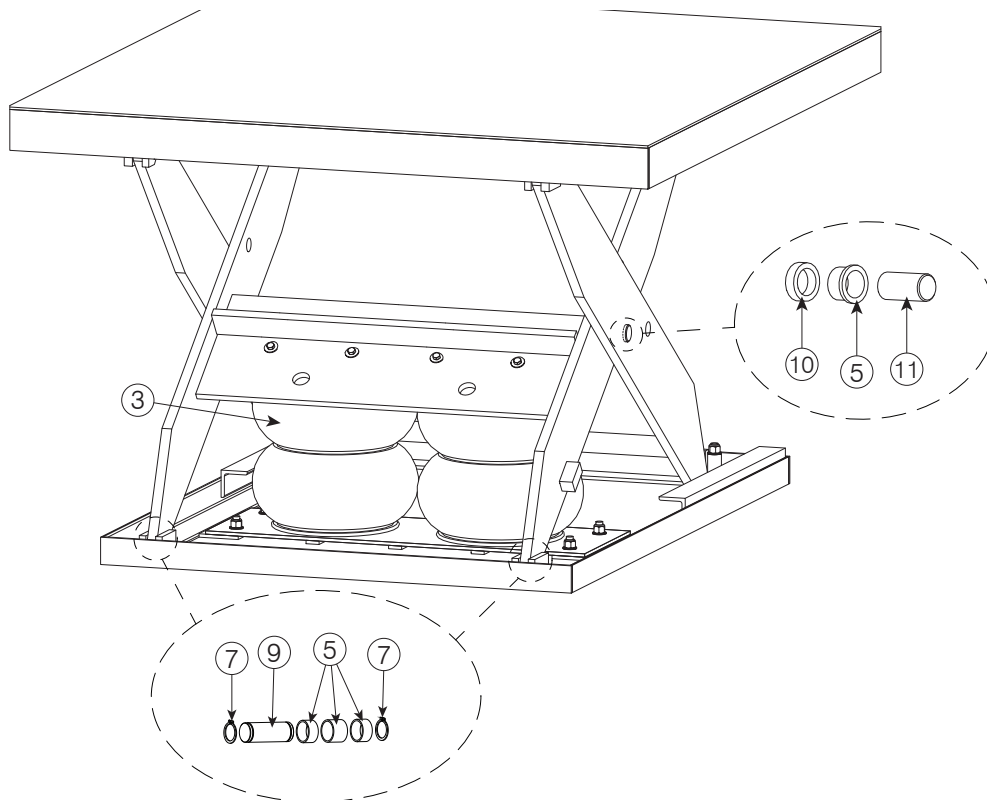

9.6 ACCORDION SAFETY SKIRT

This diagram displays the accordion safety skirt hangers (if present) under the deck and where to anchor it on the lower frame.

NOTE: Actual product may not appear exactly as shown.

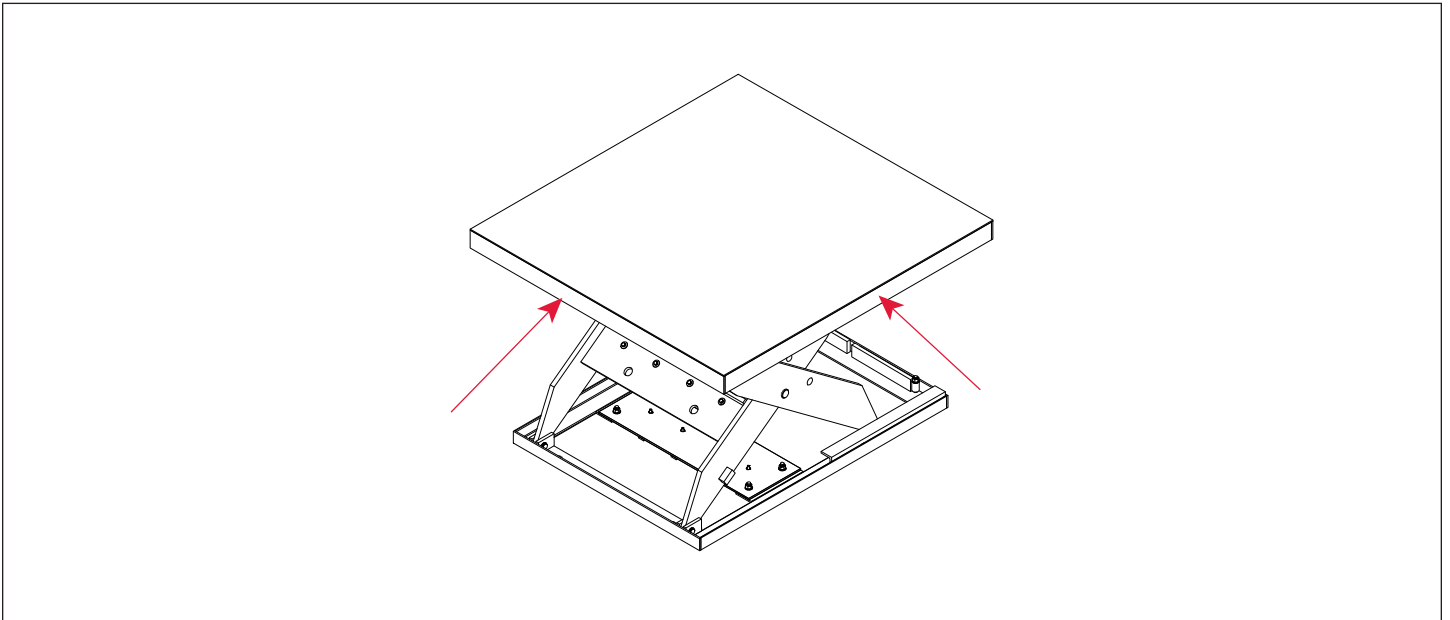

10.0 DECAL IDENTIFICATION AND LOCATION

These labels inform operators and personnel about hazardous areas on and around the lift table.

NOTE: Actual product may not appear exactly as shown.

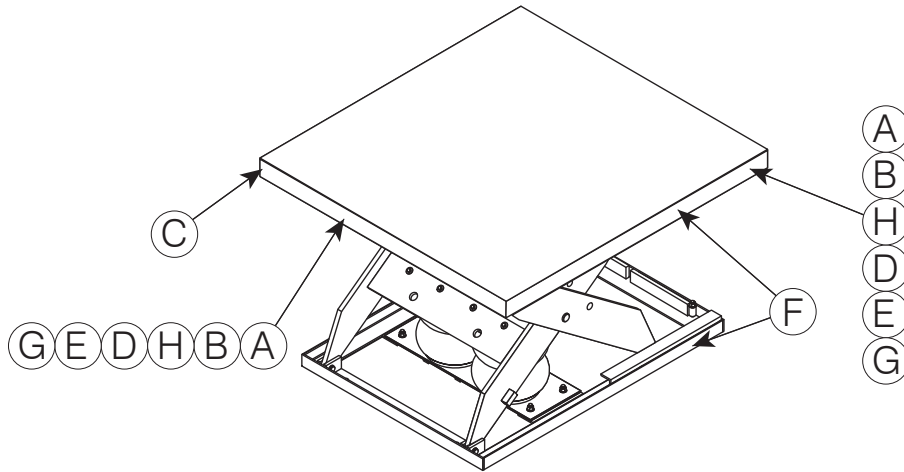
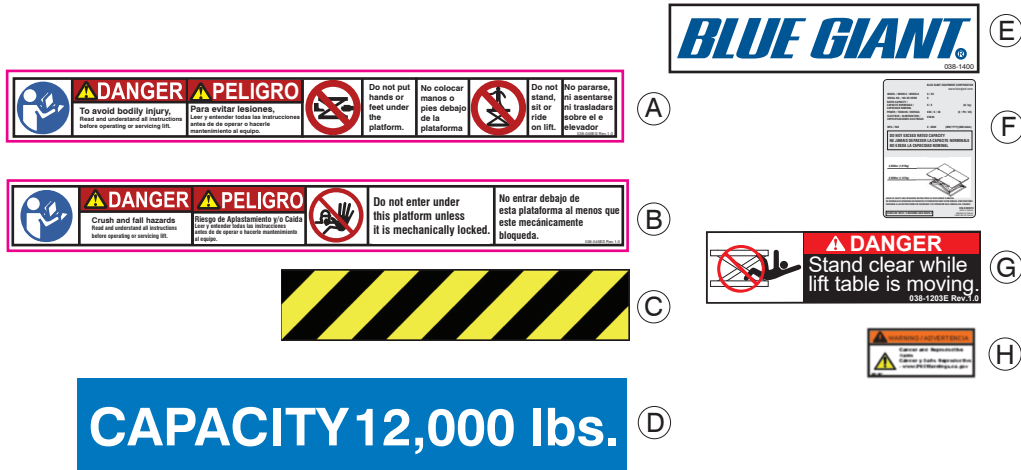

ITEM	QTY	PART NO.		DESCRIPTION
A	2 or 4 (varies on table size)	038-045	EF	Warns personnel to read operating instructions before using the lift table and warn of possible bodily injury
			ES	
B	2 or 4 (varies on table size)	038-046	EF	Warns personnel to employ the Maintenance Strut and Service Stand before working on and under the lift table
			ES	
C	4	038-237		Safety Stripe tape to alert personnel of hazardous areas and edges (i.e. toe guards, edges)
D	2	(varies on model)		Deck Capacity (example only) (locations may vary)
E	2	038-1400		Blue Giant logo (locations may vary)
F	2	038-1106EFS		Nameplate to identify the lift table, serial number, and load transfer capacities
G	1 or 2	038-1203	E	Warns personnel to stand clear of lift table and the immediate area while it is in operation
			S	
H	2	038-1097		Proposition 65 Cancer and Reproductive Harm Warning - California only (locations may vary)

OPERATION PLACARD

The Operation Placard (Part. No. 038-545E) is to be wall mounted near the table controls. A duplicate is provided on the following page.



WARNING

APPLIES TO BLUE GIANT SCISSOR LIFTS

Do not operate this scissor lift without proper training and authorization.

READ AND UNDERSTAND THE FOLLOWING:

*The instructions and warnings on this placard and in the owner's manual.
The warnings on the scissor lift decals.*

Do NOT go under the scissor lift platform to clean or perform routine maintenance unless the Maintenance Strut and Service Stand are safely and securely engaged.

Prior to using the scissor lift:

- *Verify that all safety devices (guard rails, restraint chains, toe guards, and warning bells-if equipped) are in place and functioning properly.*
- *Operate the scissor lift through one complete lift / lower cycle and verify its proper operation. Inspect the scissor lift for signs of structural damage or mechanical malfunction. If damage is observed or the unit fails to operate properly, remove them from service and notify maintenance personnel immediately.*

Do NOT exceed the capacity as stated on the nameplate.

Ensure that the scissor lift serial nameplate is present and legible.

Do NOT leave the control station where it can be accidentally operated or damaged.

Be aware that lift capacity may be reduced when loads are rolled over the platform sides or edges. Refer to the nameplate for reduced capacity under these conditions.

If loads are mobile, secure them in a fixed position before operating the scissor lift.

Lift operator(s) must be present during all steps of operation.

Lift operator(s) must keep an unobstructed view of lift, any operation light/horn/bell, and other operators to ensure safe operation.

Ensure that all personnel near the scissor lift are aware that it is being operated.

Keep objects, control cables, spills, possible trip hazards, and debris away from around or under the scissor lift platform/lip and its travel path.

If the scissor lift is equipped with a hinged bridge(s), the bridge must overlap the trailer bed by a minimum of 4" (102mm) before use. Do not use the bridge if it is supported solely by the lifting chain.

Hinged lips may drop unexpectedly, keep people and objects clear of the area immediately under or near the lip.

If maintenance or service is required:

- *Only authorized service personnel shall provide maintenance / service on the lift.*
- *Follow approved lockout procedures.*
- *Do NOT work on or under the lift without properly engaging the lift's maintenance strut. Blue Giant recommends the use of a secondary means (service stand) of securing the scissor lift while performing repairs under the deck.*
- *The lift shall not be modified or altered without written approval from an authorized Blue Giant representative.*
- *Maintain records of repairs and preventive maintenance reports.*

11.0 EQUIPMENT COMPONENT ILLUSTRATIONS

This section displays the various hardware components.

11.1 COMPONENTS AS SHIPPED CHECKLIST

This section displays the shipped hardware components.



(B)

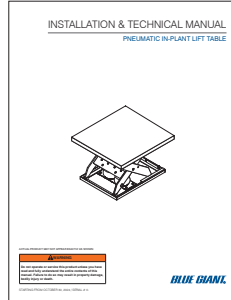

(C)

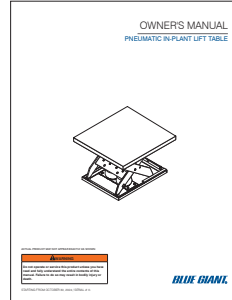

(D)

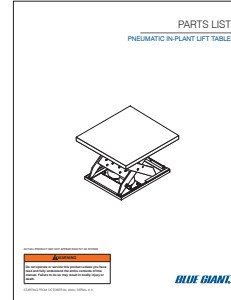

(E)

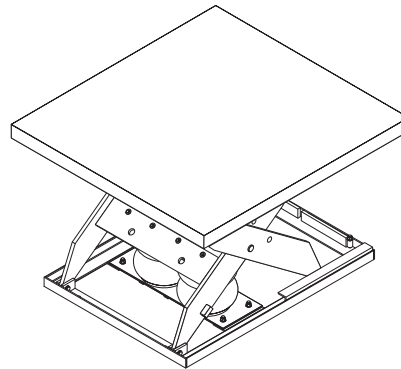

(A)

✓	CALLOUT	QTY.	PART NO.	DESCRIPTION	APPROX. WEIGHT
	A	1	Model Dependent	Lift Table	Varies by Model
	B	1	038-545E	Operation/Warning Placard	—
	C	1	038-611EI	Installation Manual	—
	D	1	038-611E	Owner's Manual	—
	E	1	038-611EPL	Parts List	—

11.2 LIFT TABLE MECHANICAL ASSEMBLY

This diagram shows a detailed view of the lift table assembly.

NOTE: Actual product may not appear exactly as shown.

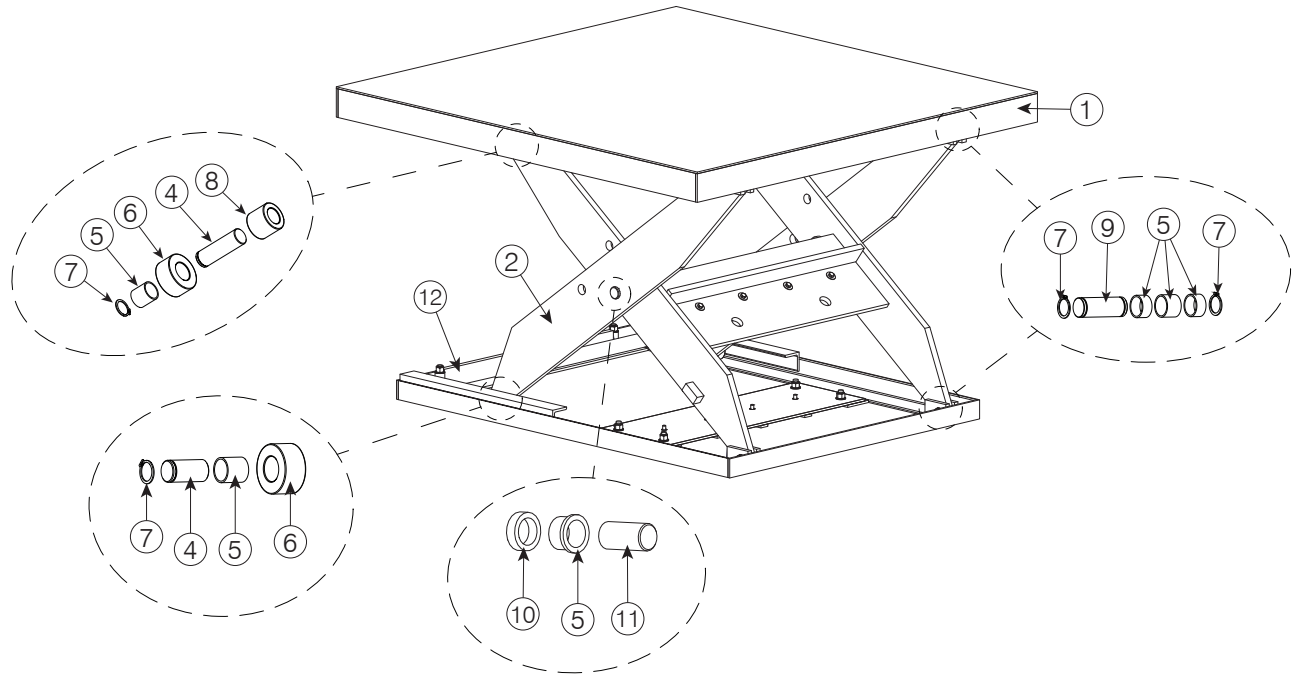



ITEM	QTY	PART NO.	DESCRIPTION
1	1	Varies on Model	WELDMENT,DECK,LFT
2	1	Varies on Model	ASSY,LEG/FRAME,LFT
3	2	071-0226	AIR SPRING,3 FOLD,11 7/8 OD,4 1/2 TO 18
4	4	071-0106	WHEEL PIN,LOWER,7/8ODX1-3/4 L
5	12	071-0019	BUSHING,1.252X1.502X0.50
6	4	071-0104	STEEL,WHEEL,2"OD,1"HOLE
7	12	071-0072	RETAINING RING,EXTERNAL,7/8"
8	2	071-0103	STEEL,WHEEL SPACER,1 1/2 OD,7/8 ID
9	4	071-0102	LEG BLOCK PIN, 0.87ODX2-3/8L
10	2	090-848	STEEL TUBE 2"OD X 1/4"WALL X2 3/4"L
11	2	2022095	LFT CNTR PIN,1 1/4"DIA X2 1/2"L
12	2	090-835	STEEL, BAR, FLAT, REC, 2"X3/4"
13	2*	2030534	1/4" CLEAR PLASTIC TUBING*
14	1*	2023640	1/4" CLEAR PLASTIC TUBING*
15	2*	2023635	FTNG;ELBOW;90DEG; 3/8JIC
16	1*	2023637	MALE TEE, BRASS, 1/4IN, MNPT
17	1	040-054	VALVE,AIR RELIEF VALVE,135PSI,NPTM,1/4

* Contact Blue Giant customer support - Quantity / Length may vary due to configuration or airbag quantity.

12.0 TROUBLESHOOTING

Use this section to help diagnose issues if the lift table is not operating as specified.

 DANGER
<ul style="list-style-type: none"> • Failure to properly secure the lift table deck prior to working underneath it may result in bodily injury, or death. • Engage the Maintenance Struts before visual inspecting or cleaning under the deck. If the struts cannot be successfully engaged, contact your Blue Giant Dealer.

 WARNING
<ul style="list-style-type: none"> • Do not attempt to install, make repairs, or adjustments. Only a trained and authorized service technician should perform the installation process, make repairs, or make adjustments. Contact your Blue Giant Dealer for assistance. • Do not service this equipment until you have read and understood all of the safety information and instructions contained herein. Failure to adhere to recommended safety practices in this manual and on the lift table equipment warning labels could result in death or serious injury. • Do not conduct maintenance or repairs until adequate barriers have been placed to keep warehouse and vehicle traffic away from the work area. • Before doing any Pneumatic work, verify that the Pneumatic energy source is disconnected and properly tagged or locked out, in accordance with OSHA regulations and approved Pneumatic codes. • When conducting maintenance, use only Blue Giant approved lubricants. Improper lubrication or adjustments may cause operational problems.

Following description of operating principles is intended as a guide when trouble shooting and making adjustments or repairs. If no fault can be found and equipment fails to operate properly, contact your Blue Giant Equipment Dealer.

- Pressing the **UP** push button energizes pump which supplies air under pressure to airbag(s) for lifting the deck. A check valve (inside pump or in line) prevents any back flow of air through pump when it is shut off.
- Pressing the **DOWN** push button opens lowering valve which allows air from the airbag(s) to be removed. Lowering speed is controlled by load lowering valve. Lowering is factory set for safe lowering and normally requires no further adjustment.
- If a limit switch is used to control upward travel, it is connected in series with the **UP** push button switch.
- Upward travel of the deck is limited by stops on the leg roller tracks of the lower frame (in some cases internal stops within airbag(s) are used to limit travel). These stops should never be used to position deck at intended raised height.

PROBLEM	PROBLEM CAUSED
Deck will not raise.	<p>Foreign material lodged between side of deck and lower frame. Remove and discard foreign material as required.</p> <p>Equipment or goods parked on lift table deck. Remove and test operate the lift table. Verify lift table capacity before resuming.</p> <p>Filter may have blockages. Clean or replace suction filter.</p> <p>Pump not running at correct system pressure. Replace / repair if necessary.</p> <p>UP push button/open circuit. Check for open circuit in UP limit set improperly contact block or broken wire in harness.</p> <p>Interlock devices. Check all switches.</p> <p>Shipping bolts not removed. Remove.</p> <p>Pneumatic hose pinched. Check hose for pinching, folding, or object on top of hose.</p>
The lift table deck does not maintain steady height.	<p>Air leak may be present. Repair leak.</p> <p>Motor check valve is defective. Replace, if necessary.</p> <p>Down valve is defective. Replace, if necessary.</p>
The lift table deck locked in "UP" position. When DOWN button is pushed, a click can be heard.	<p>Velocity valve locked. Contact your Blue Giant Dealer.</p> <p>If equipped, lowering speed valve closed. Open to set proper lowering speed.</p>
Deck will not lower. No clicking sound heard when a button is pressed.	<p>DOWN push button broken / open circuit. Check for open circuit in contact block, broken wire in harness. Scissor leg bushings seized.</p> <p>Lowering valve defective. Replace.</p>
Deck raises slowly.	<p>Pressure relief bypassing. Foreign material lodged between ball and seat. Contact your Blue Giant Dealer.</p> <p>Weight overload. Remove weight until load matches nameplate weight capacity rating.</p>

13.0 OPTIONAL EQUIPMENT

These components are available as additional options for the Lift Table.

13.1 SAFETY FEATURES

These features provide greater personnel protection and operating awareness.

- Keyed lock and E-Stop push button options on push button controls. Keyed lock provides greater security and access control. E-Stop provides protection for personnel and material.
- Factory set up travel limit switch limits the maximum vertical elevation of the lift table.
- Accordion safety skirting acts as a barrier to keep under the lift table clean and provide personnel awareness.

14.0 PNEUMATIC SCHEMATICS

NOTICE

The following Pneumatic schematic are sample configurations only. Pneumatic schematic specific to your needs will be provided inside the control panel and/ or as part of your submittal package.

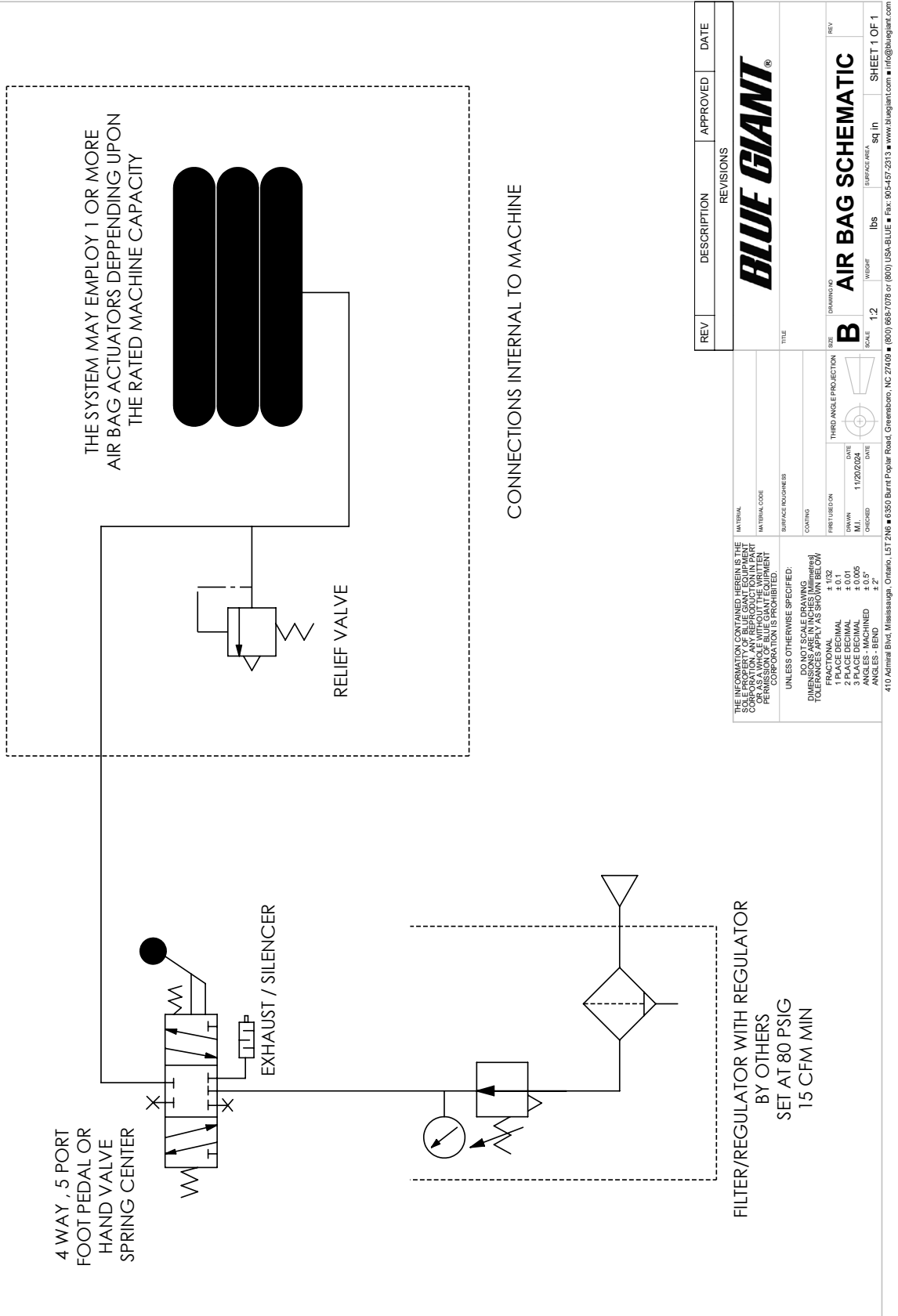

BLUE GIANT[®]
BLUE GIANT EQUIPMENT CORPORATION

Corporate 410 Admiral Blvd
Mississauga, ON, Canada L5T 2N6
t 905.457.3900 f 905.457.2313

USA 9201 National Turnpike
Louisville, KY 40118
www.bluegiant.com