

# OWNER'S MANUAL

## VERTICAL STORING DOCK LEVELER WITH BLUE GENIUS™ TOUCH CONTROL



ACTUAL PRODUCT MAY NOT APPEAR EXACTLY AS SHOWN

 **WARNING**

Do not operate or service this product unless you have read and fully understand the entire contents of this manual. Failure to do so may result in property damage, bodily injury or death.



**TABLE OF CONTENTS**

<b>1.0</b>	<b>ABOUT THE VERTICAL STORING DOCK LEVELER WITH BLUE GENIUS™ TOUCH CONTROL</b>	<b>4</b>
1.1	OWNER'S PURCHASE RECORD	4
<b>2.0</b>	<b>INTRODUCTION</b>	<b>5</b>
2.1	WARRANTY INFORMATION	5
2.2	EXCLUSION OF LIABILITY	5
2.3	MANUFACTURER'S NOTE	5
2.4	OWNER'S RESPONSIBILITY	6
<b>3.0</b>	<b>OWNER'S MANUAL SAFETY MESSAGE COLOR IDENTIFICATION</b>	<b>7</b>
3.1	OPERATIONAL SAFETY WARNINGS	7
<b>4.0</b>	<b>LOCKOUT / TAGOUT PROCEDURE AND RULES</b>	<b>8</b>
4.1	ELECTROSTATIC SENSITIVE DEVICE PROTECTION POLICY	8
<b>5.0</b>	<b>CONTROL PANEL OPERATION</b>	<b>9</b>
5.1	BUTTON FUNCTION	9
<b>6.0</b>	<b>SAFETY STAND AND MAINTENANCE STRUT SET-UP</b>	<b>10</b>
6.1	ENGAGING THE SAFETY STAND	10
6.2	DISENGAGING THE SAFETY STAND	10
6.3	ENGAGING THE MAINTENANCE STRUT	10
6.4	DISENGAGING THE MAINTENANCE STRUT	10
<b>7.0</b>	<b>MAINTENANCE</b>	<b>11</b>
7.1	PLANNED MAINTENANCE PROGRAM (PMP)	11
7.2	OPERATOR DAILY INSPECTION	11
7.3	ROUTINE SERVICING AND MAINTENANCE	11
7.4	PLANNED MAINTENANCE PROGRAM INTERVALS	11
7.5	MAINTENANCE SEQUENCE	11
7.6	RECOMMENDED HYDRAULIC FLUIDS	11
7.7	DAILY MAINTENANCE PROCEDURES CHECKLIST - VERTICAL DOCK	12
<b>8.0</b>	<b>OPERATING INSTRUCTIONS</b>	<b>13</b>
8.1	FUNCTIONAL DESCRIPTION	13
8.2	STOP BUTTON FUNCTION	14
8.3	STARTING PROCEDURE	14
8.4	DEPLOYING THE DOCK LEVELER	15
8.5	DEPLOYED ON TRAILER	15
8.6	RETURNING DOCK LEVELER TO THE HOME POSITION	16
8.7	DEPLOYING THE DOCK LEVELER: BELOW LEVEL / END LOADING	16
8.8	RETURNING TO NORMAL LIP-ON TRAILER OPERATION	18
<b>9.0</b>	<b>OVERHEAD DOOR INTERLOCK</b>	<b>19</b>
9.1	OVERHEAD DOOR SENSOR (OPTIONAL)	19
9.1.1	OVERHEAD DOOR NOT FULLY OPEN	19
9.1.2	OVERHEAD DOOR CLOSED DURING OPERATION	19
9.1.3	OVERHEAD DOOR CLOSED WHILE DOCK IS DEPLOYED	20
<b>10.0</b>	<b>RECOMMENDED SPARE PARTS</b>	<b>21</b>
10.1	STANDARD OPERATIONAL COMPONENTS	21
10.2	OPTIONAL SUPPORT COMPONENTS	23

**TABLE OF CONTENTS CONT'D.**

<b>11.0</b>	<b>DECAL IDENTIFICATION AND LOCATION</b>	<b>24</b>
<b>12.0</b>	<b>EQUIPMENT COMPONENT ILLUSTRATIONS</b>	<b>25</b>
12.1	COMPONENTS AS SHIPPED CHECKLIST	25
<b>13.0</b>	<b>MECHANICAL ASSEMBLY</b>	<b>27</b>
13.1	VERTICAL DOCK DECK SIZE AND CAPACITIES	29
13.2	VERTICAL DOCK LIP SIZE AND CAPACITIES	30
13.3	VERTICAL DOCK BACK FRAME SIZE	31
13.4	PIT DIMENSIONS - T-STYLE PIT	32
13.5	PIT DIMENSIONS - CONTINUOUS PIT	32
13.6	POWERPACK PART IDENTIFICATION	33
13.7	MANIFOLD PART IDENTIFICATION	34
13.8	CONTROLS	35
13.9	STANDARD REMOTE I/O	36
13.10	OPTIONAL DOOR REMOTE I/O	36
13.11	OPTIONAL EXTERIOR TRAFFIC LIGHT / MIRROR IMAGE SIGN	37
<b>14.0</b>	<b>DOCK LEVELER TROUBLESHOOTING</b>	<b>38</b>
<b>15.0</b>	<b>BLUE GENIUS™ LCD MESSAGES</b>	<b>40</b>
<b>16.0</b>	<b>WIRING DIAGRAMS</b>	<b>40</b>
16.1	WIRING DIAGRAM—115V SINGLE PHASE	41
16.2	WIRING DIAGRAM—208-600V THREE PHASE	42

**1.0 ABOUT THE VERTICAL STORING DOCK LEVELER WITH BLUE GENIUS™ TOUCH CONTROL**

The Blue Giant Vertical Dock Leveler enables a complete energy efficient seal. The dock is stored in the vertical position inside the building, allowing the overhead door to close completely, which reduces door damage, prevents energy loss and debris entry, and improves security levels. It is the perfect loading dock solution for facilities that must maintain strict temperature or humidity controls.

The Blue Genius™ Gold Series I Touch Control Panel features include an LCD menu screen, function buttons ('DECK', 'LIP', 'DOWN', 'STOP'), and a flat-surface keypad with unique touch sensors.

**1.1 OWNER'S PURCHASE RECORD**

<b>OWNER'S PURCHASE RECORD</b>	
Please record information for future inquiries and to validate warranty. (See Section 2.1 for warranty validation)	
<b>Dealer:</b>	<b>Date in Service:</b>
	<b>Number of Units:</b>
<b>Serial Number:</b>	<b>Door #:</b>
<b>Serial Number:</b>	<b>Door #:</b>
<b>Serial Number:</b>	<b>Door #:</b>
<b>Serial Number:</b>	<b>Door #:</b>
<b>Serial Number:</b>	<b>Door #:</b>
<b>Serial Number:</b>	<b>Door #:</b>
<b>Serial Number:</b>	<b>Door #:</b>
<b>Serial Number:</b>	<b>Door #:</b>
<b>Serial Number:</b>	<b>Door #:</b>
<b>Serial Number:</b>	<b>Door #:</b>
<b>Serial Number:</b>	<b>Door #:</b>

<b>NOTICE</b>
See Section 11.0 "Decal Identification and Location" item #1 for serial number location.

The manufacturer offers a full line of dock levelers, dock safety equipment, accessories, ergonomic and scissor lift equipment, seals and shelters, and industrial trucks. Concurrent with a continuing product improvement program, specifications are subject to change without notice (see Section 2.2 "Exclusion of Liability"). Please contact the manufacturer for latest information. Some features illustrated may be optional in certain market areas.

**2.0 INTRODUCTION**

The following is a quick reference to important procedures that must be followed while using the Loading Dock Equipment. It is not intended to cover, or suggest that it does cover, all procedures necessary to ensure safe operation. All operators should be aware of and abide by all workplace safety regulations applicable to the operation of the Loading Dock. These laws and regulations include but are not limited to:

- The Occupational Safety and Health Act
- Canada Occupational Health and Safety Regulations
- Occupational Safety and Health Acts for Individual States (USA), Provinces, or Territories.

For additional information on these regulations as well as industry standards that may apply to this product, please contact:



American National Standards Institute (ANSI)  
 1430 Broadway  
 New York, NY 10018  
 Telephone: 212.642.4900  
 www.ansi.org

Also a member of:



Loading Dock Equipment Manufacturers  
 A Product Section of Material Handling Industry of America  
 A Division of Material Handling Industry  
 8720 Red Oak Blvd, Suite 201  
 Charlotte, NC, 28217-3992  
 Telephone: 704.676.1190  
 www.mhi.org/lodem

**2.1 WARRANTY INFORMATION**

Thank you for purchasing Blue Giant products. We appreciate your business, and are confident that our product will serve you for many years to come. In the event that you experience a problem with our product, our Customer Support Team is here to support the Blue Giant Product(s) that you have purchased.

To validate warranty on recently purchased equipment, please complete and submit your information with our online Warranty Registration at [www.BlueGiant.com](http://www.BlueGiant.com).

**DEALER INFORMATION**

**Name:** \_\_\_\_\_

**Contact:** \_\_\_\_\_

**Telephone:** \_\_\_\_\_

To validate warranty on recently purchased equipment, please complete and submit your information with our on-line Warranty Registration at [www.BlueGiant.com](http://www.BlueGiant.com).

For more information about Blue Giant Warranty Support, please contact your Blue Giant Dealer. You may also visit [www.BlueGiant.com](http://www.BlueGiant.com) or phone 1.800.872.2583.

**NOTE: All products must be registered to qualify for warranty.**

**2.2 EXCLUSION OF LIABILITY**

To the maximum extent permitted by applicable law, the manufacturer assumes no liability for damage or injury to persons or property that occur as a result of use of the Dock Leveler Equipment. Furthermore, to the maximum extent permitted by applicable law, the manufacturer does not assume any liability for lost profits, operating downtimes, consequential, indirect, incidental, special, exemplary, punitive or enhanced damages, or similar losses, whether incurred by owner, authorized users and other third parties. By use of the Dock Lever Equipment, owner assumes all risk of liability for damage or injury to persons or property that occur as a result of use of the Dock Lever Equipment, including, with respect to owner, authorized users and other third parties. The manufacturer reserves the right to make changes at any time to the modules, components, and accessories, concurrent with its continuing product improvements and development program. Specifications, operating instructions, and illustrations included in this manual are subject to change without advance notice. As the Dock Lever Equipment is a highly customizable product, please contact the manufacturer by telephone at 1.800.872.2583 for the latest information.

## 2.3 MANUFACTURER'S NOTE

The Dock Leveler Equipment has been carefully inspected and tested at the manufacturer's plant prior to shipment, but **MUST be checked** upon receipt for transport damage. Any observed transport damage is to be listed on the signed copy of the freight document. There are many configurations or custom designs whose specifications may not be fully reflected in this manual. Contact your Blue Giant Dealer to obtain the General Arrangement drawing for application specific designs.

**Notify the freight forwarder and the dealer of any damage WITHIN 24 HOURS.**

## 2.4 OWNER'S RESPONSIBILITY

The Dock Leveler Equipment needs to be maintained and inspected by the owner to verify its safe condition for operation.

1. The owner should recognize the inherent danger of the interface between the dock leveler equipment and the freight carrier. The owner should, therefore, train and instruct operators in the safe use of the dock leveler equipment and accessories in accordance with the manufacturer's recommendations.
2. The owner should thoroughly familiarize themselves with the following procedures and specifications as referenced in this manual, and request immediate replacement of all manufacturer-supplied documents that are missing, damaged, or otherwise illegible.

Owners shall apply sound principles of safety, training, inspection, maintenance, and expected operating environment toward their dock leveler equipment usage and maintenance requirements.

  - Commissioning instructions
  - Operating instructions
  - Daily maintenance procedures checklist
  - Inspections procedures
  - Recommended spare parts lists

Upon receipt of any newly purchased dock leveler equipment, the owner shall verify the presence of owner's manuals, operating placards, and any other documentation necessary for training dock personnel how to use the equipment safely and effectively.
3. All Blue Giant dock leveler equipment shall undergo regularly scheduled planned maintenance. Maintenance requirements will vary according to usage frequency and application, so the owner shall contact with their authorized Blue Giant distributor for schedule recommendation. Written records of the performance of these procedures shall be kept as per warranty requirements and per local state or provincial requirements. Please see "7.0 MAINTENANCE" on page 11.
4. Dock leveler equipment that is structurally damaged, experiencing performance irregularities, or has been potentially compromised shall be removed from service until a trained and authorized manufacturer's representative can conduct an inspection and perform any necessary repairs.
5. As with any piece of machinery, dock leveler equipment requires routine maintenance, lubrication, and adjustments. Recommended procedures are itemized in the Planned Maintenance Program (PMP) checklist included in installation and technical manuals. It is recommended that for anything other than the basic maintenance procedures outlined in this manual, please contact your Blue Giant Dealer.
6. The owner shall ensure that all nameplates and safety labels are in place and legible, and that the appropriate manuals are provided to authorized users. Replacement nameplates, safety labels, and manuals are available through the Blue Giant Aftermarket Department. See "11.0 DECAL IDENTIFICATION AND LOCATION" on page 24 in this manual for more information.
7. The owner or a trained and authorized representative shall verify that all freight carrier brakes have been applied and a vehicle restraint and/or wheel chocks properly engaged before cross-docking procedures begin. For safety reasons, trailers must be held securely in place to avoid accidental separation from the loading dock.
8. Unless specifically agreed to in writing by Blue Giant Equipment Corporation at the time of order (and prior to manufacture), all Blue Giant dock leveler equipment is sold as a complete offering and must not be altered or added to in any manner (which includes configuration and function) without written permission from an authorized manufacturer's representative. These changes shall also satisfy all safety recommendations of the original equipment manufacturer for the particular application of the dock leveler equipment.
9. If, at the request of the owner, Blue Giant does not supply all or some of the dock leveler equipment power unit and/or control panel components, the owner shall assume responsibility for any and all operational and safety issues associated with the resulting configuration.
10. The owner must adhere to the load classification information provided on the product nameplate. Failure to do so will void product warranty and can result in serious injury, including death.
11. Operational placard must be visible from equipment location and permanently attached to a wall or structure.
12. The owner shall ensure that inspections are performed to the leveling device as prescribed by law or regulation.

### 3.0 OWNER'S MANUAL SAFETY MESSAGE COLOR IDENTIFICATION

This manual includes color-coded safety messages that clarify instructions and specify areas where potential hazard exists. To prevent the possibility of equipment damage and serious injury or death, please observe strictly the instructions and warnings contained in the messages. If warning decals become damaged or missing, replace them immediately. Avoid accidents by recognizing dangerous procedures or situations before they occur.

<b>⚠ DANGER</b>	<b>NOTICE</b>
Serious injury or death will likely occur if the instructions are not followed.	Procedures marked notice must be followed in order to prevent damage to machinery.
<b>⚠ WARNING</b>	<b>⚠ CAUTION</b>
Serious injury or death may occur if the instructions are not followed.	Instructions marked caution concern safe operating procedure. Failure to comply may result in personal injury.

### 3.1 OPERATIONAL SAFETY WARNINGS

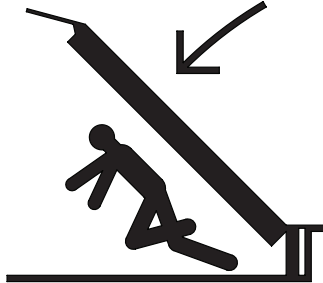
<b>⚠ DANGER</b>	
<p><b>CRUSH HAZARD</b></p> 	<ol style="list-style-type: none"> <li>1. Do not operate leveler with anyone standing in its path.</li> <li>2. Do not service leveler unless the maintenance strut and safety stand have been properly engaged. See SECTION: ENGAGING MAINTENANCE STRUT</li> <li>3. <b>BEFORE BEGINNING ANY SERVICE PROCEDURES:</b> Position the dock leveler in the vertically stored position. Disconnect the power and follow all lockout / tagout procedures in this manual.</li> <li>4. Do not operate leveler without following the procedure below if the leveler has not been in service for an extended period of time.</li> <li>5. <b>PROCEDURE FOR FILLING CYLINDER:</b> Touch and hold the 'UP' button (Run Pump) to operate for thirty-five (35) seconds</li> </ol>
<b>⚠ WARNING</b>	<b>NOTICE</b>
<ul style="list-style-type: none"> <li>• The upper hinge point is a hazardous pinch point. Do not use fingers or hands to remove foreign materials.</li> <li>• Post safety warnings and barricade working area at dock level and at ground level to prevent unauthorized use of the dock leveler during maintenance/service.</li> <li>• During installation, anchors must be properly torqued to obtain the necessary anchoring strength. <b>DO NOT USE IMPACT DRIVERS.</b></li> <li>• Do not drive or walk onto truck/trailer until the truck/trailer is parked against the dock bumpers and the wheels are chocked or the vehicle restraint has been fully engaged and the lights have changed to GREEN inside and RED outside.</li> <li>• Never attempt to lift the lip or hold the lip out by hand. Serious personal injury could occur.</li> <li>• Do not remove lifting equipment until: the main cylinder has been filled and the maintenance stand has been installed and engaged.</li> <li>• Always check the rigging to make sure that it is secure before attempting to lift the unit. Never stand under any unit being lifted.</li> <li>• Never remove the wheel chocks until loading/ unloading is finished and the truck driver has been given permission to drive away from the dock.</li> </ul>	<ul style="list-style-type: none"> <li>• Do not ground welding equipment to any hydraulic cylinder or electrical components.</li> <li>• Do not attach welder as ground to leveler platform when welding on base frame assembly. Attach welder ground to base frame assembly only. Damage to bearings or hydraulic equipment will occur.</li> <li>• Do not allow the drill to go too deeply into the box when drilling holes in the control box. Damage to the control systems may occur.</li> <li>• Never use air to blow debris from control box. Use a vacuum to remove debris from control box.</li> <li>• Do not connect green ground lead into control box or junction box until all welding has been completed.</li> <li>• Check hydraulic fluid level. Deck mounted power unit has been filled with fluid but cylinders, hoses and manifold are shipped dry.</li> <li>• Check motor rotation. Jog the motor until rotation has been determined. Do not allow the motor to run in reverse for more than a couple of seconds, because this will damage the power unit.</li> <li>• Do not force valve adjustment screws against internal stops. Damage will occur to the valve/seat.</li> <li>• If a procedure is not clearly defined in this manual, contact your authorized Service Representative.</li> </ul>

### 3.1 OPERATIONAL SAFETY WARNINGS CONT'D.

**CAUTION**

1. Only trained personnel should operate or service this equipment
2. Do not operate leveler until truck/trailer is parked against the dock bumpers and the truck/trailer has been secured
3. Always return the leveler platform to the proper stored position
4. Always conduct routine inspections and maintenance. Failure to conduct could cause personal injury or damage to equipment
5. Always call your authorized service representative or manufacturer immediately if a malfunction occurs

### 4.0 LOCKOUT / TAGOUT PROCEDURE AND RULES

In accordance with the rules and regulations of the Occupational Safety and Health Administration (OSHA), all affected employees must be notified that the machine or equipment will be shut down and locked out to perform repair or maintenance work. The work area must be checked to ensure that all personnel have been removed or safely repositioned. The machine or equipment power supply shall be locked in the **OFF** position or disconnected from the energy source. Blue Giant strongly recommends that only OSHA-approved lockout devices be utilized.

The energy isolating device must bear a prominent warning tag indicating that work is being done on the equipment and the name of the authorized employee responsible for the lockout. It is mandatory that tagout notices **NOT** be susceptible to deterioration or illegibility due to weather conditions or exposure to chemicals and moisture.

**WARNING**

Always lockout and tagout any power source before performing any work on any electrical devices or electrical controls according to OSHA regulations and approved local electrical codes. Refer to wiring diagrams.

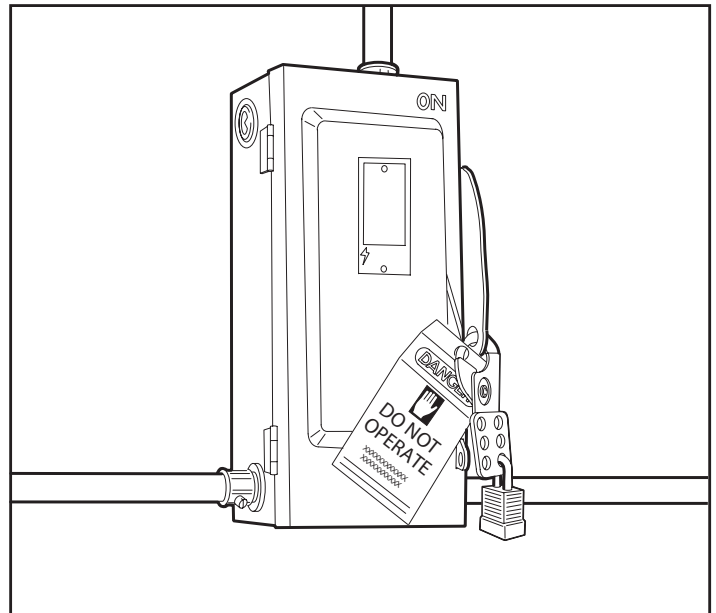

An example of lockout / tagout. Verify and comply with local codes / regulatory requirements.

### 4.1 ELECTROSTATIC SENSITIVE DEVICE PROTECTION POLICY

This policy applies to static sensitive electronic products primarily printed circuit boards (PCBs) and sensors. Switches, relay, lamps and wire are not sensitive and do not apply. If welding near ESD components, correctly protect and ground all necessary equipment.

1. Prior to handling PCBs, wear a static grounding wrist strap and clip it to an electrical ground. The metal plate on the inside of the wristband must be in contact with the wearers skin.
2. PCBs should never be handed to other personnel or set down anywhere.
3. Place PCBs in black ESD shielding bags for return or storage. Only one PCB or sensor should be placed in a static bag. Attach paperwork and other items to the outside with adhesive pouches or elastic bands.
4. The control boxes protect the PCBs inside from static, and should not be used to store manuals or other accessories.

**ATTENTION**



**OBSERVE PRECAUTIONS FOR HANDLING ELECTROSTATIC SENSITIVE DEVICES**

**DO NOT DISCARD.** Any components shipped back to Blue Giant must be in their original packaging (along with completed RGA form taped to the **OUTSIDE** of the static bag) or warranty may be voided.

038-850E

**5.0 CONTROL PANEL OPERATION**

INDEPENDENT TYPE CONTROL PANEL

Controls one individual dock leveler only, equipped with touch buttons, inside forklift operator traffic lights, operator menu screen, and keypad for coded features.

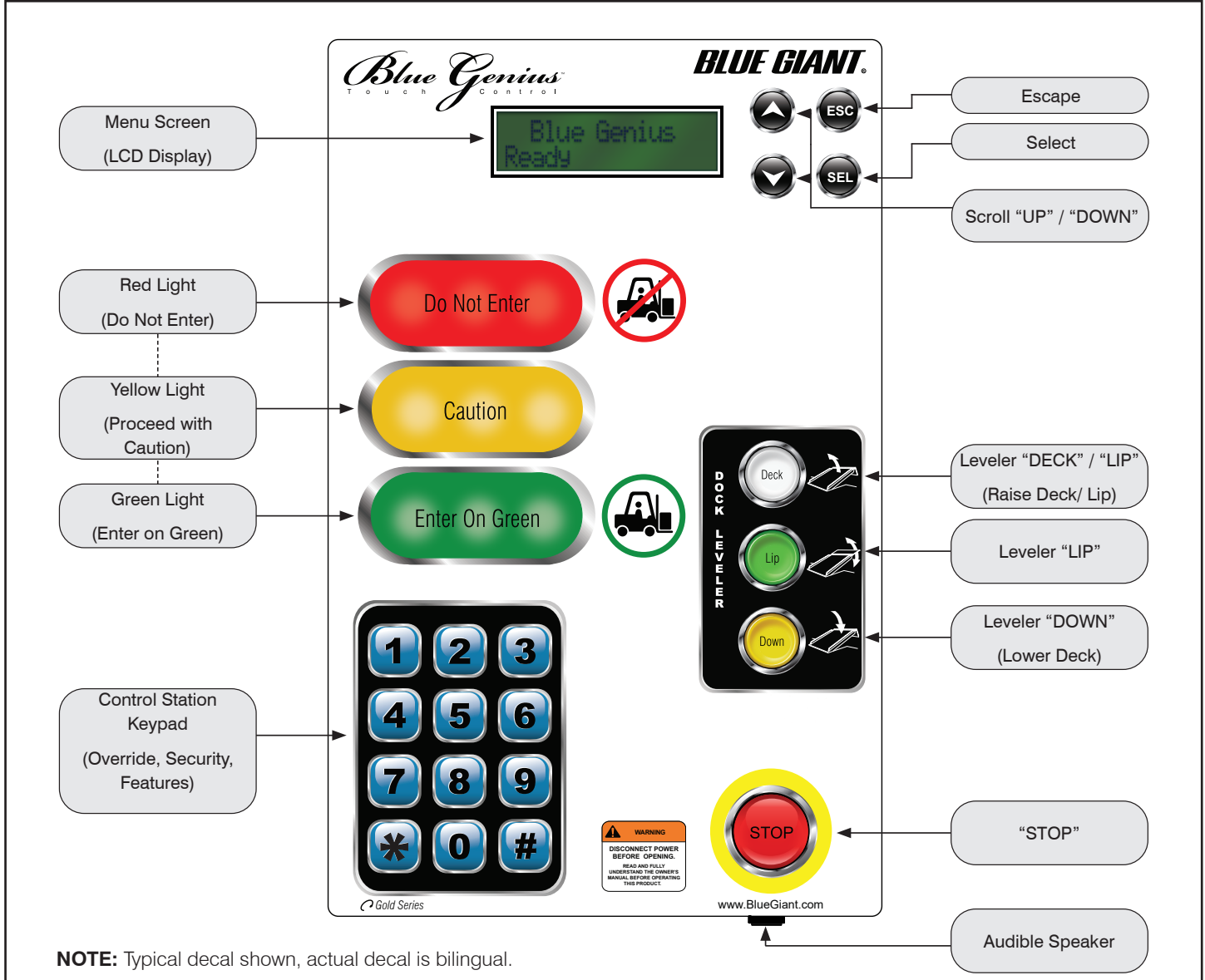

**5.1 BUTTON FUNCTION**

When touching any of the function buttons or keypad, use the ball of the finger. The control station's unique touch sensors detect the proximity of the dock operator's finger. Audible touch buttons and keypad on the Blue Genius™ provide instant sound feedback to user input.

The 'Deck,' 'Lip,' and 'Down' buttons require constant contact to activate their respective functions.

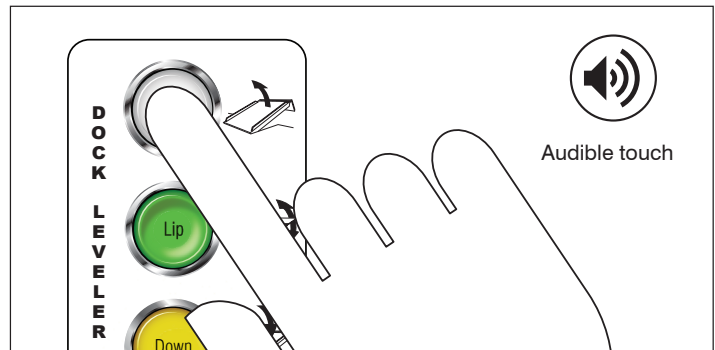

## 6.0 SAFETY STAND AND MAINTENANCE STRUT SET-UP

### DANGER

Never work in the path of the dock leveler platform without engaging the safety stand and/or maintenance strut. If you are unable to successfully engage the device, contact your authorized service representative or the manufacturer.

### WARNING

Post safety warnings and barricade work area at dock level and at ground level to prevent unauthorized use of the dock leveler during maintenance/service.

### 6.1 ENGAGING THE SAFETY STAND

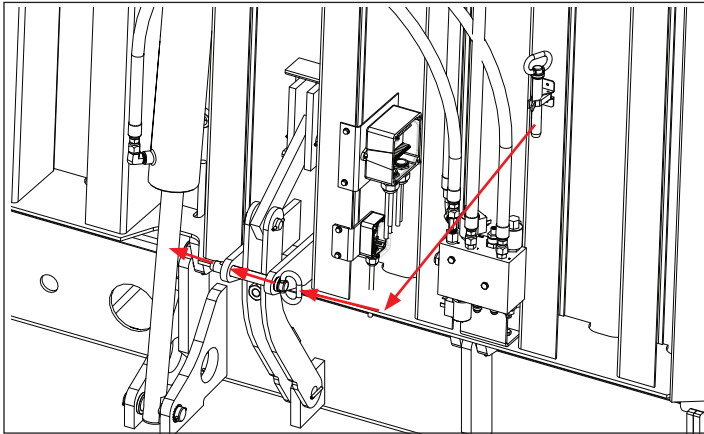

1. Standing at a safe position next to the dock leveler, carefully remove the lock pin (part # 013-077) from its holder (part # 013-537).
2. Slide the lock pin through the bracket holes.
3. The safety stand is now engaged.

### 6.2 DISENGAGING THE SAFETY STAND

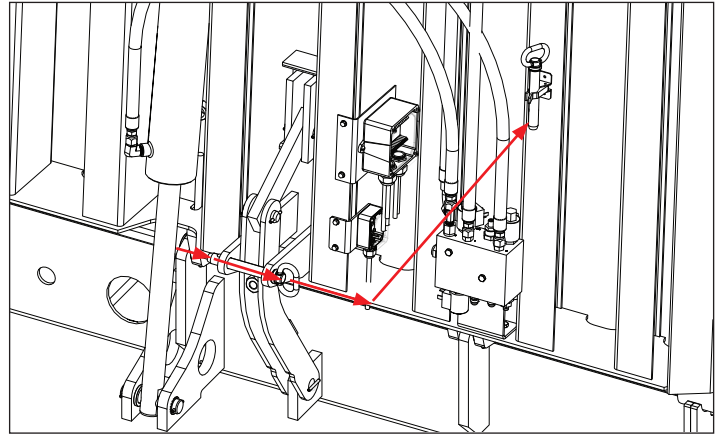

1. When all work is complete, return to a safe position next to the dock leveler and carefully pull out the lock pin.
2. Return the lock pin to its holder.
3. The safety stand is now disengaged.

### 6.3 ENGAGING THE MAINTENANCE STRUT

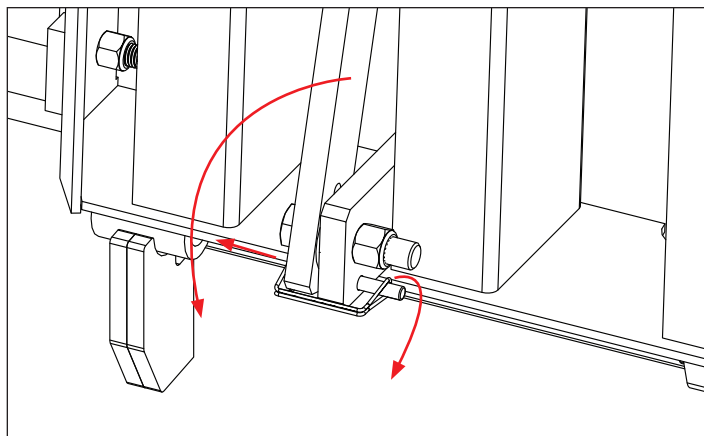

1. Standing at a safe position next to the dock leveler, carefully remove the lynch pin (part # 013-078).
2. Lower the maintenance strut to the engaged position and reinsert the lynch pin.
3. The maintenance strut is now engaged.

### 6.4 DISENGAGING THE MAINTENANCE STRUT

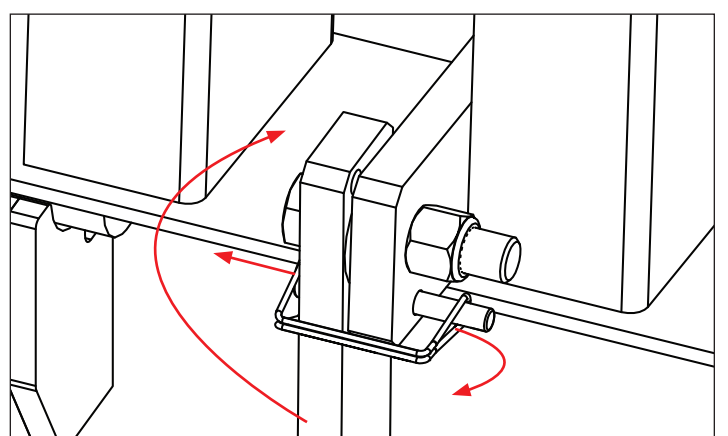

1. When all work is complete, return to a safe position next to the dock leveler and carefully pull out the lynch pin.
2. Raise the maintenance strut to the disengaged position and return the lynch pin to its holder.
3. The maintenance strut is now disengaged.

**7.0 MAINTENANCE**

 **WARNING**

Do not operate and/or service this dock leveler until you have read and understood all of the safety information and instructions contained herein and on the dock leveler.

Do not work under or around dock leveler without first placing adequate barriers to positively prevent vehicle traffic from entering the work area.

Follow proper lock-out/tag-out procedures.

Keep hands and feet clear of dock leveler pinch points and wear appropriate safety attire – safety glasses, gloves and work boots.

The maintenance strut and safety stand must be in place before commencing maintenance procedures.

**7.1 PLANNED MAINTENANCE PROGRAM (PMP)**

In addition to the Daily Maintenance Procedures (DMP), the manufacturer recommends (and local government regulations may require) that a Planned Maintenance Program (PMP) and safety inspection program be performed by a trained and authorized service technician on a regular basis to ensure the equipment is in safe operating condition. The PMP will provide an opportunity to make a thorough inspection of the safety and operating condition of the dock leveler. Necessary adjustments and repairs can be done during the PMP, which will increase the life of components and reduce unscheduled downtime.

Recommended procedures for a periodic planned maintenance program that covers inspections, operational checks, cleaning, lubrication, and minor adjustments are outlined in the Installation and Technical manual for this product.

An authorized dealer or distributor is prepared to assist with a planned maintenance program by offering trained service personnel with expertise in dock leveler maintenance requirements.

**7.2 OPERATOR DAILY INSPECTION**

The dock leveler should always be examined by the operator PRIOR TO ANY USE to verify that it is safe to operate.

The manufacturer recommends making multiple photocopies of the DMP Checklist (See Section 7.7). The operator should fill out this form to keep a daily record of operation and maintenance issues.

**7.3 ROUTINE SERVICING AND MAINTENANCE**

Regular maintenance and care of the dock leveler is very important for cost and operation efficiency and more importantly; operator safety. A faulty dock leveler is a potential source of danger to the operator, and to other personnel working near it. As with all quality

equipment, keep the dock leveler in good operating condition by following the recommended schedule of maintenance.

Failure to properly maintain or operate the dock leveler within its rated capacity can void the manufacturer warranty.

**7.4 PLANNED MAINTENANCE PROGRAM INTERVALS**

Arrange for a qualified dock leveler repair technician to perform regularly scheduled planned maintenance on your dock leveler every three months for single shift operations or monthly for multi-shift operations. Call your authorized manufacturer / dealer for further details.

**7.5 MAINTENANCE SEQUENCE**

1. Cleaning, including pit area
2. Visual inspection of all components
3. Lubrication, as required (by a trained service technician only)
4. Test operate all functions
5. Adjustments, if required (by a trained service technician only)
6. Check for missing or damaged dock bumpers
7. Record inspection details and findings for owners' files

**7.6 RECOMMENDED HYDRAULIC FLUIDS**

Blue Giant has the following hydraulic oils available:

PART NO.	DESCRIPTION
091-031	Standard hydraulic oil, MV22
090-624	Hydraulic arctic oil, MV15
091-286	Hydraulic biodegradable oil, BIO 40

**NOTICE**

Use of other oil products may damage equipment

Transportation laws classify these oils as hazardous material, so they cannot be shipped to customers. Pick-up purchases only. If assistance is needed to locate a source of hydraulic oil for Blue Giant dock equipment, contact a local Blue Giant dealer.

### 7.7 DAILY MAINTENANCE PROCEDURES CHECKLIST - VERTICAL DOCK

INSPECTED BY: \_\_\_\_\_ DATE: \_\_\_\_\_

SERIAL #: \_\_\_\_\_ DOOR #: \_\_\_\_\_

Forward this checklist to the person responsible for dock equipment maintenance. See Section 1.1 "Owner's Purchase Record" for Date in Service.

INSTRUCTIONS FOR USE: Indicate "OK for USE" with a check mark ✓ in the appropriate box of each inspection point.

**EVERY DAY (MAY BE PERFORMED BY OWNER OR ATTENDANT):**

- Remove any debris that may have accumulated around the dock equipment and sweep any debris out of the lip hinge (if equipped).
- Verify complication-free operation of the dock equipment and the interior and exterior lights system (if installed).
- Verify that outside signage is present and legible (if equipped).
- Remove any potential trip hazards from around the dock area.
- Verify that dock bumpers/risers/extensions are in working condition (if equipped).
- Check curb angles and backframe for irregularities (e.g. concrete cracks)
- Verify that the maintenance strut and safety stand are functional
- Verify that instructional caution and danger labels are present and legible on the product. Replace if necessary.
- Verify that vehicle restraint or wheel chocks at minimum are present and in working condition.
- Verify that the push button station is not damaged and electrical cord is not frayed or has exposed wires.
- Verify if the hydraulic system has any leaks (oil drops/pooling), loose fittings, or cracked/rotted/sliced hoses.
- Verify if the dock leveler has developed a tilt, any visible damage, or produces unusual noises while moving.
- Verify complication free operation of the equipment through a complete cycle (refer to Operation Placard).
- \_\_\_\_\_
- \_\_\_\_\_

**PHOTOCOPY THIS CHECKLIST AND FILL OUT REGULARLY FOR YOUR RECORDS.**

Explain faults briefly in the space provided below:

---

---

---

---

---

---

**⚠ DANGER**

When repairing or conducting maintenance procedures on electrical components, perform lockout / tagout steps according to OSHA regulations and approved electrical codes.

**⚠ DANGER**

Prior to installation, place adequate barriers to prevent unauthorized personnel and vehicle traffic from entering the work area.

**⚠ WARNING**

All repairs and maintenance work are to be conducted by trained and authorized personnel ONLY.

**8.0 OPERATING INSTRUCTIONS**

**WARNING**

Do not operate this leveler unless you have been trained and authorized to do so, and have read and understood all of the safety information and instructions contained herein.

Do not operate the dock leveler beyond its rated capacity.

Verify visually on the Blue Genius Control Panel and around the dock area that all doors (facility, trailer, or vehicle), paths, and interlocks (if present) required for load transfer are fully open, unobstructed, and functioning BEFORE operating the dock leveler. Do not enter the area around, under, or be on the dock leveler if it is in motion.

Do not operate this leveler until you have checked its condition. Report the need for repairs to your supervisor immediately and do not operate the unit until repairs are made. Neglect may cause a minor repair to become a major service problem and cause the leveler to become unsafe.

Never try to lift or move any part of the dock leveler manually.

Do not drive on the leveler unless the lip is securely on the truck bed and has a minimum of 4" (102mm) overlap on its surface.

Do not exceed 4 mph when driving over the dock leveler.

Do not drive over edges of the leveler and / or dock bumper blocks (bumpers blocks are not structural).

**OPERATING INSTRUCTIONS**  
Only for the V-Dock Vertical Storing Dock Leveler with Blue Genius™ Touch Control

	<p><b>DEPLOYING THE DOCK LEVELER</b></p> <ol style="list-style-type: none"> <li>1. Touch and hold the <b>'DOWN'</b> button. The menu screen will read 'Deck Lowering.' The control station light is RED and the exterior traffic light (if equipped) turns from GREEN to RED. If performing Below Level End Loading, begin step C now.</li> <li>2. Continue holding the <b>'DOWN'</b> button until the lip makes full contact with truck bed. Release the button. The menu screen will read 'Deck Deployed.' The control station light will turn GREEN when in working range while the exterior traffic light remains RED.</li> <li>3. Loading/unloading may now begin. Ensure that the full width of the lip overlaps the truck bed a minimum of 4" (102 mm) for full support.</li> </ol>
	<p><b>RETURNING THE DOCK LEVELER TO HOME POSITION</b></p> <ol style="list-style-type: none"> <li>1. To return the dock leveler to the home position, hold the <b>'DECK'</b> button until the deck and lip are fully raised (home position). The menu screen will read 'Deck Raising.' The control station light changes to RED and the exterior traffic light remains RED. When the dock has reached the home position, the exterior traffic light turns GREEN.</li> </ol>
	<p><b>BELOW LEVEL / END LOADING</b></p> <ol style="list-style-type: none"> <li>1. After completing Step A (1), touch and hold the <b>'LIP'</b> button. The menu screen will read 'Lip Lowering.' The control station light is RED, the exterior traffic light remains RED. Release the <b>'LIP'</b> button when the lip reaches pendant position.</li> </ol>
	<p><b>STOP BUTTON FUNCTION</b></p> <ol style="list-style-type: none"> <li>1. Touching the <b>'STOP'</b> button during dock operation will cause the unit to stop in mid motion while the initial alarm will beep until the stop function is exited. The control station light will flash RED and the exterior traffic light will be RED. To exit the 'STOP' mode, touch <b>'ESC'</b> button.</li> </ol>

DANGER

1. Only trained and authorized personnel may operate this dock leveler.
2. Read, understand, and follow the instructions on this document.
3. Prior to using the dock leveler:
  - Ensure that the dock leveler is free and clear of all debris, snow and ice.
  - Ensure that all personnel near the dock leveler are aware that it is being operated.
  - Operate the dock leveler through one complete cycle to confirm that it is functioning properly. If the dock leveler is equipped with a communications package, confirm that the lights are working as required.
  - Inspect unit for signs of structural damage or mechanical malfunction. If damage is observed or the restraint fails to operate properly, remove it from service and notify maintenance personnel immediately.
4. When using the dock leveler:
  - Confirm that the transport vehicle has been properly restrained.
  - Keep hands and feet clear of pinch points.
  - If the dock leveler is equipped with a light communication package, load and unload on green only.
  - Do not exceed the rated capacity as indicated on the serial plate.
  - Do not leave equipment or material unattended on the dock leveler.
  - Keep a safe distance from both edges.
  - If dock leveler fails to operate as outlined in the accompanying manual's operating instructions, refer to the Troubleshooting section.
5. If service or maintenance is required:
  - Only authorized service personnel shall maintain or service the unit.

**APPLIES TO ALL DOCK LEVELERS**  
 BLUE GENIUS™ www.BlueGenius.com 038-1123E

Vertical Dock operation placard—part # 038-1123E.

**8.1 FUNCTIONAL DESCRIPTION**

The dock leveler is stored in the vertical position behind the overhead door, allowing for a complete energy efficient seal. The vertical storing dock includes a "controlled lowering" hydraulic system, meaning that the dock attendant must hold the touch button to lower the unit. Key features include: high tensile steel, J-beam deck construction, hydraulic fall-safe, maintenance strut and a self-locking device.

<div style="border: 1px solid black; padding: 5px; width: fit-content; margin: 0 auto;">EXTERIOR TRAFFIC LIGHT (OPTIONAL)</div> <p>Exterior red / green traffic lights advise the truck driver when it is safe to depart.</p>	<div style="border: 1px solid black; padding: 5px; width: fit-content; margin: 0 auto;">INSIDE COMMUNICATION LIGHTS &amp; CONTROL PANEL</div> <p>Red / yellow / green control station lights keep forklift operators and warehouse personnel advised of safety conditions at the loading dock.</p>
---	--

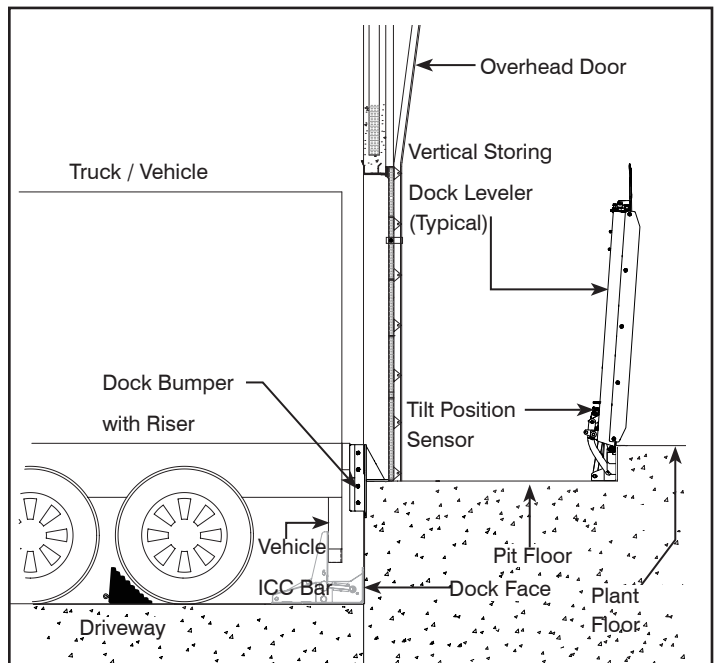

## ADVANCED SAFETY FEATURES

### ⚠️ WARNING

Verify visually on the Blue Genius Control Panel and around the dock area that all doors (facility, trailer, or vehicle), paths, and interlocks (if present) required for load transfer are fully open, unobstructed, and functioning BEFORE operating the dock leveler.  
For more information see Section 8.0 Operating Instructions on page 13.

#### 8.2 STOP BUTTON FUNCTION

Should an unexpected interference occur or potentially dangerous situation arise, the Blue Genius™ control panel has a temporary 'STOP' button. Touching the 'STOP' button during operation will cause the unit to stop in mid motion and the internal alarm will beep until the stop function is exited. The control panel light will flash RED and the exterior traffic light will be RED. To exit the 'STOP' mode touch the 'ESC' button.

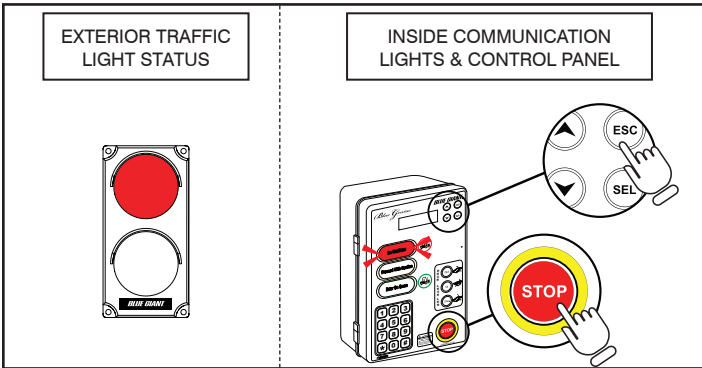
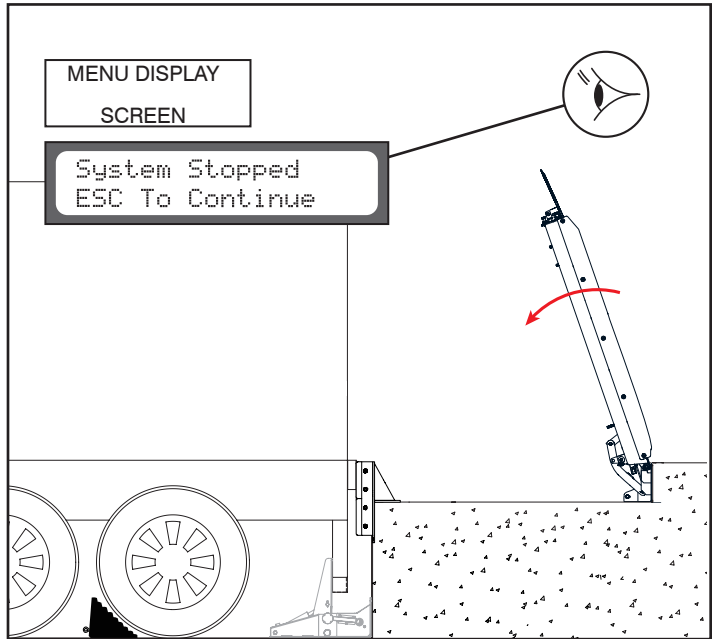

## STANDARD OPERATION PROCEDURES

### ⚠️ WARNING

Verify visually on the Blue Genius Control Panel and around the dock area that all doors (facility, trailer, or vehicle), paths, and interlocks (if present) required for load transfer are fully open, unobstructed, and functioning BEFORE operating the dock leveler.  
For more information see Section 8.0 Operating Instructions on page 13.

#### 8.3 STARTING PROCEDURE

The operating instructions in this manual include references to the advanced communication lights package (control panel and traffic lights.) This is an optional feature and may not be included with your dock leveler.

The truck reverses into position against the dock leveler bumpers. Exterior traffic light is GREEN and control panel light remains RED.

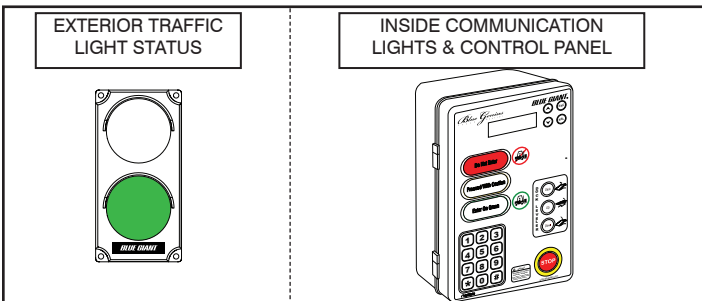
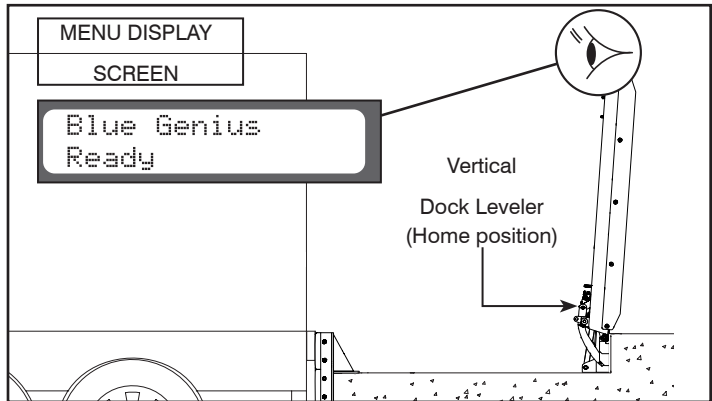

**WARNING**

Verify visually on the Blue Genius Control Panel and around the dock area that all doors (facility, trailer, or vehicle), paths, and interlocks (if present) required for load transfer are fully open, unobstructed, and functioning BEFORE operating the dock leveler. For more information see Section 8.0 Operating Instructions on page 13.

**8.4 DEPLOYING THE DOCK LEVELER**

After verifying that the vehicle is properly restrained, touch and hold the 'Down' button until the leveler reaches its operating range and then it will begin to fall by itself. If the deck needs to be stopped during its descent, touch the STOP button. The menu screen will read 'Deck Lowering'. Both the control panel and exterior traffic light are RED.

**NOTE:** If deployment is paused mid-cycle, the audible alarm will sound.

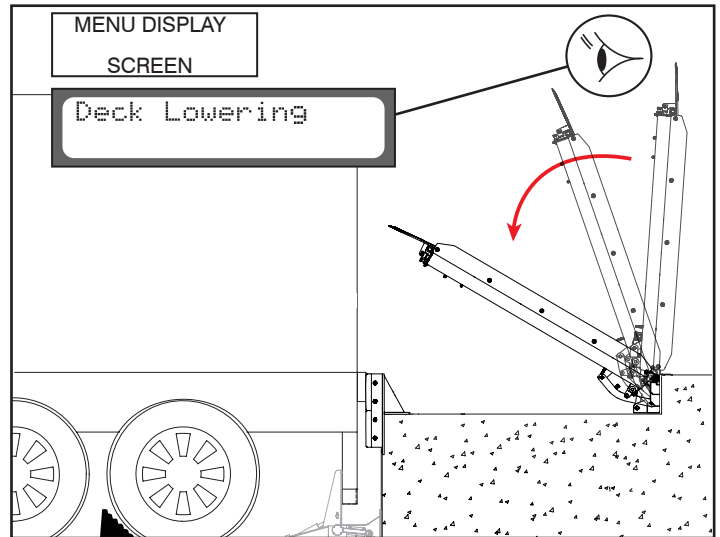
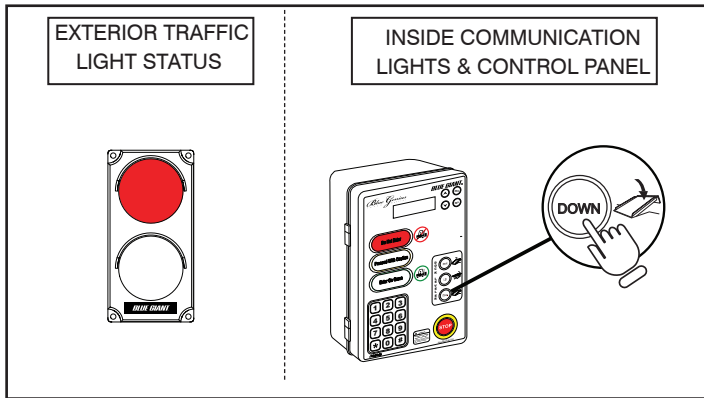

**WARNING**

Verify visually on the Blue Genius Control Panel and around the dock area that all doors (facility, trailer, or vehicle), paths, and interlocks (if present) required for load transfer are fully open, unobstructed, and functioning BEFORE operating the dock leveler. For more information see Section 8.0 Operating Instructions on page 13.

**8.5 DEPLOYED ON TRAILER**

1. 1. When the deck is properly deployed, the exterior traffic light stays RED and the control panel light changes to GREEN, advising dock staff that the vehicle is now accessible. The menu screen will read 'Deck Deployed'.
2. 2. When deployed, ensure that all personnel and equipment is clear of the transport vehicle and the dock leveler.

**NOTE:** Ensure that the full width of the lip overlaps the truck a minimum of 4" (102 mm) to provide full dock leveler support.

**NOTE:** While in use, the dock leveler raises and lowers automatically in conjunction with the movement of the truck bed.

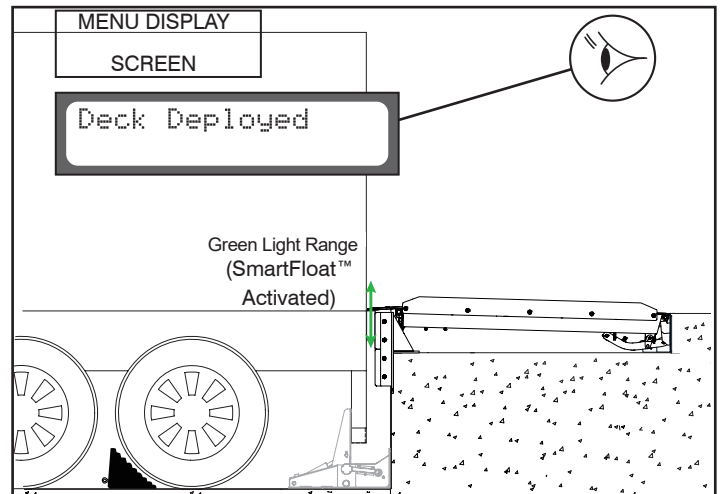
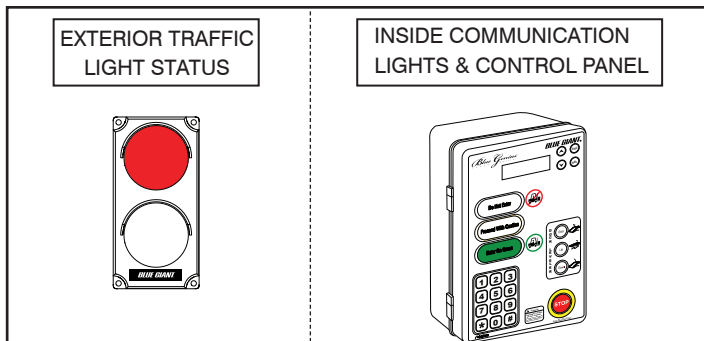

## PERFORM LOADING AND UNLOADING

### WARNING

Verify visually on the Blue Genius Control Panel and around the dock area that all doors (facility, trailer, or vehicle), paths, and interlocks (if present) required for load transfer are fully open, unobstructed, and functioning BEFORE operating the dock leveler. For more information see Section 8.0 Operating Instructions on page 13.

### 8.6 RETURNING DOCK LEVELER TO THE HOME POSITION

To return the dock leveler to home position, maintain pressure on the 'Deck' button until the deck and lip are fully raised. The menu screen will read 'Deck Raising'. The control panel light changes to RED and the exterior traffic light remains RED. When the dock has reached the home position, the exterior traffic light turns GREEN.

**NOTE:** If the lip is not completely extended, keep holding 'Deck' button and the controls will switch to lip function, extending the lip.

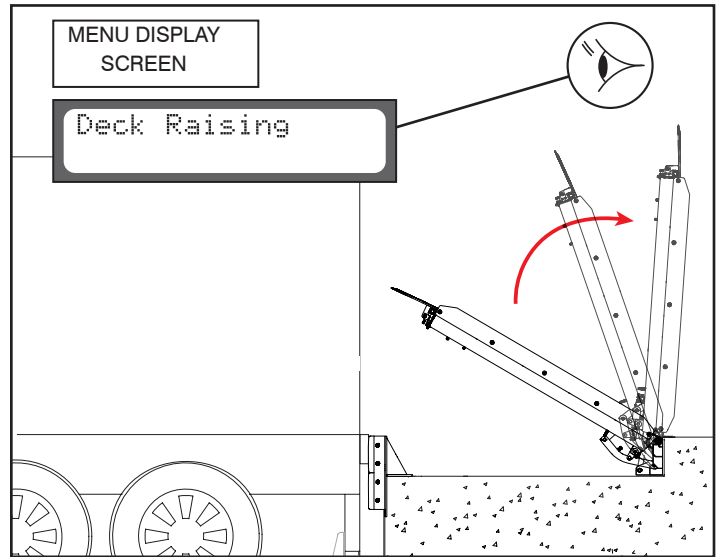
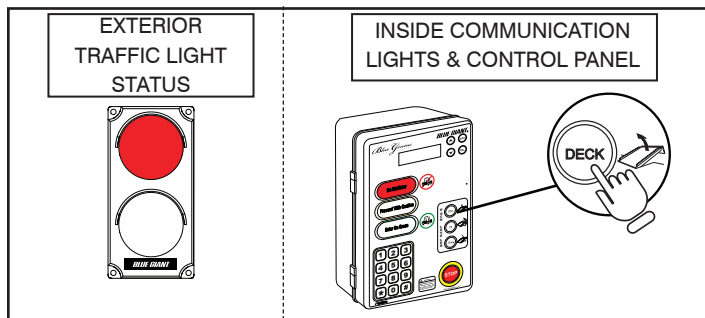

### WARNING

Verify visually on the Blue Genius Control Panel and around the dock area that all doors (facility, trailer, or vehicle), paths, and interlocks (if present) required for load transfer are fully open, unobstructed, and functioning BEFORE operating the dock leveler. For more information see Section 8.0 Operating Instructions on page 13.

### 8.7 DEPLOYING THE DOCK LEVELER: BELOW LEVEL / END LOADING

If the dock leveler lip cannot be successfully deployed onto the truck bed, please follow the steps below for below level / end loading.

1. Touch and hold the 'Down' button. The menu screen will read 'Deck Lowering'. When the deck is halfway down, release the 'Down' button. The menu screen will read 'Ready to Lower Deck'.

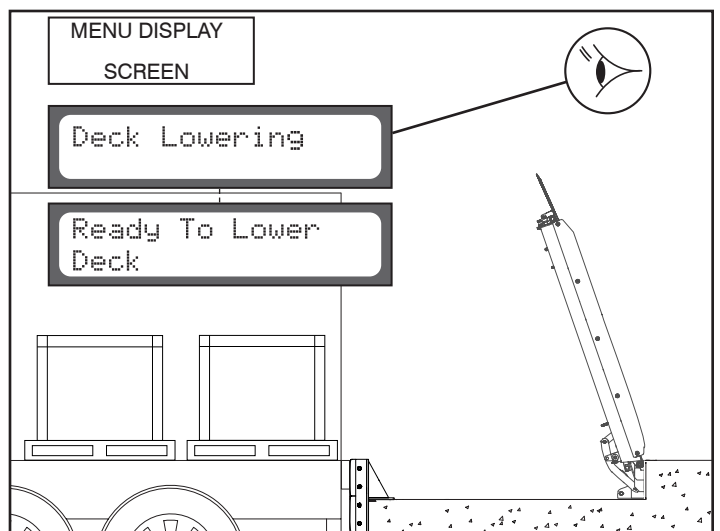
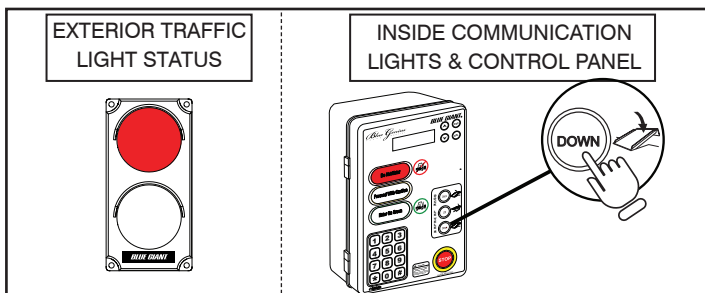

2. Touch and hold the 'Lip' button. The menu screen will read 'Lip Lowering'. The control panel light is RED, the exterior traffic light remains RED. Release the 'Lip' button when the lip reaches pendant position.

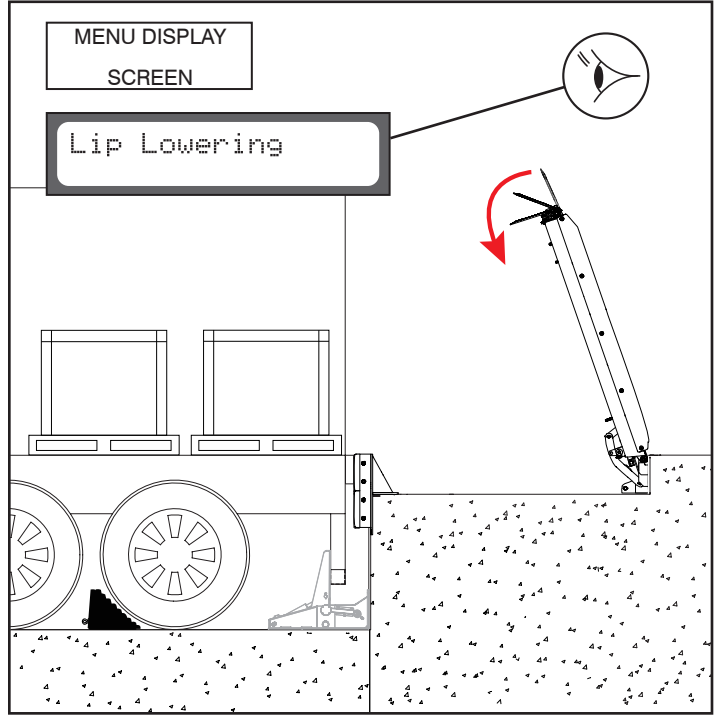
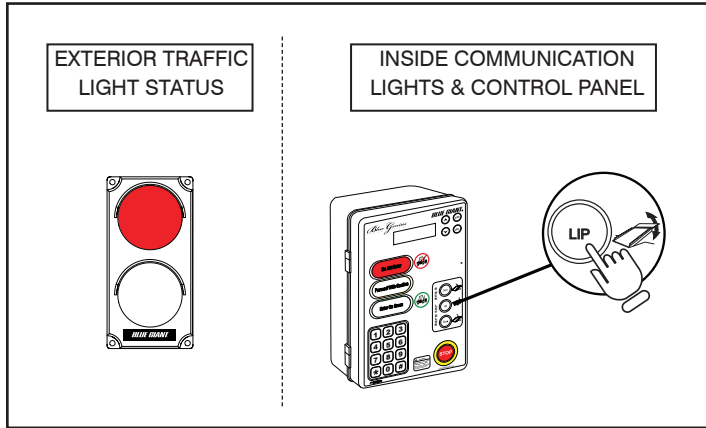

3. With the lip lowered, touch and hold the 'DOWN' button. The deck will lower to the below level working position. The menu screen will read 'Deck Lowering'. The control panel light changes to GREEN when the leveler is in the below level position and exterior traffic light remains RED. The menu screen will read 'Deck Deployed'.

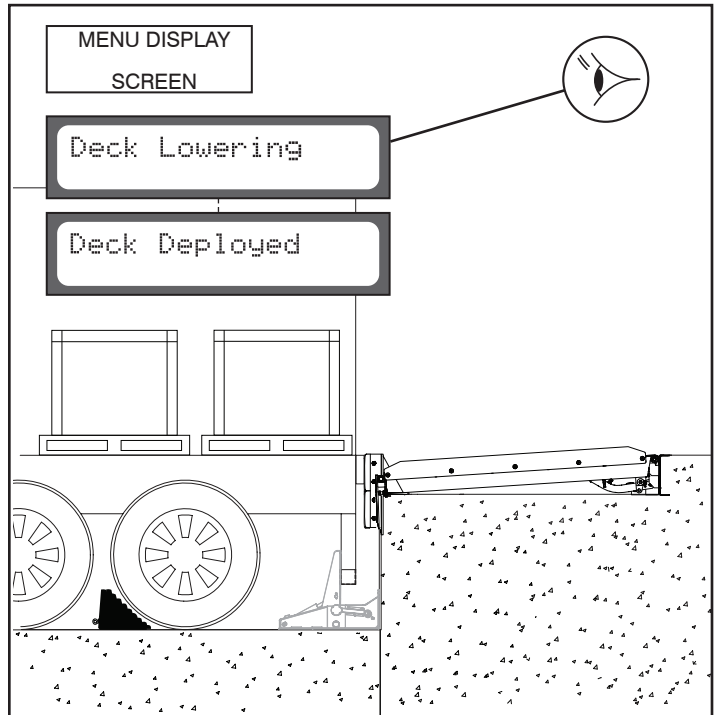
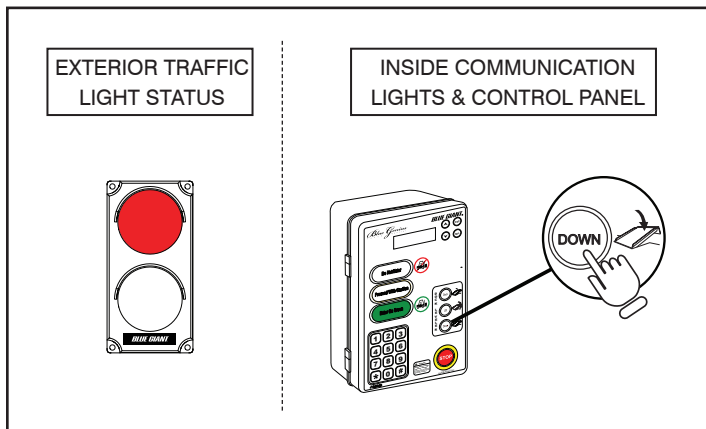

## 8.8 RETURNING TO NORMAL LIP-ON TRAILER OPERATION

### WARNING

The transport vehicle should never be allowed to depart with the lip plate resting on the load bed. Verify visually on the Blue Genius Control Panel and around the dock area that all doors (facility, trailer, or vehicle), paths, and interlocks (if present) required for load transfer are fully open, unobstructed, and functioning BEFORE operating the dock leveler. For more information see Section 8.0 Operating Instructions on page 13.

1. Touch and hold the 'Deck' button until the deck and the edge of the lip are raised above the top surface of the truck bed. The control panel light changes to RED, the exterior traffic light remains RED. The menu screen will read 'Deck Raising'.

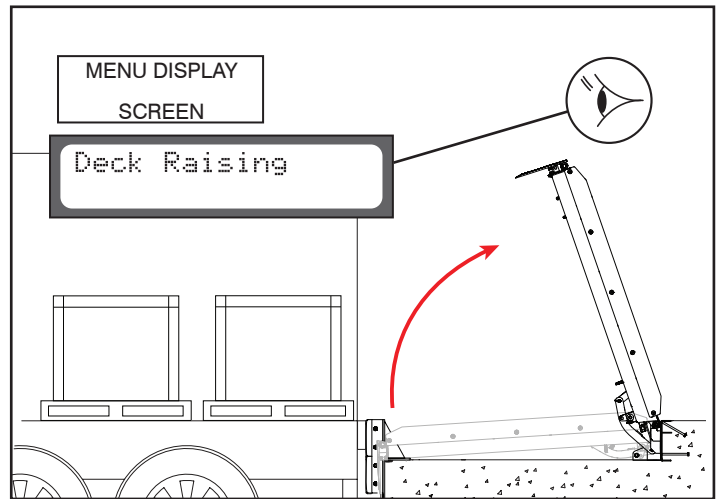
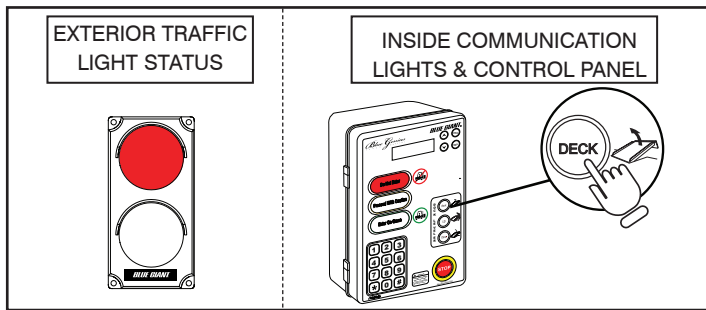

2. Release the 'Deck' button. Touch and hold the 'Lip' button until the lip is fully extended. The menu screen will read 'Lip Raising'. Release the 'Lip' button.
3. Release the 'Lip' button.

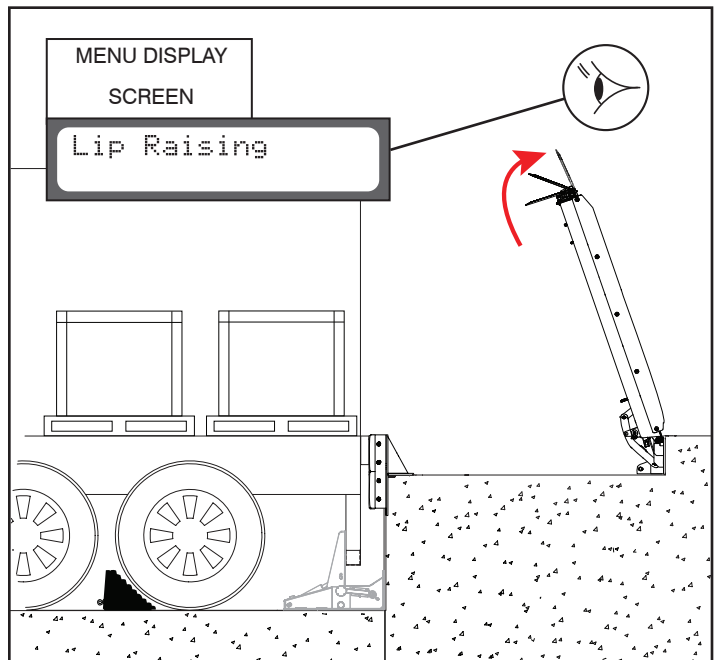
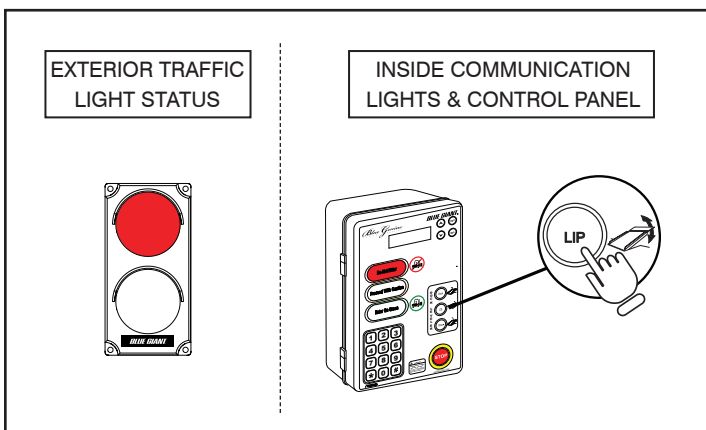

4. To continue, see Section 8.4 "Deploying the Dock Leveler" and 8.5 "Deployed on Trailer."

**9.0 OVERHEAD DOOR INTERLOCK**

**! WARNING**

Verify visually on the Blue Genius Control Panel and around the dock area that all doors (facility, trailer, or vehicle), paths, and interlocks (if present) required for load transfer are fully open, unobstructed, and functioning BEFORE operating the dock leveler. For more information see Section 8.0 Operating Instructions on page 13.

**9.1 OVERHEAD DOOR SENSOR (OPTIONAL)**

The overhead door sensor is optional with all hydraulic dock levelers. The function of the overhead door sensor is to protect the shipping / receiving door from accidental deployment of the dock leveler onto a closed or partly open door.

**9.1.1 OVERHEAD DOOR NOT FULLY OPEN**

If the door is not fully opened, the door sensor will not allow the Blue Genius™ control panel to operate the leveler. The control panel menu screen will read 'WARNING Door Not Open', the alarm (optional) will beep and the leveler will not move until the door has been opened past the door sensor range.

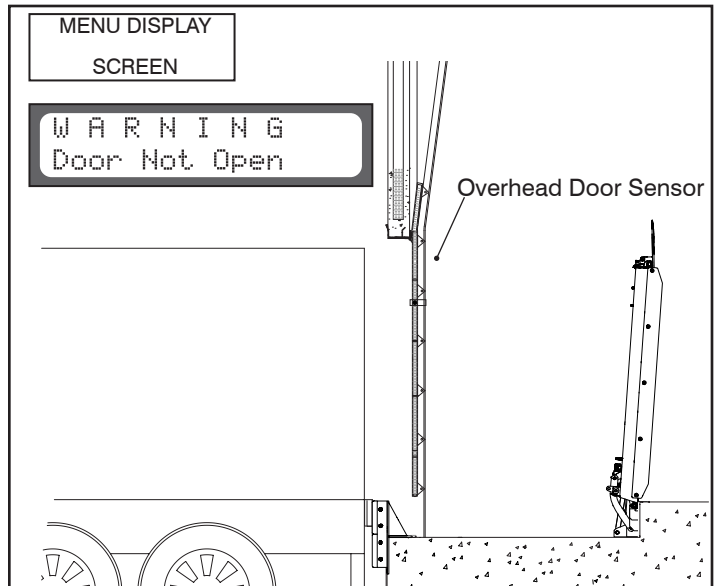

**9.1.2 OVERHEAD DOOR CLOSED DURING OPERATION**

If the door is closed while the dock is deploying, the door sensor will stop the dock leveler in position. The control panel menu screen will read 'WARNING Door Not Open' and the alarm will beep. Until the door has been opened past the door sensor, the leveler will not move.

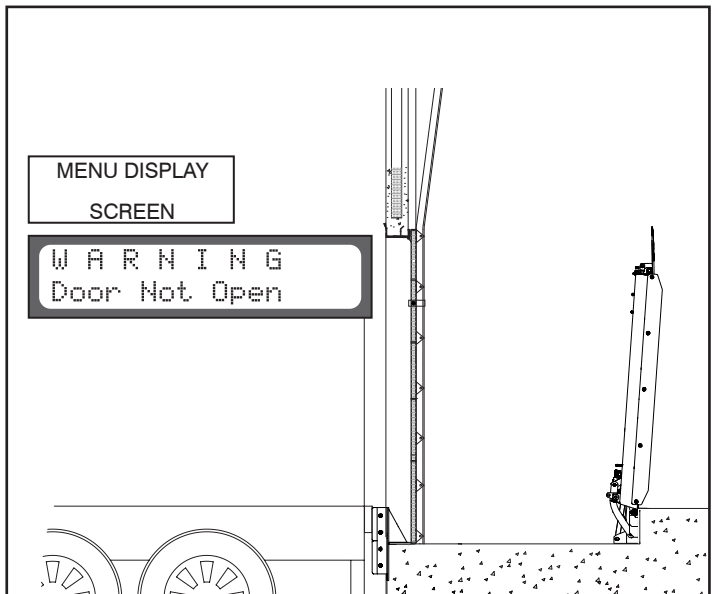



## WARNING

Verify visually on the Blue Genius Control Panel and around the dock area that all doors (facility, trailer, or vehicle), paths, and interlocks (if present) required for load transfer are fully open, unobstructed, and functioning BEFORE operating the dock leveler.

For more information see Section 8.0 Operating Instructions on page 13.

### 9.1.3 OVERHEAD DOOR CLOSED WHILE DOCK IS DEPLOYED

If the door is closed when the leveler is on the load bed or below level, the control station light will change from GREEN to RED and the alarm will beep. Until the door has been opened past the door sensor range, the leveler will not move.

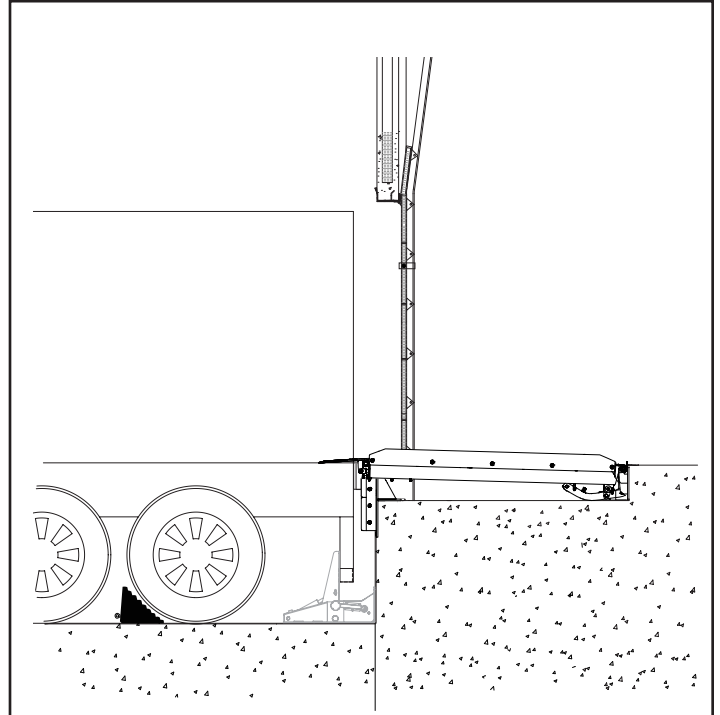

10.0 RECOMMENDED SPARE PARTS

10.1 STANDARD OPERATIONAL COMPONENTS

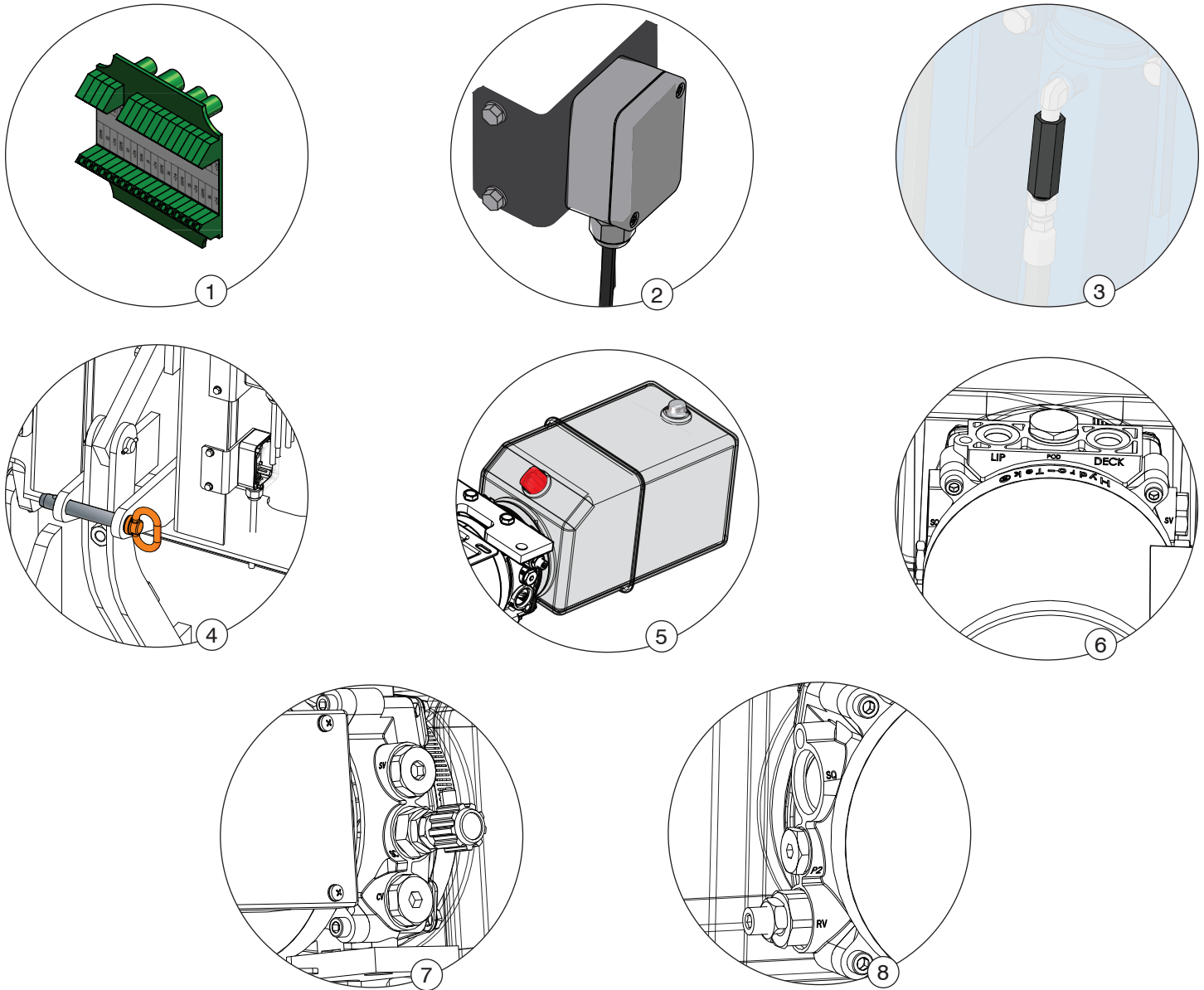

RSP FOR DOCK – STD OPERATIONAL COMPONENTS

ITEM	PART NO.	DESCRIPTION	QTY REQ'D
1	026-G025BM	Remote I/O Board (No Resistor)	1
2	026-G024-A	IntelliTilt™ Sensor Assembly	1
3	033-661	Velocity Fuse	1
4	013-077	Safety Stand Lock Pin w/ Ball Plunger	1
5	080-510	Reservoir Kit - Vertical Dock Powerpack	1
6	—	Lip (T Line) and Deck (P Line) Hydraulic Lines	1

RSP FOR DOCK – STD OPERATIONAL COMPONENTS

ITEM	PART NO.	DESCRIPTION	QTY REQ'D
7	—	SV	—
		CV	
		SC	
8	—	SQ	—
		P2	
		RV	

10.1 STANDARD OPERATIONAL COMPONENTS CONT'D.

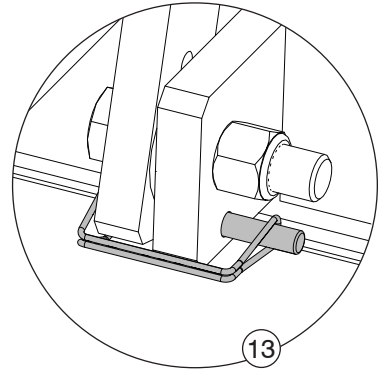
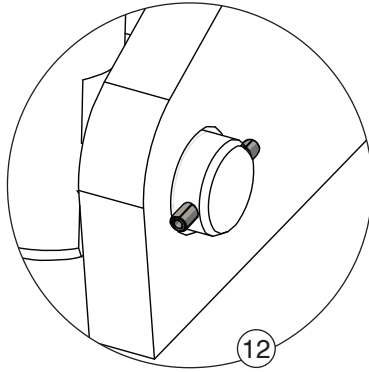
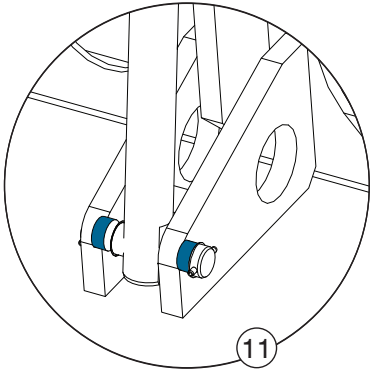

RSP FOR DOCK – STD OPERATIONAL COMPONENTS

ITEM	PART NO.	DESCRIPTION	QTY REQ'D
11	018-121	Bushings	2
12	013-127	3/16" Dia. Spring Pin x 1.50	8
13	013-078	Linch Pin 3/8" Dia. x 2-1/4" Usable	1

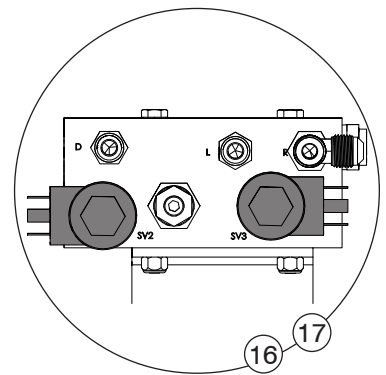
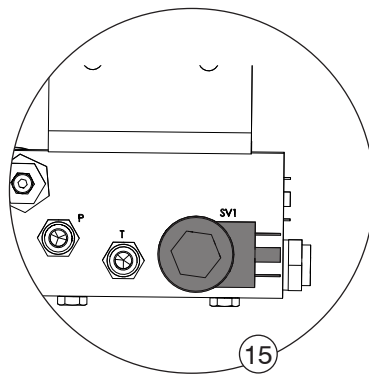
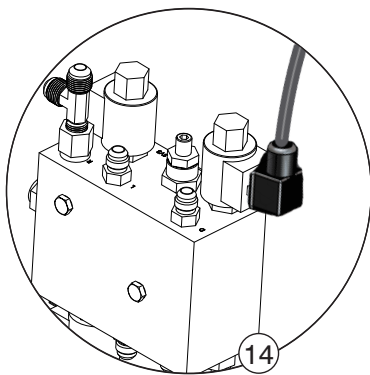

RSP FOR Dock – STD OPERATIONAL COMPONENTS

ITEM	PART NO.	DESCRIPTION	QTY REQ'D
14	026-G074	Solenoid Valve Connector with Cable	1
15	Please contact your Blue Giant Dealer.	SV1 Kit	1
16		SV2 Kit	1
17		SV3 Kit	1

**10.2 OPTIONAL SUPPORT COMPONENTS**

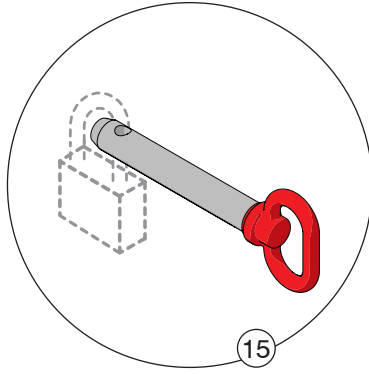
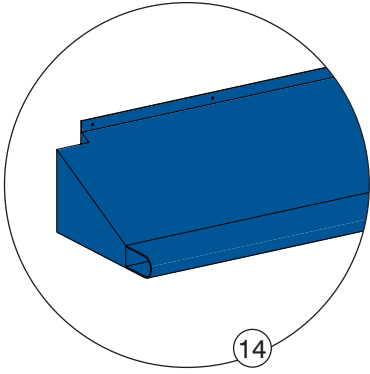

**RSP FOR Vertical Dock (OPTIONAL)**

ITEM	PART NO.	DESCRIPTION	QTY REQ'D
14	2014527-1	Draft Pad (72" Door Width)	1
	2014527-2	Draft Pad (78" Door Width)	
	2014527-3	Draft Pad (83" Door Width)	
15	013-092	Lock-out/Tag-out Safety Stand Pin	1



## 12.0 EQUIPMENT COMPONENT ILLUSTRATIONS

### 12.1 COMPONENTS AS SHIPPED CHECKLIST

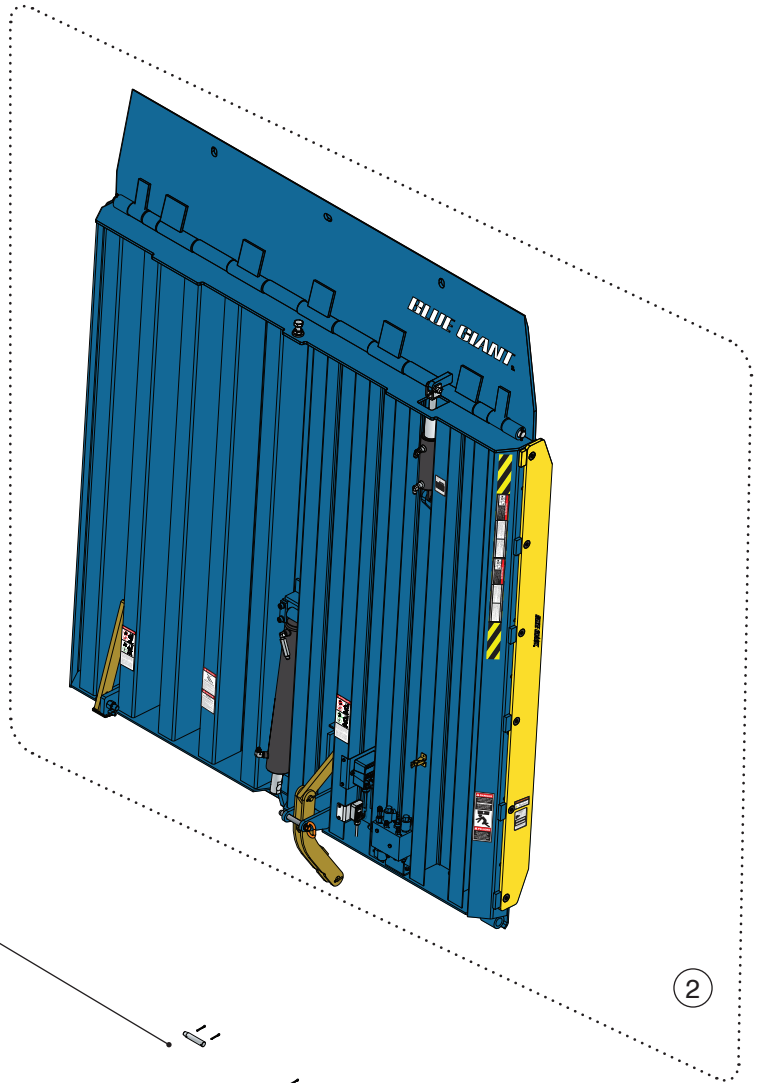

Remove plug after installation.  
Replace with breather cap  
(See Section 13.6 for more details).

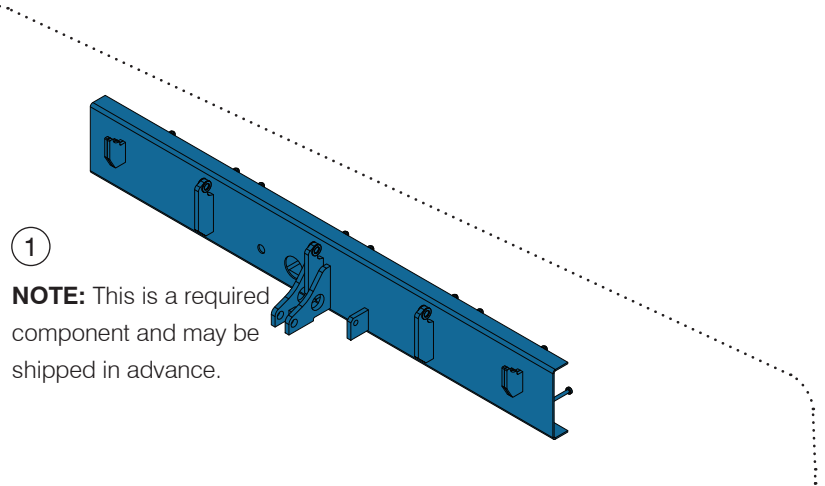
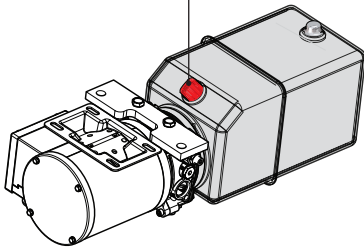

**NOTE:** This is a required component and may be shipped in advance.

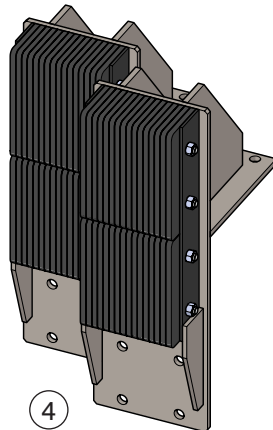

**NOTE:** Tank should be 3/4 full of hydraulic fluid when dock parked.

**12.1 COMPONENTS AS SHIPPED CHECKLIST CONT'D.**

✓	ITEM	QTY	PART NO.	DESCRIPTION	APPROX. WEIGHT	
	1	1	FRAME- _V- _ - _	Back Frame (See Section 13.3 for Sizes)	150 - 193 lb	68 - 87 kg
	1	1	FRAME- _V- _ - _-WO	Weld-on Back Frame (See Section 13.3 for Sizes)	115 - 157 lb	52 - 72 kg
	2	1	—	Deck and Lip Assembly with Cylinder and Hoses	1030 - 2010 lb	467 - 412 kg
	3	1	—	Powerpack (See Section 13.6 for Voltages)	34 lb	15 kg
	4	2	DB412WR12	Laminated Bumper with Bracket	180 lb	82 kg
	5	1	013-077	Lock Pin	1 lb	0.45 kg

**ITEM # 6 - HARDWARE INCLUDED:**

✓	QTY	PART NO.	DESCRIPTION	APPROX. WEIGHT	
	3	2013770	Pivot Pin	< .5 lb	< .22 kg
	5		Pivot Pin(Extreme Capacity Only)		
	1	See Sec. 13.2	Shaft	22 - 26 lb	10 - 11.8 kg
	1	2013770	Cylinder Pin, Rod	< .5 lb	< .22 kg
	12	013-127	3/16 dia. Spring Pin x 1.50	—	—
	2	012-250	Flat Washers (U.S.) 1"	—	—

**ITEM # 7 - CONTROL AND COMPONENTS INCLUDED:**

✓	QTY	PART NO.	DESCRIPTION	APPROX. WEIGHT	
	1	BGG0V_F See Sec. 13.8	Complete Control Assembly English / French	6.2 lb	2.81 kg
		BGG0V_S See Sec. 13.8	Complete Control Assembly English / Spanish		
	1	038-1123	E	Operation Placard	—
			F		
			S		
	1	038-1121E	Vertical Dock Owner's Manual	—	—
	1	038-1121EI	Vertical Dock Installation Manual	—	—
	1	038-1121EPL	Vertical Dock Parts List	—	—
	1	032-806	Exterior Traffic Light - Optional	1.3 lb	0.6 kg

13.0 MECHANICAL ASSEMBLY

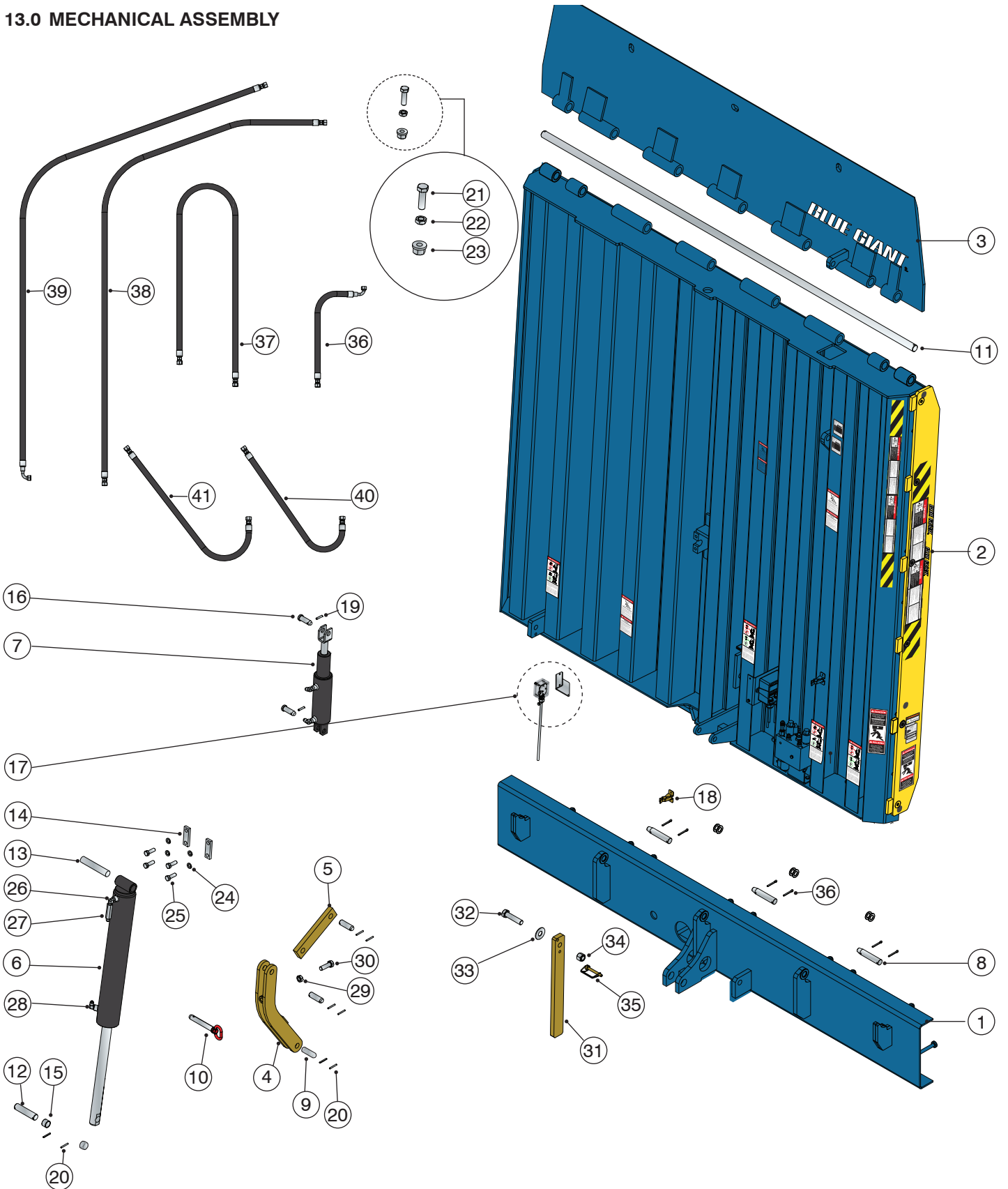

**13.0 MECHANICAL ASSEMBLY CONT'D.**

ITEM	QTY	PART NO.	DESCRIPTION
1	1	See Sec. 13.3	Back Frame Weldment
2	1	See Sec. 13.1	Deck Weld
3	1	See Sec. 13.2	Lip Plate Weldment
4	1	1000847-1	Service Stand
5	1	1000839	Service Stand - Top Link
6	1	23-014490-3	Deck Cylinder Assembly - 2" Cushion
7	1	213-5058-1	Lip Cylinder Assembly, Double Acting
8	3	2013770	Pivot Pin
	5		Pivot Pin (Extreme Capacity Only)
9	3	23-012803-1	Pivot Pin
10	1	013-077	Lock Pin
11	1	See Sec. 13.2	Shaft
12	1	23-012717-1	Cylinder Pin Rod
13	1	090-189-0054	Pin
14	2	23-003568	Clevis Plate
15	2	018-121	Bushing
16	2	107-196	Clevis Pin
17	1	23-013313	Inclinometer Assembly
	1		Bracket
	2	011-159	Self-tapping Screws 1/4"
18	1	013-537	Tool Holder - Zinc Plated - 5/8" - 7/8" dia.

ITEM	QTY	PART NO.	DESCRIPTION
19	2	013-010	1/4" dia. Spring Pin 1.25" long
20	14	013-127	3/16" dia. Spring Pin x 1.50" long
21	2	010-060	HHCS 5/16-18 UNC x 1 GR.5 ZN
22	2	012-200	Regular Spring Lock Washers 5/16" (U.S.)
23	2	011-530	Hex Nuts (U.S.)
24	4	012-220	Regular Spring Lock Washers (U.S.)
25	4	011-075	HHCS 1/2-13 UNC x 1-1/2"
26	1	034-515	Fitting 4MP-4MP-90
27	1	033-661	Velocity Fuse
28	1	034-601	Adaptor 90 Deg Fitting
29	1	011-527	Hex Jam Nut
30	1	010-066	Screw Cap HHCS 5/8-11, GR.5
31	1	2015275-1	Maintenance Strut for 12" Pit
		2015275-2	Maintenance Strut for 15" Pit
32	1	010-086	Screw Shoulder 3/4 x 1-3/4" long
33	1	012-214	Flat Washers (U.S.) 3/4"
34	1	011-535	Flange Hex. Locknut 3/4" - 10
35	1	013-078	Linch Pin - 3/8" dia. x 2-1/4" Usable
36	6	013-025	Cotter Pin, 3/15x1 1/2
	10		Cotter Pin, 3/15x1 1/2 (Extreme Capacity Only)

		HOSE ASSY. - #6 HIGH PRESSURE		RUN TO WALL - 18' (5.5m)		RUN TO POST - 9' (2.7m)	
ITEM	DECK LENGTH	DESCRIPTION		PART NO.	ACTUAL SIZE	PART NO.	ACTUAL SIZE
36	6' (1.8m)	Deck	Raise	300-5005-7	35" L	300-5005-7	35" L
37			Lower	300-5000-49	56" L	300-5000-49	56" L
38		Lip	Extend	300-5000-19	30" L	300-5000-19	30" L
39			Return	300-5005-7	35" L	300-5005-7	35" L
40	Self-Contained Powerpack Only	Powerpack T (Tank) Line		2016140		2016140	
41		Powerpack P (Power) Line		300-5005-16		300-5005-16	
36	8' (2.4m)	Deck	Raise	300-5005-7	35" L	300-5005-7	35" L
37			Lower	300-5000-49	56" L	300-5000-49	56" L
38		Lip	Extend	300-5000-49	56" L	300-5000-49	56" L
39			Return	300-5005-9	59" L	300-5005-9	59" L
40	Self-Contained Powerpack Only	Powerpack T (Tank) Line		300-5000-15	26" L	300-5000-15	26" L
41		Powerpack P (Power) Line		300-5000-18	29" L	300-5000-18	29" L

Run = Backframe to powerpack

**13.1 VERTICAL DOCK DECK SIZE AND CAPACITIES**

See Sec. 13.0 - Item 2

DECK SIZE (NOMINAL)	CAPACITY	MODEL	PART NO.
6' x 6'	HEAVY	V6006H	DECK-H-V-STD-72W-57L
			DECK-H-V-SC-72W-57L
	SUPER	V6006S	DECK-S-V-STD-72W-57L
			DECK-S-V-SC-72W-57L
	EXTREME	V6006E	DECK-E-V-STD-72W-57L
			DECK-E-V-SC-72W-57L
6' x 8'	HEAVY	V6008H	DECK-H-V-STD-72W-81L
			DECK-H-V-SC-72W-81L
	SUPER	V6008S	DECK-S-V-STD-72W-81L
			DECK-S-V-SC-72W-81L
	EXTREME	V6008E	DECK-E-V-STD-72W-81L
			DECK-E-V-SC-72W-81L
6' 6" x 6'	HEAVY	V6606H	DECK-H-V-STD-78W-57L
			DECK-H-V-SC-78W-57L
	SUPER	V6606S	DECK-S-V-STD-78W-57L
			DECK-S-V-SC-78W-57L
	EXTREME	V6606E	DECK-E-V-STD-78W-57L
			DECK-E-V-SC-78W-57L

DECK SIZE (NOMINAL)	CAPACITY	MODEL	PART NO.
6' 6" x 8'	HEAVY	V6608H	DECK-H-V-STD-78W-81L
			DECK-H-V-SC-78W-81L
	SUPER	V6608S	DECK-S-V-STD-78W-81L
			DECK-S-V-SC-78W-81L
	EXTREME	V6608E	DECK-E-V-STD-78W-81L
			DECK-E-V-SC-78W-81L
7' x 6'	HEAVY	V7006H	DECK-H-V-STD-83W-57L
			DECK-H-V-SC-83W-57L
	SUPER	V7006S	DECK-S-V-STD-83W-57L
			DECK-S-V-SC-83W-57L
	EXTREME	V7006E	DECK-E-V-STD-83W-57L
			DECK-E-V-SC-83W-57L
7' x 8'	HEAVY	V7008H	DECK-H-V-STD-83W-81L
			DECK-H-V-SC-83W-81L
	SUPER	V7008S	DECK-S-V-STD-83W-81L
			DECK-S-V-SC-83W-81L
	EXTREME	V7008E	DECK-E-V-STD-83W-81L
			DECK-E-V-SC-83W-81L

**13.2 VERTICAL DOCK LIP SIZE AND CAPACITIES**

See Sec. 13.0 - Item 3 (Lip) and Item 11 (Shaft)

DECK WIDTH	CAPACITY	LENGTH		LIP PART NO.	SHAFT PART NO.
6'	HEAVY	18"	457mm	LIP-H-H-STD-FW-72W-18L	2000456-00
		20"	508mm	LIP-H-H-STD-FW-72W-20L	
	SUPER	18"	457mm	LIP-S-H-STD-FW-72W-18L	2000456-03
		20"	508mm	LIP-S-H-STD-FW-72W-20L	
	EXTREME	18"	457mm	LIP-E-H-STD-FW-72W-18L	
		20"	508mm	LIP-E-H-STD-FW-72W-20L	
6' 6"	HEAVY	18"	457mm	LIP-H-H-STD-FW-78W-18L	2000456-01
		20"	508mm	LIP-H-H-STD-FW-78W-20L	
	SUPER	18"	457mm	LIP-S-H-STD-FW-78W-18L	2000456-04
		20"	508mm	LIP-S-H-STD-FW-78W-20L	
	EXTREME	18"	457mm	LIP-E-H-STD-FW-78W-18L	
		20"	508mm	LIP-E-H-STD-FW-78W-20L	
7'	HEAVY	18"	457mm	LIP-H-H-STD-TP-83W-18L	2000456-02
		20"	508mm	LIP-H-H-STD-TP-83W-20L	
	SUPER	18"	457mm	LIP-S-H-STD-TP-83W-18L	2000456-05
		20"	508mm	LIP-S-H-STD-TP-83W-20L	
	EXTREME	18"	457mm	LIP-E-H-STD-TP-83W-18L	
		20"	508mm	LIP-E-H-STD-TP-83W-20L	

### 13.3 VERTICAL DOCK BACK FRAME SIZE

See Sec. 13.0 - Item 1

DECK SIZE (NOMINAL)	STANDARD DEPTH	PART NO.	OPTIONAL DEPTH	PART NO.
<b>6' Standard (1829mm)</b>	12" (305mm)	FRAME-WHS-V-72W-12D	15" (381mm)	FRAME-WHS-V-72W-15D
<b>6' 6" Standard (1981mm)</b>	12" (305mm)	FRAME-WHS-V-78W-12D	15" (381mm)	FRAME-WHS-V-78W-15D
<b>7' Standard (2133mm)</b>	12" (305mm)	FRAME-WHS-V-83W-12D	15" (381mm)	FRAME-WHS-V-83W-15D
<b>6' High (1829mm)</b>	12" (305mm)	FRAME-E-V-72W-12D	15" (381mm)	FRAME-E-V-72W-15D
<b>6' 6" High (1981mm)</b>	12" (305mm)	FRAME-E-V-78W-12D	15" (381mm)	FRAME-E-V-78W-15D
<b>7' High (2133mm)</b>	12" (305mm)	FRAME-E-V-83W-12D	15" (381mm)	FRAME-E-V-83W-15D
<b>6' Standard WELD-ON (1829mm)</b>	12" (305mm)	FRAME-WHS-V-72W-12D-WO	15" (381mm)	FRAME-WHS-V-72W-15D-WO
<b>6' 6" Standard WELD-ON (1981mm)</b>	12" (305mm)	FRAME-WHS-V-78W-12D-WO	15" (381mm)	FRAME-WHS-V-78W-15D-WO
<b>7' Standard WELD-ON (2133mm)</b>	12" (305mm)	FRAME-WHS-V-83W-12D-WO	15" (381mm)	FRAME-WHS-V-83W-15D-WO
<b>6' High WELD-ON (1829mm)</b>	12" (305mm)	FRAME-E-V-72W-12D-WO	15" (381mm)	FRAME-E-V-72W-15D-WO
<b>6' 6" High WELD-ON (1981mm)</b>	12" (305mm)	FRAME-E-V-78W-12D-WO	15" (381mm)	FRAME-E-V-78W-15D-WO
<b>7' High WELD-ON (2133mm)</b>	12" (305mm)	FRAME-E-V-83W-12D-WO	15" (381mm)	FRAME-E-V-83W-15D-WO

**13.4 PIT DIMENSIONS - T-STYLE PIT**

NOMINAL SIZE		PIT WIDTH (W)		PIT LENGTH (L)	
		in	mm	in	mm
6' x 6'	1829 x 1829mm	75	1905	57.5	1461
6' x 8'	1829 x 2438mm			81.5	2070
6' 6" x 6'	1981 x 1829mm	81	2057	57.5	1461
6' 6" x 8'	1981 x 2438mm			81.5	2070
7' x 6'	2108 x 1829mm	86	2184	57.5	1461
7' x 8'	2108 x 2438mm			81.5	2070
<b>Lip Length:</b>		18", 20" (457, 508mm)			
<b>Standard Pit Depth:</b>		Front (H): 12.5" (318mm)		Rear (H1): 12" (305mm)	
<b>Optional Pit Depth:</b>		Front (H): 15.5" (394mm)		Rear (H1): 15" (381mm)	

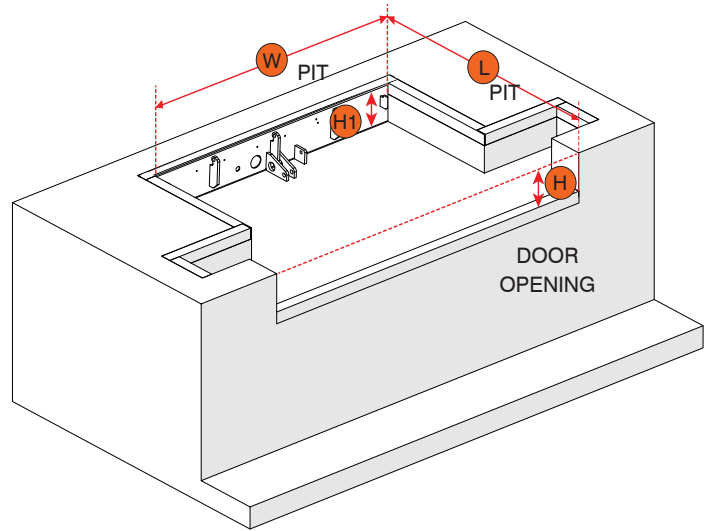

**13.5 PIT DIMENSIONS - CONTINUOUS PIT**

NOMINAL SIZE		FRAME WIDTH (W)		PIT LENGTH (L)	
		in	mm	in	mm
6' x 6'	1829 x 1829mm	81	2057	57.5	1461
6' x 8'	1829 x 2438mm			81.5	2070
6' 6" x 6'	1981 x 1829mm	87	2210	57.5	1461
6' 6" x 8'	1981 x 2438mm			81.5	2070
7' x 6'	2108 x 1829mm	92	2337	57.5	1461
7' x 8'	2108 x 2438mm			81.5	2070
<b>Lip Length:</b>		18", 20" (457, 508mm)			
<b>Standard Pit Depth:</b>		Front (H): 12.5" (318mm)		Rear (H1): 12" (305mm)	
<b>Optional Pit Depth:</b>		Front (H): 15.5" (394mm)		Rear (H1): 15" (381mm)	

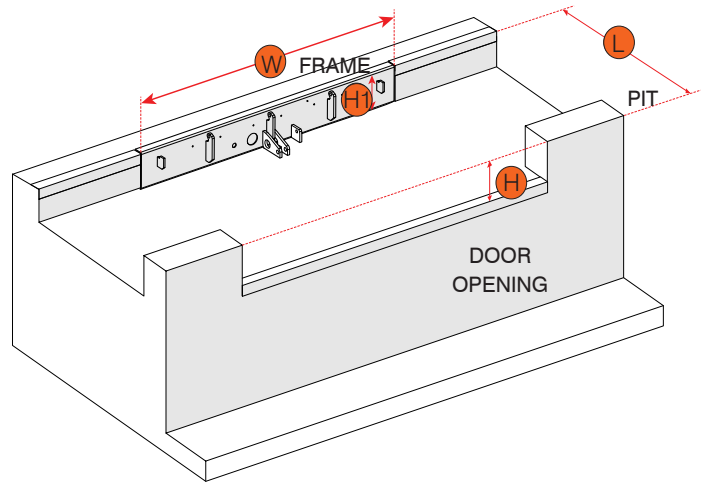

13.6 POWERPACK PART IDENTIFICATION

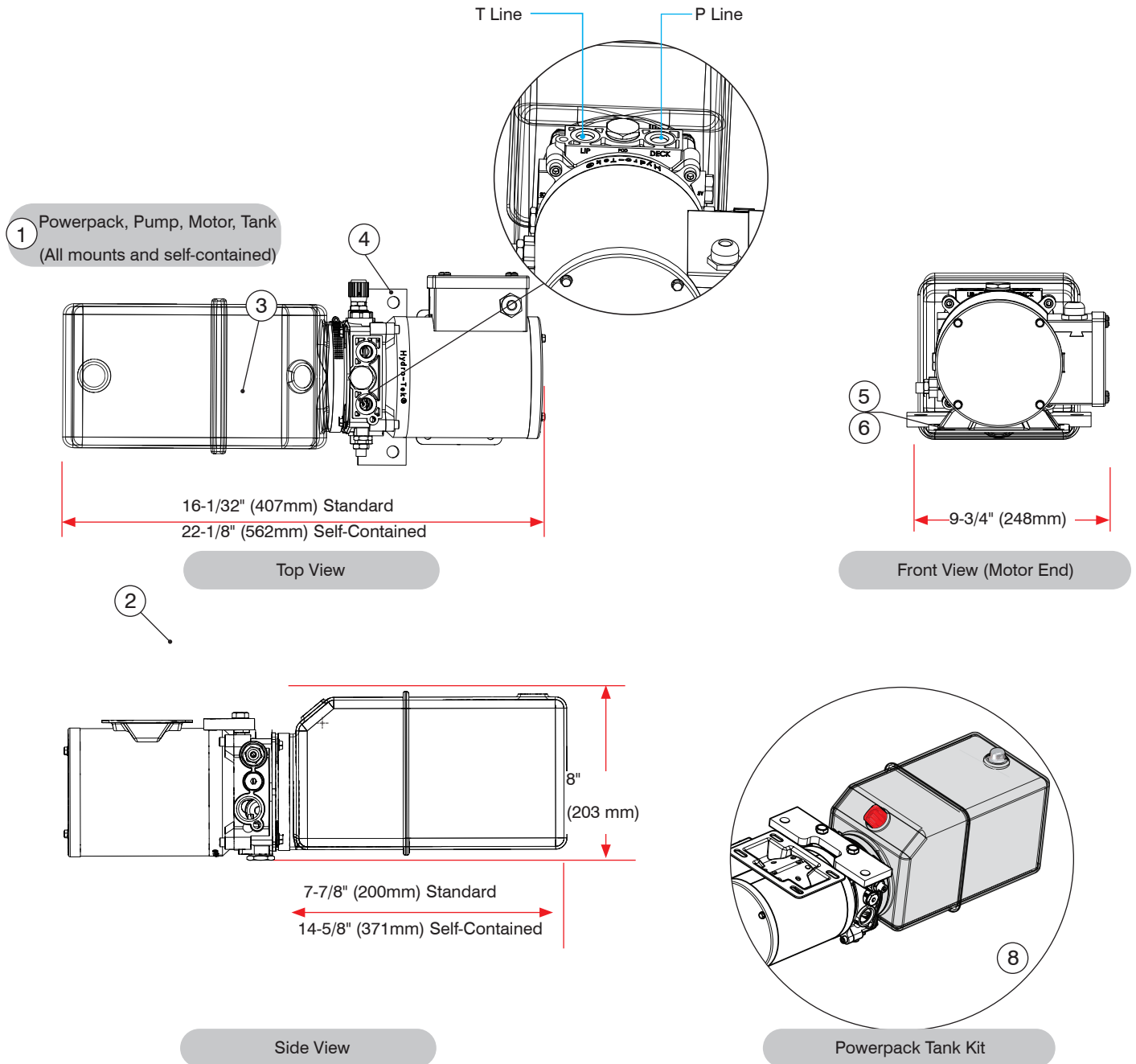

VERTICAL DOCK POWERPACK ASSEMBLY			
Standard Powerpack			
ITEM	QTY	PART NO.	DESCRIPTION
1	1	033-461-K	PPACK - REMOTE 1PH-115V-230V-60HZ
		033-462-K	PPACK - REMOTE 3PH-230/460V-60HZ
		033-463-K	PPACK REMOTE 3PH-575V-60HZ
5	—	OPT-V-DOCK- _OIL	Hydraulic Oil Options

VERTICAL DOCK POWERPACK ASSEMBLY			
Self-contained Powerpack Only (Self-Contained Powerpack = Standard + Kit)			
ITEM	QTY	PART NO.	DESCRIPTION
2	1	035-471	Tank
3	1	2014317	Wall Bracket (Self-Contained Only)
4	1	010-170	Hex Head Cap Screws M10x20
5	—	OPT-V-DOCK- _OIL	Hydraulic Oil Options

13.7 MANIFOLD PART IDENTIFICATION

1 Manifold

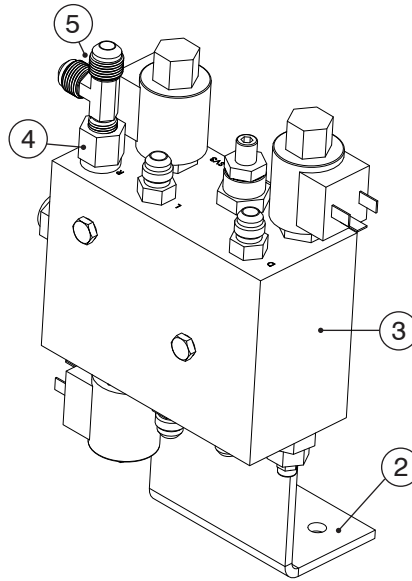

Bottom View

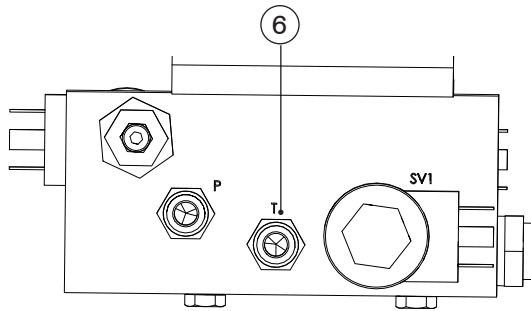

Top View

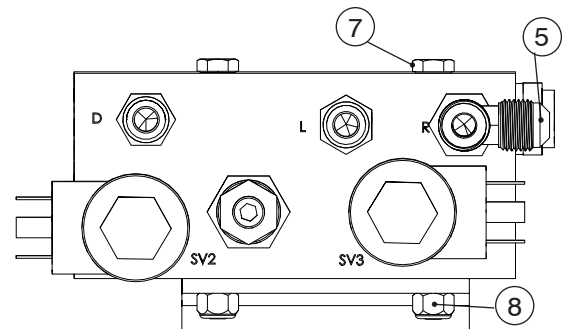

VERTICAL DOCK MANIFOLD ASSEMBLY # PART NUMBER			
ITEM	QTY	PART NO.	DESCRIPTION
1	1	2014215	Manifold Assembly
2	1	2013691	Manifold Mounting Bracket
3	1	2014213	Vertical Dock Manifold
4	1	034-508	3/6 Fem. Pipe to male O-ring
5	1	034-665	Fitting Tee #6
6	4	034-621	Staright #6 to O-ring #6
7	2	010-197	1/4-20x3x0.75, GR5, NP Screw Cap
8	2	011-545	Hex Nut Nylon Lock 1/4-20 Preferred

13.8 CONTROLS

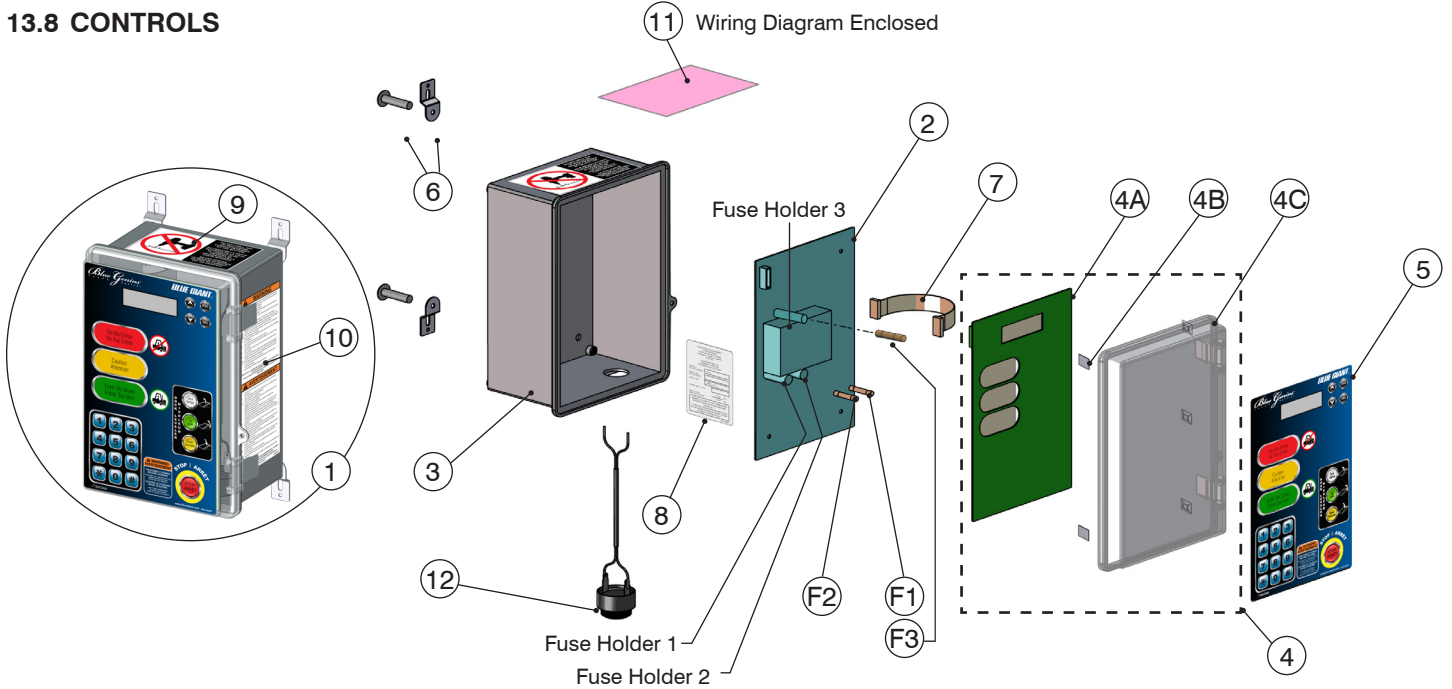

COMPLETE CONTROL STATION ASSEMBLY - ITEM 1 (Example BGG0V1115F)							ITEM	QTY	PART NO.	DESCRIPTION	
2	SINGLE PHASE						6	1	025-G010-1	Mounting Tabs with Hardware (1 pkg of 4)	
	◇	FUSE	QTY	PART NO.	DESCRIPTION	ASSY PART #	*	7	026-G030	Ribbon Cable	
	F1	A	1	026-PB1115-FH	Power Board Sub-Assembly † (1PH 115V 50-60HZ)	BGG0V1115	F	8	038-284E	F	Decal, Serial Plate
	F2	E	1				S			S	
	F1	C	1	026-PB1230	Power Board Sub-Assembly † (1PH 230V 50-60HZ)	BGG0V1230	F	9	038-283EFS	F	Decal, Do Not Drill
	F2	C	1				S			S	
	THREE PHASE						11	1	026-615-1	Anti-Static Poly Bag (Wiring Diagram Enclosed) (Serial # required for diagram)	
	◇	FUSE	QTY	PART NO.	DESCRIPTION	ASSY PART #	*	12	026-G028-B	Audible Speaker	
	F1	C	1	026-PB3230	Power Board Sub-Assembly † (3PH 230V 50-60HZ)	BGG0V3230	F	F3	026-037-1	F	AS PER VOLTAGE - SEE ITEM 1
	F2	C	1				S			S	
	F1	F	1	026-PB3400	Power Board Sub-Assembly † (3PH 400V 50-60HZ)	BGG0V3400	F	AS PER VOLTAGE - SEE ITEM 1			
	F2	F	1				S	ITEM QTY PART NO. DESCRIPTION			
	F1	G	1	026-PB3460	Power Board Sub-Assembly † (3PH 460V 50-60HZ)	BGG0V3460	F	A	1	026-G100	Fuse, 15A, 250V , Time Delay for 1PH, 110-130V
	F2	G	1				S	B	1	026-G101	Fuse, 8A, 250V, Time Delay for 1PH, 208-240V
F1	H	1	026-PB3575	Power Board Sub-Assembly † (3PH 575V 60HZ)	BGG0V3575	F	C	1	026-G102	Fuse, 0.5A, 250V, Time Delay for 1 and 3PH, 208-240V	
F2	H	1				S	D	1	026-G103	Fuse, 0.25A, 250V, Time Delay for 1PH, 208-240V	
3		1	025-G010-M	Control Box Enclosure (Includes 4C)			E	1	026-G104	Fuse, 0.75A, 250V, Time Delay for 1PH, 110-130V	
4		1	025-G014-V3-M	Transparent Cover Door (4C) and Touch Control Board (4A) (Serial # Required)			F	1	026-G105	Fuse, 500mA, 700V, Fast Acting for 3PH, 380-415V	
4A		1	026-G021-M	Touch Control Board (Serial # Required)			G	1	026-G106	Fuse, 400mA, 700V, Fast Acting for 3PH, 440-480V	
4B		5	025-062	Cable Tie Mount			H	1	026-G107	Fuse, 315mA, 700V, Fast Acting for 3PH, 575-600V	
4C		1	025-G014	Transparent Cover Door							
5		1	038-264E	Button Decal							

\* Language on decal: F = English / French S = English / Spanish

◇ Location on Power Board † Includes Fuses ‡ 115 Volt Control Box Shown

**13.9 STANDARD REMOTE I/O**

STANDARD REMOTE I/O PART # 026-H28			
ITEM	QTY	PART NO.	DESCRIPTION
1	1	025-G020-M	Junction Box 4" x 4"
2	2	025-174	PG16 Cable Gland
3	2	025-177	PG16 Metal Locknut
4	1	025-179	PG16 Multi-Hole Seal - 2 Holes
5	1	025-175	PG16 Multi-Hole Seal - 3 Holes
6	1	026-G025BM	Remote I/O Board (No Resistor)
7	1	038-279	Circuit Board Decal
8	3	026-G074	Solenoid Valve Connector - 5' (1.5 m)
9	1	026-H16-1	Communication Harness with cable - 30' (9.1 m)
10	1	026-H01-1	Communication Cable - 3 Wire - 20' (6 m)

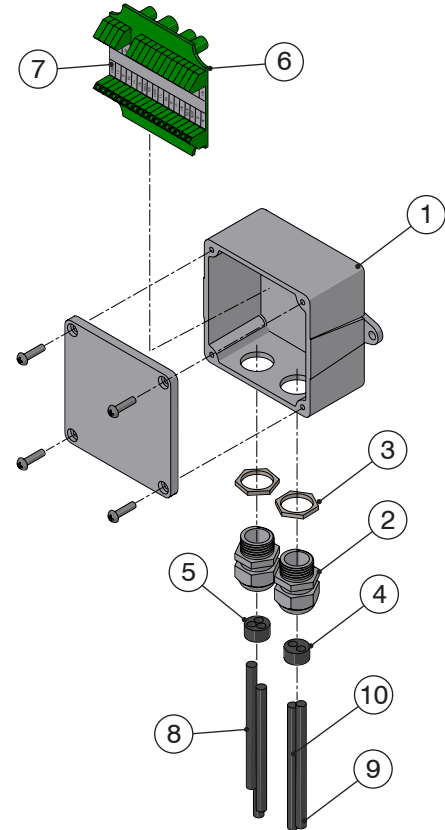

**13.10 OPTIONAL DOOR REMOTE I/O**

OPTIONAL DOOR REMOTE I/O PART # 70-0020			
ITEM	QTY	PART NO.	DESCRIPTION
1	1	110-404	Junction Box
2	1	026-G025-99	Remote I/O Board (Door Control)
3	1	025-173	PG9 Cable Gland
4	1	025-176	PG9 Metal Locknut
5	1	025-174	PG16 Cable Gland
6	1	025-177	PG16 Metal Locknut
7	1	025-175	PG16 Multi-Hole Seal - 3 holes
8	1	026-G031-C	Communication Cable Shielded - 15' (4.5 m)

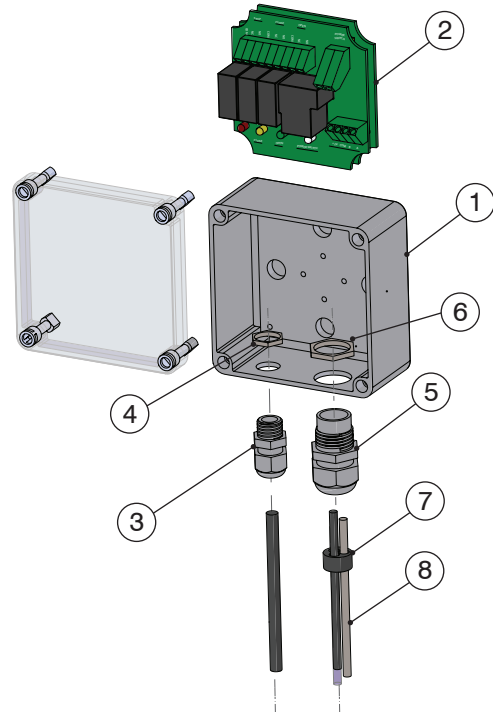

**13.11 OPTIONAL EXTERIOR TRAFFIC LIGHT / MIRROR IMAGE SIGN**

The LED traffic lights and mirror image drive warning sign improve loading dock safety.

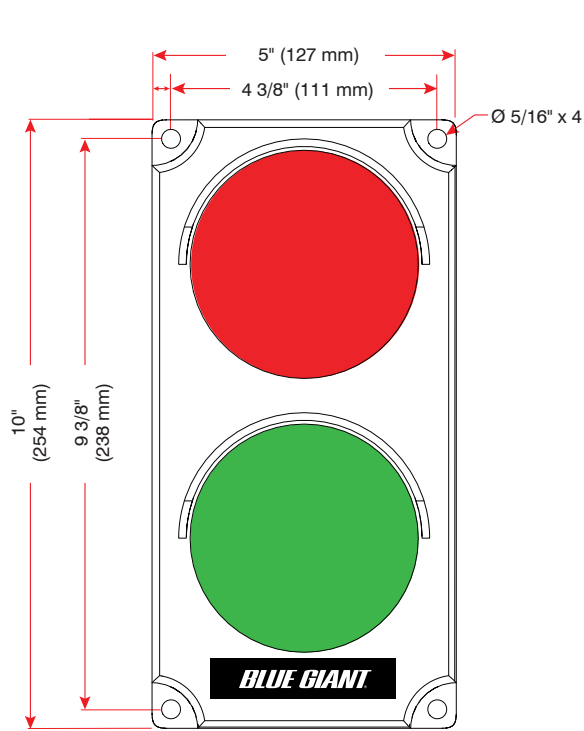

Exterior driver traffic light, part # 032-806.

**NOTE:** Mount to a flat surface. DO NOT deform light housing with irregular wall surface.

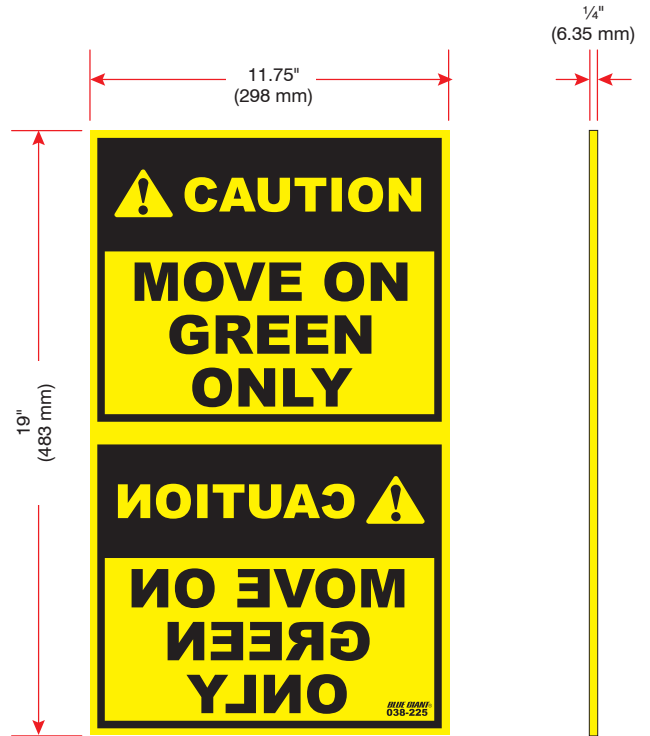

Exterior driver warning sign, part # 038-225.  
(French 038-225F / Spanish 038-225S / Portuguese 038-225P)

**14.0 DOCK LEVELER TROUBLESHOOTING**



**WARNING**

Do not attempt to install, make repairs or adjustments. Only a trained and authorized service technician should perform the installation process. Contact your local dealer or distributor for assistance.

PROBLEM	PROBLEM CAUSE
<p>Deck will not raise or lower when the 'DECK/DOWN' touch button is operated. Motor starts and runs.</p>	<ol style="list-style-type: none"> <li>1. Incorrect motor rotation                             <ul style="list-style-type: none"> <li>- Three phase or single phase:</li> <li>- See motor for motor rotation</li> </ul> </li> <li>2. Low or no hydraulic fluid in reservoir                             <ul style="list-style-type: none"> <li>- Check hydraulic fluid level</li> </ul> </li> <li>3. Pump faulty in powerpack                             <ul style="list-style-type: none"> <li>- Replace pump</li> </ul> </li> <li>4. Coupling between pump and motor broken / worn out                             <ul style="list-style-type: none"> <li>- Replace coupling</li> </ul> </li> <li>5. Pressure Relief Valve out of adjustment                             <ul style="list-style-type: none"> <li>- Turn pressure relief adjustment screw clockwise until deck begins to lift</li> </ul> </li> <li>6. Motor connected to incorrect Blue Genius™ motor terminals                             <ul style="list-style-type: none"> <li>- Refer to wiring diagram inside Blue Genius™ control panel</li> </ul> </li> </ol>
<p>Deck will not raise when the 'DECK' touch button is operated. Motor does not attempt to run. No sound is heard, main power supply is present.</p>	<ol style="list-style-type: none"> <li>1. Overhead door sensor (optional)                             <ul style="list-style-type: none"> <li>- Ensure that overhead door is completely open</li> <li>- Check overhead door sensor for any interference and if faulty, repair or replace</li> <li>- Check connector on terminal strip (Input 1)</li> </ul> </li> <li>2. Faulty coil on board contactor                             <ul style="list-style-type: none"> <li>- Replace power board</li> </ul> </li> <li>3. Wrong dock selected                             <ul style="list-style-type: none"> <li>- Contact factory or Blue Giant dealer</li> </ul> </li> </ol>
<p>Deck will not raise or lower when the 'DECK/DOWN' touch button is operated. Motor attempts to run, but the power supply circuit breaker / fuses trips / blows and the motor stops.</p>	<ol style="list-style-type: none"> <li>1. Faulty powerpack motor</li> <li>2. Faulty wiring</li> <li>3. Fuse / circuit breaker sized too low</li> <li>4. Incorrect supply voltage to motor (dual voltage motor)                             <ul style="list-style-type: none"> <li>- Check to ensure that applied voltage is the same as the motor-connected voltage</li> </ul> </li> </ol>
<p>Deck does not begin to move immediately when motor runs. Deck deployment has delayed action.</p>	<ol style="list-style-type: none"> <li>1. Air is trapped in the deck lifting cylinder                             <ul style="list-style-type: none"> <li>- Bleed the system. See item 3 below</li> </ul> </li> <li>2. Pressure relief valve set too low on powerpack</li> <li>3. Hydraulic hose was not pre-filled with fluid prior to installation                             <ul style="list-style-type: none"> <li>- To bleed air from the hydraulic system:</li> <li>- Operate the dock leveler and place the deck in its fully lowered, below level position</li> <li>- Wait 10 seconds and raise deck to home position. Retest. If delay is still present, repeat this step</li> </ul> </li> </ol>

14.0 DOCK LEVELER TROUBLESHOOTING CONT'D.

⚠	WARNING
---	---------

Do not attempt to install, make repairs or adjustments. Only a trained and authorized service technician should perform the installation process. Contact your local dealer or distributor for assistance.

PROBLEM	PROBLEM CAUSE
Deck rises partially and then stops. Motor continues to run and makes more noise than usual.	1. Low hydraulic oil in reservoir <ul style="list-style-type: none"> <li>- Possible fluid leak. Repair as required</li> <li>- Fill hydraulic reservoir with clean, new hydraulic fluid</li> <li>- Correct oil level is 3/4 full when the deck and lip are in their fully lowered, below level position</li> </ul>
Deck stops while lowering for no apparent reason.	1. Lowering speed is set too fast <ul style="list-style-type: none"> <li>- Adjustment is required to slow down the lowering. Refer to powerpack valve adjustment</li> <li>- Fall-safe velocity fuse will lock closed if lowering speed is too fast, and the deck will not lower any further</li> </ul> NOTE: To open a locked velocity fuse: "Press the 'DECK' cylinder - Raise the deck to its fully vertical position. Press the 'DOWN' button and retest, lowering for a full cycle. 2. Solenoid error <ul style="list-style-type: none"> <li>- Investigate and correct</li> </ul>
Deck does not move when the 'DOWN' button is operated. The deck is in the stored position and the motor does not run. A clicking sound may be heard inside Blue Genius™ control panel.	1. Motor not connected or miswired <ul style="list-style-type: none"> <li>- Check wiring diagram provided inside Blue Genius™ control panel</li> </ul>
Lip does not move right away.	1. Lip cylinder has air trapped inside <ul style="list-style-type: none"> <li>- Operate the lip (moving it up and down) while the deck is stored and also while the deck is completely deployed</li> </ul> 2. Hose length too long. Bleed system by cracking the hydraulic hose fitting at the lip cylinder port
Lip will not extend when the deck is in the stored position.	1. Check the hydraulic fluid level, and add fluid if needed. Do not overfill. Correct oil level is 3/4 full when the deck and lip are in their fully lowered, below level position 2. Deck button was not held long enough, creating a delay between the deck rising and the lip extending
Lip will not extend when the lip button is operated. The deck does rise when 'DECK' button touched	1. SV3 solenoid valve is inactive. Check the wiring for SV3. Verify that the SV3 solenoid stem is not damaged and that the SV2 coil is not open 2. SV1 solenoid is active. Check wiring or damaged stem
Lip operates when the 'DOWN' button is operated.	1. SV3 solenoid is active <ul style="list-style-type: none"> <li>- Check the I/O board connections for proper termination of solenoid valves</li> <li>- Check wiring to solenoid valve connectors</li> </ul> 2. SV2 is inactive and SV3 is active
Lip will not fold when the 'LIP' button is operated.	1. SV1 or SV3 (or both) solenoid valves are inactive <ul style="list-style-type: none"> <li>- Check wiring to the solenoid valves</li> </ul>

**15.0 BLUE GENIUS™ LCD MESSAGES**

 <b>WARNING</b>
<p>Do not attempt to install, make repairs or adjustments. Only a trained and authorized service technician should perform the installation process. Contact your local dealer or distributor for assistance.</p>

MESSAGE	EXPLANATION
'Restraint is Engaged or Bypassed.' 'Dock Leveler Restored.'	Restraint has been engaged or bypassed; dock leveler may now be deployed. (Applies to combo units with vertical storing dock levelers only)
'Raising Leveler'	The 'Deck' button is being touched: the deck is now rising from the deployed position.
'Lowering Leveler'	The 'Down' button is being touched: the deck is now lowering.
'Deck Moving'	The deck is in motion: either deploying or lowering to the parked position. This message appears when the 'Deck' button has been released.
'Raising Lip'	The 'Lip' button is being touched or the operator has held the 'Deck' button until the lip has been deployed. This message also appears when the 'Deck' button is held until the vertical storing dock leveler has reached the home position.
'Lowering Lip'	The 'Lip' button has been touched, causing the lip to lower for below level loading.
'Leveler is Restored'	The dock leveler is in the home position.

**16.0 WIRING DIAGRAMS**

<b>NOTICE</b>
<p>The following wiring diagrams are sample configurations only. Wiring diagrams specific to your needs will be provided inside the control panel and/or as part of your submittal package.</p>

16.1 WIRING DIAGRAM—115V SINGLE PHASE

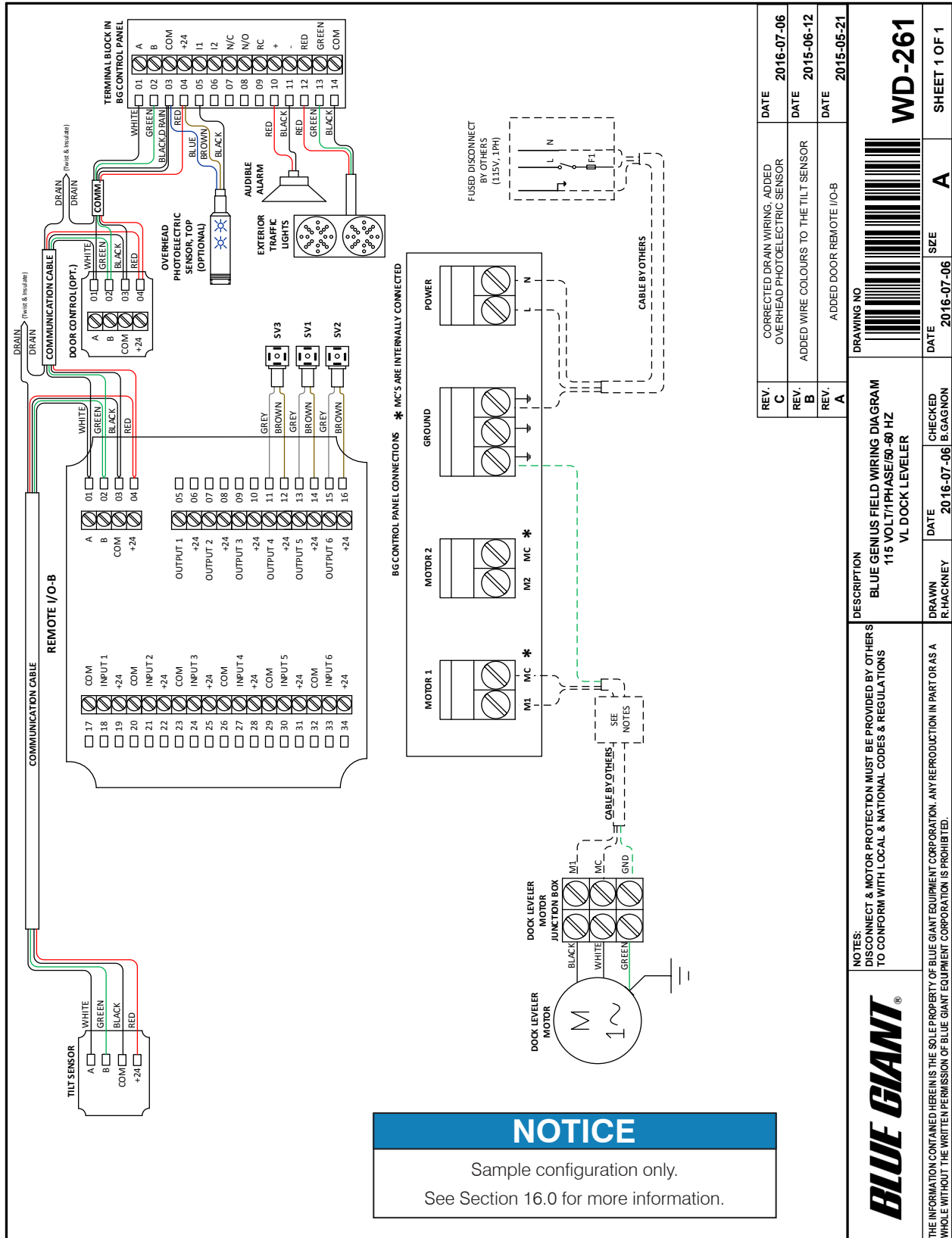

REV. C	CORRECTED DRAIN WIRING, ADDED OVERHEAD PHOTOELECTRIC SENSOR	DATE	2016-07-06
REV. B	ADDED WIRE COLOURS TO THE TILT SENSOR	DATE	2015-06-12
REV. A	ADDED DOOR REMOTE I/O-B	DATE	2015-05-21

DRAWING NO		WD-261	
DESCRIPTION		BLUE GENIUS FIELD WIRING DIAGRAM 115 VOLT/1PHASE/50-60 HZ VL DOCK LEVELER	
DRAWN	DATE	CHECKED	DATE
R-HACKNEY	2016-07-06	B.GAGNON	2016-07-06
SIZE		A	
SHEET 1 OF 1			



NOTES:  
DISCONNECT & MOTOR PROTECTION MUST BE PROVIDED BY OTHERS TO CONFORM WITH LOCAL & NATIONAL CODES & REGULATIONS  
THE INFORMATION CONTAINED HEREIN IS THE SOLE PROPERTY OF BLUE GIANT EQUIPMENT CORPORATION. ANY REPRODUCTION IN PART OR AS A WHOLE WITHOUT THE WRITTEN PERMISSION OF BLUE GIANT EQUIPMENT CORPORATION IS PROHIBITED.

**NOTICE**  
Sample configuration only.  
See Section 16.0 for more information.

16.2 WIRING DIAGRAM—208-600V THREE PHASE

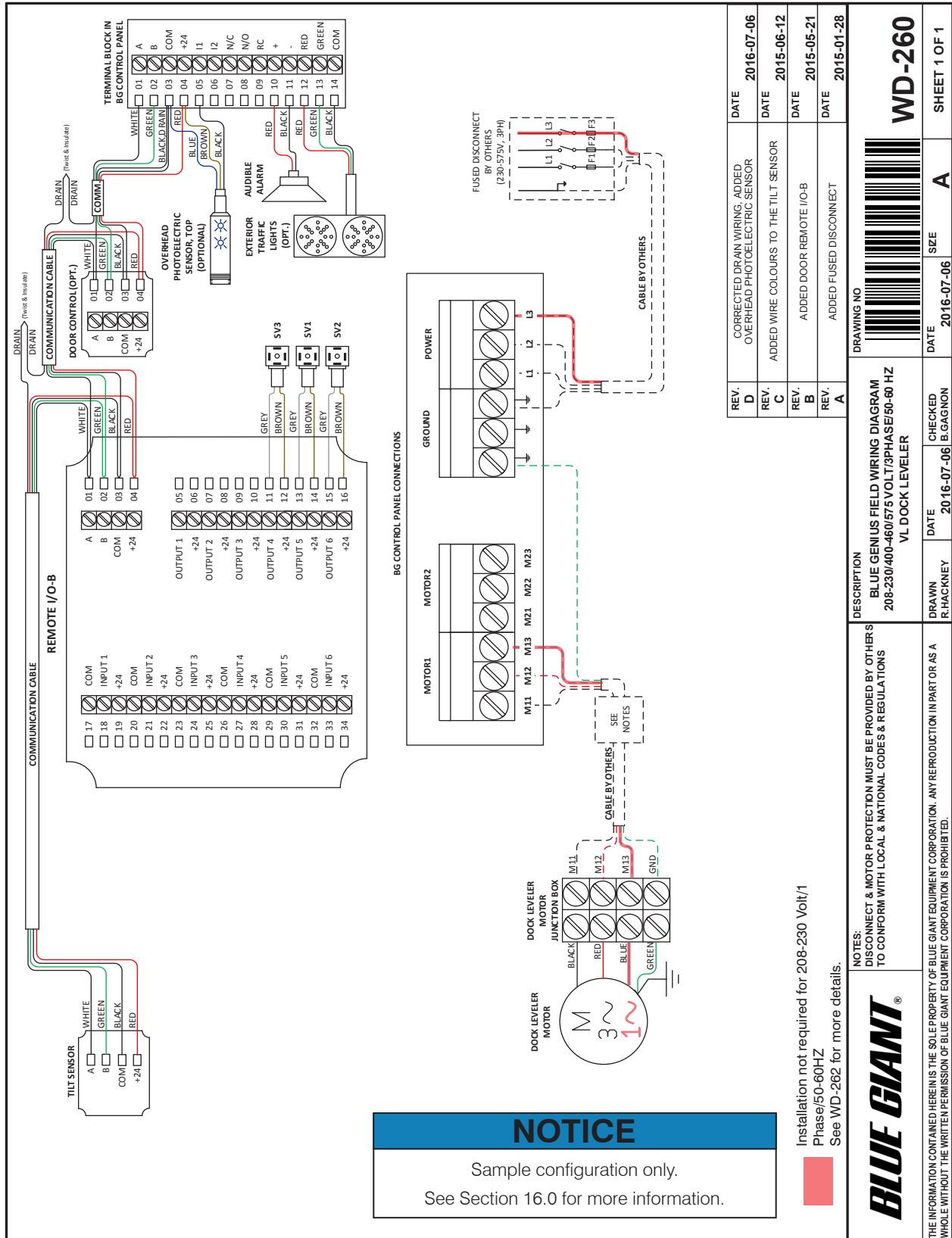

**NOTICE**

Sample configuration only.  
See Section 16.0 for more information.

Installation not required for 208-230 Volt/1 Phase/50-60HZ  
See WD-262 for more details.



**BLUE GIANT®**

**NOTES:**  
DISCONNECT & MOTOR PROTECTION MUST BE PROVIDED BY OTHERS TO CONFORM WITH LOCAL & NATIONAL CODES & REGULATIONS  
THE INFORMATION CONTAINED HEREIN IS THE SOLE PROPERTY OF BLUE GIANT EQUIPMENT CORPORATION. ANY REPRODUCTION IN PART OR AS A WHOLE WITHOUT THE WRITTEN PERMISSION OF BLUE GIANT EQUIPMENT CORPORATION IS PROHIBITED.

**DESCRIPTION**  
BLUE GENIUS FIELD WIRING DIAGRAM  
208-230/400-460/575 VOLT/3PHASE/50-60 HZ  
VL DOCK LEVELER

**DRAWN** R-HACKNEY  
**CHECKED** B.GAGNON  
**DATE** 2016-07-06  
**SIZE** A



**DATE** 2016-07-06  
**DATE** 2015-06-12  
**DATE** 2015-05-21  
**DATE** 2015-01-28

SHEET 1 OF 1



**BLUE GIANT**<sup>®</sup>  
BLUE GIANT EQUIPMENT CORPORATION

**Corporate** 410 Admiral Blvd  
Mississauga, ON, Canada L5T 2N6  
t 905.457.3900 f 905.457.2313

**USA** 6350 Burnt Poplar Road  
Greensboro, NC 27409  
[www.bluegiant.com](http://www.bluegiant.com)