

FROM BLUEPRINT TO BAY:
**DOCK SYSTEM
DESIGN GUIDE**

BB

BLUE GIANT®

TABLE OF CONTENTS

- 01** Designing for Efficiency and Safety at the Loading Dock
- 03** Key Considerations When Designing the Dock Area
- 04** Docking Made Easy: Understanding Facility Types
- 08** From Cold Storage to Cross-Dock: Choosing the Right Equipment
- 11** Trailer Configurations: Understanding What You're Working With
- 12** Truck & Trailer Types at the Loading Dock
- 15** Apron Space: Planning for Safe Trailer Movement
- 16** Dock Positioning: Choosing the Right Layout for Your Facility
- 18** Dock Height: Aligning for Safe and Efficient Loading
- 20** Dock Approach: Planning for Safe Vehicle Access and Dock Protection
- 22** Managing Declined Dock Approaches: Ensuring Safety with Proper Pit Projection
- 23** Dock Door Size and Height: Planning for Efficient and Flexible Operations
- 25** Dock Bumpers: Essential Protection for Your Facility
- 26** What is a Dock Leveler?
- 27** Dock Leveler Selection: Choosing the Right Size and Capacity for Safety and Efficiency

TABLE OF CONTENTS

- 30** Understanding Dock Levelers: Types, Operation, and Safety
- 38** Optional Features for Enhanced Dock Leveler Performance
- 40** Dock Leveler Installation Styles: Choosing the Right Fit for Your Project
- 42** Securing the Dock: Vehicle Restraint Systems and Their Role in Safety
- 48** Essential Dock Safety Equipment: Modern Tools for Safer Operations
- 49** Smart Dock Controls: Simplifying Safety and Efficiency
- 50** Seals & Shelters: Enhancing Efficiency, Safety, and Protection at the Dock
- 55** Elevating Docks: Flexible Ground-to-Trailer Solutions
- 56** Completing the Dock: Accessory Planning & Integration for Safety & Productivity
- 61** Where Standards Meet Strength: The Blue Giant Advantage
- 63** Master Site Survey

DESIGNING FOR EFFICIENCY AND SAFETY AT THE LOADING DOCK

This guide was developed to help you design an effective loading dock area and choose the right equipment for your facility. If you need support during the planning process, your authorized Blue Giant representative is ready to help.

This guide covers the key areas of dock design and equipment selection:

1. Dock Area Layout
2. Dock Levelers
3. Dock Bumpers
4. Vehicle Restraints
5. Additional Safety Equipment
6. Dock Seals and Shelters
7. Elevating Docks

We recommend using this guide as a tool to support safe, efficient, and future-ready dock designs.

For more information about Blue Giant products—or to find a local authorized dealer—please visit: www.BlueGiant.com



In today's fast-moving and competitive environment, the smooth flow of products in and out of a facility is more important than ever. To achieve this, careful attention must be given to the design of the loading dock area.

Coordinating dock heights, door sizes, and choosing the right equipment are all key to ensuring efficient operations. But efficiency alone isn't enough—safety is just as critical.

Modern workplaces have zero tolerance for unsafe practices. Installing proper safety equipment at the dock is a vital first step in reducing the risk of accidents and costly downtime. However, even the best equipment is only effective if it's used correctly. That's why it's essential that all dock personnel are trained to operate equipment safely and to recognize warning signs.

If workers don't fully understand how a system works, they're less likely to use it properly. It's the employer's responsibility to ensure all staff receive proper training. Blue Giant Authorized Representatives can help by providing expert recommendations and after-sales training to ensure the right equipment is selected—and used safely.

When planning a loading dock, it's also important to think ahead. Future needs—such as additional door openings or expanded storage—should be factored into the building design from the start. Planning for future changes in equipment size and capacity now can help avoid costly redesigns later.

KEY CONSIDERATIONS WHEN DESIGNING THE DOCK AREA

Designing a functional and safe dock area requires careful planning and attention to several key factors:

- Facility Types
- Application Types
- Trailer Configurations
- Apron Space
- Dock Positioning
- Dock Height
- Dock Approach
- Door Size
- Loading Dock Equipment
 - Dock Bumpers
 - Dock Leveler types, selection and Installation
 - Vehicle Restraints
 - Additional Safety Equipment
 - Seals & Shelters
 - Dock Lifts
- Quality & Compliance Standards



DOCKING MADE EASY: UNDERSTANDING FACILITY TYPES

Optimizing Material Handling and Dock Equipment for Every Facility Type

Material handling and dock systems are critical components of any facility, and their design and equipment requirements vary widely depending on the type of operation. Industrial manufacturing sites, distribution centers, retail facilities, and specialized operations like cold storage or hazardous materials handling each have unique needs for efficiency, safety, and operational flow.

A fully equipped facility integrates dock levelers, vehicle restraints, seals and shelters, dock lifts, conveyors, pallet handling systems, and other material handling equipment to ensure smooth, safe, and efficient movement of goods from arrival to storage or production.

Understanding the different facility types and how their operations influence equipment selection helps maximize productivity, protect personnel and products, and ensure the right tools are in place for every material handling scenario.

Transportation & Logistics

Cross-Dock Facilities – Fast-paced operations; edge-of-dock levelers, pit-style levelers, electric or hydraulic vehicle restraints, inflatable or retractable seals, and low-profile dock lifts.

Intermodal Terminals (Rail-to-Truck, Container Yards) – Heavy and irregular loads; heavy-duty hydraulic levelers, hydraulic restraints, full-access or stationary seals and shelters, and high-capacity dock lifts.

Freight Forwarding Centers – Mixed freight types; hydraulic or mechanical levelers, hydraulic or electric restraints, inflatable or retractable seals, and stationary or low-profile dock lifts.

Parcel & Courier Sorting Hubs – Frequent small shipments; edge-of-dock levelers, pit-style levelers, Wheel or intellichock restraints, retractable seals, and low-profile dock lifts.

Industrial & Manufacturing

General Manufacturing – Moderate to heavy loads; use mechanical or hydraulic levelers, mechanical or hydraulic vehicle restraints, retractable or stationary seals and shelters, and stationary or low-profile dock lifts.

Heavy Industry / Steel & Metal Fabrication – Very heavy loads; heavy-duty hydraulic levelers, hydraulic vehicle restraints, full-access or stationary shelters, and low-profile or high-capacity dock lifts.

Automotive Assembly & Parts Plants – Frequent shipments; edge-of-dock levelers, pit-style levelers, electric or hydraulic vehicle restraints, inflatable or retractable seals, and low-profile dock lifts.

Pharmaceutical & Biotech Manufacturing – Temperature- or contamination-sensitive; vertical style levelers, electric, mechanical, hydraulic restraints, inflatable or stationary seals, and stationary dock lifts.

Warehousing & Distribution

General Warehouses – Moderate to high-volume shipments; mechanical or hydraulic levelers, mechanical or hydraulic vehicle restraints, retractable or stationary seals and shelters, and stationary or low-profile dock lifts.

Distribution Centers (Retail, E-commerce, B2B) – High-throughput operations; edge-of-dock levelers, pit-style levelers, electric or hydraulic vehicle restraints, inflatable or retractable seals, and low-profile dock lifts.

Cold Storage & Refrigerated Warehouses – Temperature-sensitive goods; Vertical style levelers, hydraulic or electric restraints, insulated or stationary seals and shelters, and low-profile or refrigerated-compatible dock lifts.

Perishable Goods Warehouses (Produce, Dairy, Meat) – Hygiene-critical handling; Vertical style levelers, pit-style dock levelers, hydraulic/ mechanical, or electric restraints, inflatable seals and shelters, and low-profile or stationary dock lifts.

Dry Goods Storage – High-frequency shipments; mechanical or hydraulic levelers, mechanical or hydraulic restraints, retractable or stationary seals, and stationary or low-profile dock lifts.

Specialized Facilities

Military & Government Supply Depots – Heavy and irregular loads; heavy-duty hydraulic levelers, hydraulic or electric restraints, full-access or stationary seals and shelters, and high-capacity dock lifts.

Airports (Cargo Terminals, Baggage Handling) – High-frequency shipments; mechanical or hydraulic levelers, edge of dock levelers, electric or hydraulic restraints, inflatable or retractable seals, and low-profile or stationary dock lifts.

Seaports & Container Terminals – Very heavy and large containers; heavy-duty hydraulic levelers, hydraulic restraints, full-access or stationary seals, and high-capacity dock lifts.

Mining & Resource Distribution Sites – Bulk and rugged loads; heavy-duty hydraulic levelers, hydraulic restraints, full-access or stationary shelters, and high-capacity dock lifts.

Hospitals & Medical Supply Distribution – Sensitive and temperature-controlled materials; hydraulic or mechanical levelers, Vertical style levelers, electric or hydraulic restraints, inflatable or stationary seals, and low-profile or stationary dock lifts.

Universities / Campus Facilities (Receiving Docks) – Mixed small and medium shipments; mechanical or hydraulic levelers, mechanical or hydraulic restraints, retractable or stationary seals, and stationary or low-profile dock lifts.

Chemical & Hazardous Material Facilities – Safety-critical loads; pit-style dock levelers, hydraulic restraints, compression or stationary seals, and low-profile dock lifts.

Retail & Commercial

Big-Box Retail Stores – High-frequency deliveries; mechanical or hydraulic levelers, edge of dock levelers, mechanical or hydraulic restraints, retractable or stationary seals and shelters, and low-profile or stationary dock lifts.

Grocery Stores & Supermarkets – Perishable goods and frequent shipments; mechanical or hydraulic levelers, edge of dock levelers, hydraulic or electric restraints, inflatable or retractable seals, and low-profile or stationary dock lifts.

Shopping Mall Receiving Docks – Varied delivery sizes and shared dock bays; hydraulic or mechanical levelers, electric or hydraulic restraints, retractable or stationary seals, and stationary dock lifts.

Furniture & Appliance Distribution – Large, bulky shipments; heavy-duty hydraulic levelers, hydraulic restraints, full-access or stationary seals and shelters, and high-capacity dock lifts.

Food & Beverage

Food Processing Plants – Frequent handling of bulk ingredients; hydraulic or mechanical levelers, hydraulic or electric restraints, inflatable or retractable seals, and low-profile or stationary dock lifts.

Beverage Bottling & Distribution – Heavy pallets and bottles; heavy-duty hydraulic levelers, hydraulic restraints, full-access or stationary seals, and high-capacity dock lifts.

Breweries & Wineries – Mixed load types; mechanical or hydraulic levelers, edge of dock levelers, hydraulic or electric restraints, retractable or stationary seals, and low-profile dock lifts.

Meat Packing & Poultry Plants – Temperature- and hygiene-sensitive; Vertical style dock levelers, hydraulic or electric restraints, inflatable or sanitary seals, and low-profile or stationary dock lifts.

Agricultural Co-ops & Grain Terminals – Bulk and irregular loads; heavy-duty hydraulic levelers, hydraulic restraints, full-access or stationary seals, and high-capacity dock lifts.

FROM COLD STORAGE TO CROSS-DOCK: CHOOSING THE RIGHT EQUIPMENT

How Application Type Shapes Loading Dock Requirements

When designing industrial facilities, loading dock and material handling needs differ for each operation. High-volume distribution centers require fast, efficient loading and unloading, while temperature-controlled facilities must protect sensitive goods. Heavy industrial sites handle large or heavy loads, demanding durable, reinforced equipment. Retail and commercial locations prioritize space efficiency and security. Every facility type shapes the choice of dock equipment to ensure smooth, safe, and productive operations.

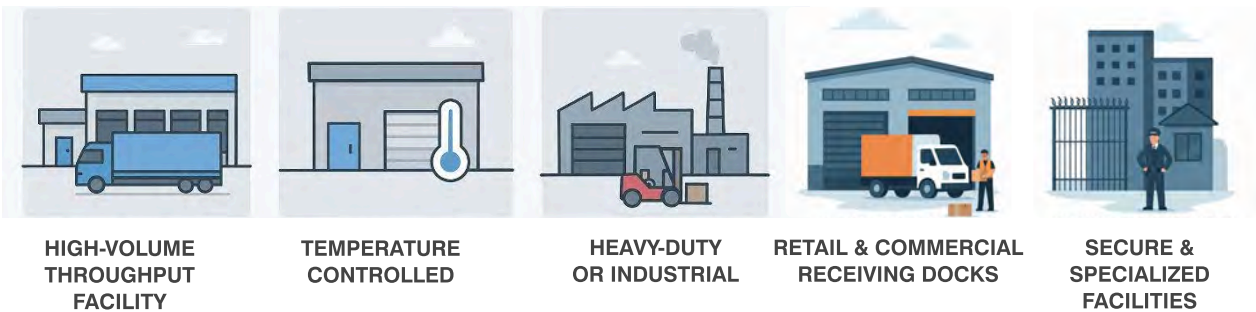

High-Volume Throughput Facilities

Facilities where speed and efficiency are critical, often requiring multiple dock positions, advanced traffic flow management, and interlocked restraint systems.

- Cross-Dock Terminals (LTL freight, parcel hubs, courier facilities)
- E-Commerce Fulfillment Centers
- Retail Distribution Centers (big-box, supermarkets, chain stores)
- Intermodal Rail & Container Yards
- Air Cargo Terminals

Design Considerations:

- Multiple dock positions in sequence
- Vehicle restraints for high turnover
- Dock management systems (lighting, signaling, automation)

Temperature-Controlled Facilities

Specialized for perishable, refrigerated, or frozen goods. Require airtight seals and fast equipment operation to preserve climate conditions.

- Cold Storage Warehouses
- Frozen Food Distribution
- Meat Packing & Poultry Plants
- Pharmaceutical Distribution & Biotech Facilities Rail & Container Yards
- Temperature Sensitive/controlled Beverage Manufacturing or Distribution

Design Considerations:

- Vertical Storing Levelers for environmental separation
 - Inflatable dock seals/shelters
 - Door interlocks with refrigeration systems
-

Heavy-Duty / Industrial Facilities

Support oversized, heavy, or hazardous goods. Require durable equipment and specialized safety measures.

- General Manufacturing Facilities
- Automotive Assembly & Parts Plants
- Steel, Metal, and Machinery Fabrication
- Mining Supply & Resource Processing Sites

Design Considerations:

- Extra capacity dock levelers (high tonnage)
- Reinforced vehicle restraints
- Spill containment & safety interlocks

Retail & Commercial Receiving Docks

Facilities with mixed-frequency deliveries, often in urban or restricted environments.

- Big-Box Retail Stores
- Supermarkets & Grocery Stores
- Shopping Mall Receiving Areas
- Furniture & Appliance Distribution
- Campus, University, or Hospital Receiving Docks

Design Considerations:

- Smaller dock bays, limited space
 - Vehicle restraints for high turnover
 - Security and theft prevention systems
-

Secure & Specialized Facilities

Where safety, controlled access, or regulatory compliance drives dock bay design..

- Airports (Cargo & Baggage Handling)
- Seaports & Container Terminals
- Medical Supply Warehouses & Hospitals
- Hazardous Material Sites
- Chemical Plants & Hazardous Material Warehouses

Design Considerations:

- Integrated access control with dock equipment
- Vehicle restraints with fail-safes
- Fire-rated or blast-resistant dock doors

TRAILER CONFIGURATIONS: UNDERSTANDING WHAT YOU'RE WORKING WITH

Understanding Truck & Trailer Types at the Loading Dock

A well-designed loading dock must accommodate a wide range of vehicles, from small delivery vans and box trucks to large semi-trailers and specialized trailers. It's essential to understand which types of trucks and trailers your facility will most often service, as this knowledge directly impacts dock design decisions such as height, equipment selection, and overall layout.

Knowing these differences is critical because dock height and leveler types must match the typical trailer heights to ensure safe and efficient loading operations. Additionally, specialized trailers like reefers require proper dock seals to preserve the cold chain, while others may need specific restraints, ramps, or wheel chocks. When your facility handles multiple trailer types, flexible dock layouts and equipment become vital to accommodate varying dimensions and reduce downtime.

If your facility operates with a captive fleet—meaning a consistent trailer type—designing the dock is more straightforward and can be precisely tailored. However, if multiple carriers or diverse trailers visit your site, prioritize the most common types but also plan for occasional variations to ensure smooth operations.

By carefully considering your fleet profile and the trailers you expect, you can design a loading dock that maximizes operational efficiency, improves worker safety, and adapts to your business's evolving needs.

TRUCK & TRAILER TYPES AT THE LOADING DOCK

Standard Semi-Trailers (53' Dry Vans)

The most common trailers encountered in freight operations are standard semi-trailers, typically 53 feet long with an enclosed, climate-uncontrolled cargo space designed for dry goods. These trailers are widely used across industries such as warehousing, manufacturing, and retail supply chains. Standard semi-trailers usually require dock heights between 48" and 52".



Delivery Vans & Light Trucks

These are small vehicles typically used for local or last-mile deliveries. They are ideal for transporting smaller loads in tight urban environments and allow for quick unloading. You will often find these trucks servicing retail stores, food service providers, and parcel delivery companies. Delivery vans typically require smaller loading areas or lift gates.



Box Trucks

Box trucks are medium-sized enclosed vehicles, usually ranging from 12 to 26 feet in length. They are commonly used for regional deliveries involving moderate cargo volumes. These trucks are frequently seen in logistics operations, moving services, and smaller distribution centers. When designing docks for box trucks, consider their lower bed heights and varied ICC bar positions. Consider versatile dock levelers or edge of docks, flexible seals or shelters, and wheel-based restraints.



Refrigerated Trailers (Reefers)

Reefers are insulated, temperature-controlled trailers used to transport perishable goods. Because they maintain a cold chain, they require specialized dock seals and electrical hookups at the loading dock. These trailers are essential in food distribution, pharmaceuticals, and chemical industries. Reefers need specialized dock seals and power connections to maintain temperature control.



Flatbed Trailers

Flatbed trailers are open trailers without sides or a roof, designed for carrying oversized or irregularly shaped loads. They are often used to transport heavy machinery, building materials, and equipment that cannot fit into enclosed trailers. Loading and unloading these trailers requires special procedures and safety measures.



Tanker & Bulk Trailers

These trailers are specifically designed to carry liquids, gases, or bulk materials. They are commonly used in chemical, fuel, and food-grade industries. Due to the nature of their cargo, tanker and bulk trailers need specialized docking setups and strict safety protocols during loading and unloading.



Truck Bed and Overall Height Ranges

The Truck Bed Height Total Range indicates the height from the ground to the trailer bed. This information helps determine what height the dock should be situated within the facility to have a level bridge to the trailer. That is why the industry average dock height is 48" as a Standard Semi Trailer Truck has a trailer height of 44" - 52" making it ideal for bridging.

The overall truck height range is also important to ensure the overhead door, dock seals, and shelters are properly sized and positioned for smooth access, effective sealing, and safe clearance.

	TRUCK BED HEIGHT TOTAL RANGE		OVERALL TRUCK HEIGHT TOTAL RANGE	
	MIN	MAX	MIN	MAX
CONTAINER	56"	62"	12'-2"	13'-6"
REEFER	50"	62"	12'-6"	13'-6"
STANDARD SEMI-TRAILER	44"	52"	12'-0"	13'-6"
CITY DELIVERY	44"	48"	11'-0"	13'-6"
HIGH CUBE VAN	36"	42"	13'-0"	13'-6"
FURNITURE VAN	24"	36"	13'-0"	13'-6"
STEP VAN	20"	30"	8'-6"	10'-0"
PANEL TRUCK	20"	24"	8'-6"	9'-0"
STRAIGHT TRUCK	36"	48"	10'-6"	12'-0"
FLATBEDS	48"	60"	-	-

APRON SPACE: PLANNING FOR SAFE TRAILER MOVEMENT

Apron Space

Apron space refers to the clear area in front of the loading dock used for maneuvering and positioning trailers. Proper planning ensures smooth vehicle access, reduces risk, and supports efficient traffic flow.

Two main factors must be considered:

Facilities with mixed-frequency deliveries, often in urban or restricted environments.

- Overall vehicle length
- Traffic pattern and movement

As a general rule, a truck with an overall length of 65 feet (21.7 meters) requires a minimum apron space of 135 - 150 feet (41 - 46 meters). Always base calculations on full vehicle length—not jockey truck dimensions—as yard trucks need significantly less room than standard trailers. **Use rule of thumb: truck length × 2.**

Surface materials also matter.

If using asphalt, install a concrete landing strip to prevent trailer landing gear from sinking during warm weather.

The landing strip should match the longest trailer expected, minus 7 feet.

Avoid gravel surfaces—they create uneven, unsafe conditions.

To ensure the most accurate and code-compliant layout, especially for complex or high-traffic sites, consult with an authorized Blue Giant representative during the planning phase.

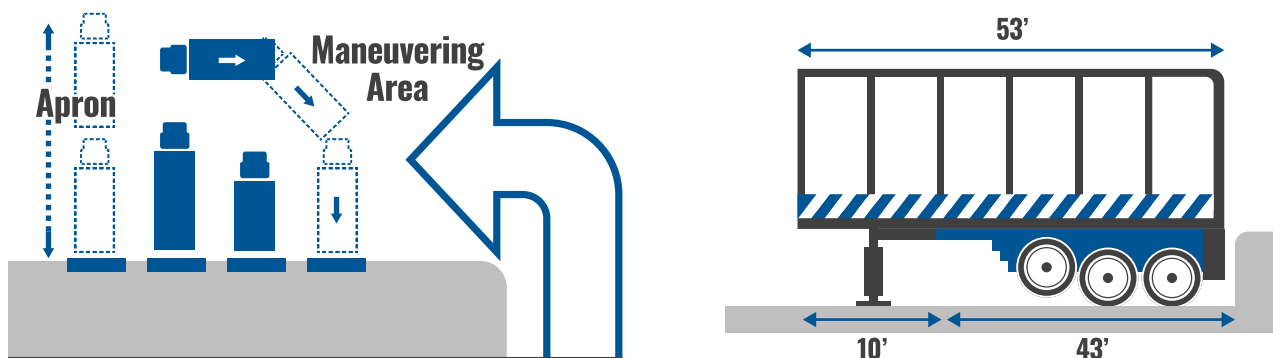

DOCK POSITIONING: CHOOSING THE RIGHT LAYOUT FOR YOUR FACILITY

Dock Position

Dock positioning refers to the physical layout of dock doors, levelers, and surrounding space. The most common and efficient configuration is a flush dock, where the face of the dock is aligned with the building's exterior wall. In this setup, doors are typically spaced on 12–14-foot centers, allowing enough room for trailers up to 10 feet wide, including mirrors. If special or oversized trailers are expected, door spacing may need to be increased.

When space is limited, narrower spacing can be used, but it is important to plan for dock seals or shelters to maintain proper weather protection and operational safety.

Dock Layout Options

Flush Docks

These are the most widely used design. To protect the building wall and any dock seals on a level approach, the foundation or dock bumper should extend 4 inches (101.6 mm) beyond the wall.

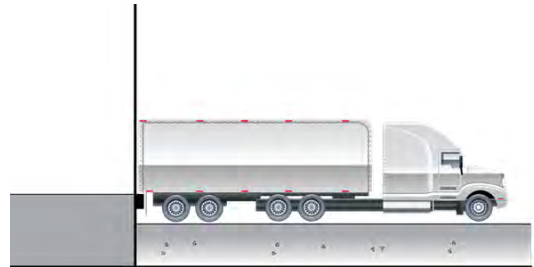

Enclosed Docks

Used where climate control, security, product protection, or overhead lifting is required. While effective, enclosed docks are less common due to higher construction costs and concerns about vehicle exhaust buildup.



Open Docks

Generally not recommended. Open docks offer minimal protection from weather and are more vulnerable to wind-blown debris and security issues. If used, a protective canopy is essential.



Note: In all outdoor dock types, a canopy should be installed. When planning for a canopy on a sloped dock approach, be sure to adjust the canopy height to account for the increased trailer height caused by the grade.

Sawtooth Docks

A good solution when there is limited apron space for trailer maneuvering. These docks are angled along the building, allowing trailers to back in at an angle. However, they take up more interior floor space and leave the dock exposed, so a canopy is strongly recommended to protect workers and products from the elements.

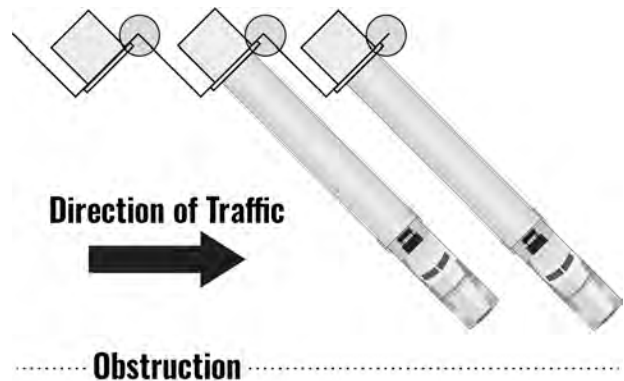

DOCK HEIGHT: ALIGNING FOR SAFE AND EFFICIENT LOADING

Dock Heights

Dock height plays a critical role in determining the grade (slope) between the dock and the trailer bed. The slope must stay within safe operating limits to avoid equipment issues and safety risks.

Maximum grade guidelines:

Facilities with mixed-frequency deliveries, often in urban or restricted environments.

- Overall vehicle length
- Traffic pattern and movement

Exceeding these limits can cause equipment to "hang up," damage to materials handling equipment, or load spillage—all of which reduce efficiency and increase risk.

Vehicle bed heights typically range from 30" to 62", but the key question is:

Which trailer height will your facility handle most frequently?

Once identified, the majority of dock heights should match that range to reduce steep grade transitions and improve loading efficiency.

The most common dock height is 48" to 52", as this range accommodates most standard freight trailers. However, if your operation involves significant variation in trailer heights, custom dock levelers can be installed to manage the difference safely.

A well-designed dock area should offer enough flexibility to handle a variety of trailer sizes while maintaining safe and smooth equipment operation.

TRUCK/TRAILER TYPE	LOAD BED HEIGHT TOTAL RANGE	
	MIN	MAX
CONTAINER	56"	62"
REFRIGERATED	50"	62"
DOUBLE AXLE SEMI-TRAILER	44"	52"
CITY DELIVERY	44"	48"
HIGH CUBE VAN	36"	42"
FURNITURE VAN	24"	36"
STEP VAN	20"	30"
PANEL TRUCK	20"	24"
STRAIGHT TRUCK	36"	48"
FLATBEDS	48"	60"

Industry Average Dock Height – 48"

DOCK APPROACH: PLANNING FOR SAFE VEHICLE ACCESS AND DOCK PROTECTION

Dock Approach

The dock approach refers to the slope and surface configuration leading up to the loading dock. It plays a critical role in how trailers are positioned and how the dock performs over time. There are three general types of approaches:

- **Level** – Flat surface leading directly to the dock
- **Inclined** – Slopes away from the building
- **Declined** – Slopes toward the building

The ideal approach is a slight incline away from the building. This allows for smooth trailer alignment, promotes water runoff, and helps prevent building damage caused by misaligned trailers—especially when jockey trucks are used.

Calculating the Grade

To determine the slope of the dock approach:

1. Measure the vertical height difference between the dock and a point 50 feet (600 inches) straight out from the dock.
2. Divide the height by the length, then multiply by 100.

Example: 18" rise / 600" run = 0.03 → 3% grade

Note: Grades above 10% are not recommended, as they compromise dock leveler performance and safety.

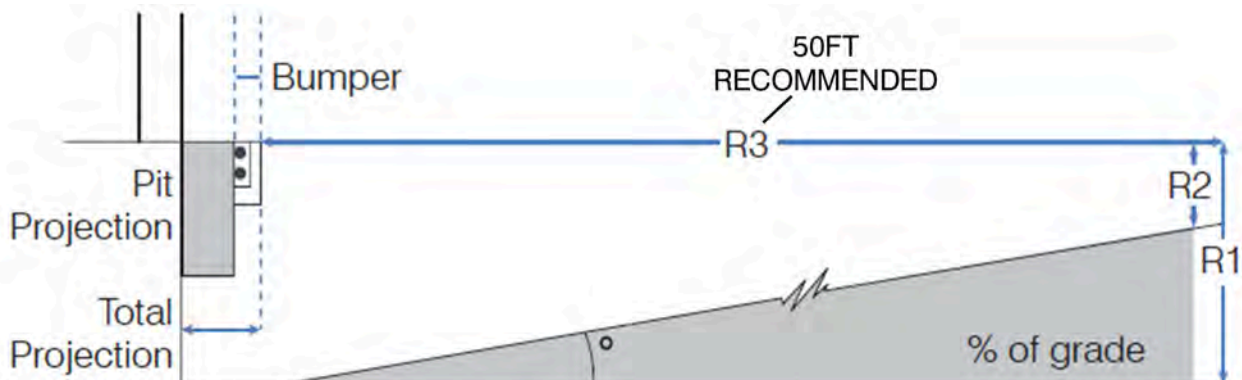

Declined Approach: Considerations and Cautions

When the dock must be constructed at grade level, a declined approach may be necessary.

However, this design introduces several challenges:

- Snow removal difficulty
- Water pooling and poor drainage
- Debris buildup
- Increased impact forces from trailers backing in
- Risk of trailer tops damaging the building wall

To counter these risks:

- Increase dock bumper projection or project the dock face to absorb trailer impact (Pit Projection)
- If dock projection isn't feasible (e.g., during a retrofit), install build-out blocks supplied by the dock leveler manufacturer
- Seal and restraint systems must be adapted for the angle:
 - Dock seals should be tapered to match the trailer's angle to avoid gaps and product damage
 - Vehicle restraints must be extended far enough to engage the trailer properly

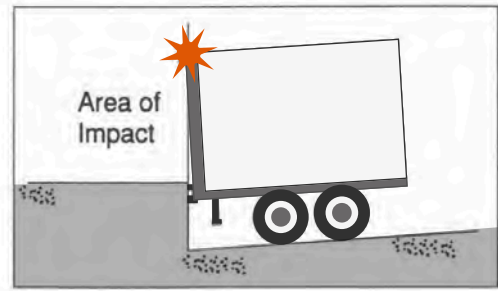

Declined Approach

MANAGING DECLINED DOCK APPROACHES: ENSURING SAFETY WITH PROPER PIT PROJECTION

Projection Guidelines for Declined Approaches

The more decline (grade %), the more projection is required.

- Minimum bumper projection: 4"
- For 1%–3% grades, additional projection may be needed using horizontal bumper extensions or thicker bumpers
- Ensure a minimum lip overlap of 4"–6" on the trailer bed for safe dock leveler operation

Including a pit projection is critical when designing a dock with a declined approach. As the trailer backs down the slope toward the building, the rear of the trailer naturally tilts upward, increasing the risk of the trailer's upper edge making contact with the building wall. Without proper projection, this impact can damage the structure, compromise dock seals, and shorten the lifespan of equipment. A pit projection extends the dock face outward, allowing the trailer to engage safely with the dock bumpers rather than the building. This added clearance helps absorb impact forces, protects critical components, and ensures safe, reliable operation—especially in facilities where space constraints or grade-level construction make declined approaches necessary.

GRADE %	PIT PROJECTION	MIN BUMPER	TOTAL PROJECTION
0%	LEVEL	4"	4"
1%	2"	4"	6"
2%	3"	4"	7"
3%	4"	4"	8"
4%	5"	4"	9"
5%	6"	4"	10"
6%	7"	4"	11"
7%	8"	4"	12"
8%	9"	4"	13"
9%	10"	4"	14"
9%	11"	4"	15"

For decline approaches, Pit Projections prevent the top of truck from damaging the building wall.

DOCK DOOR SIZE AND HEIGHT: PLANNING FOR EFFICIENT AND FLEXIBLE OPERATIONS

Door Size

Selecting the correct dock door size is essential for smooth, safe, and efficient loading dock operations. Improperly sized doors can lead to reduced productivity, product damage, and logistical challenges. Both current trailer types and future loading needs should be considered when planning.

While door sizes can be customized, it is important to plan based on the product types, loading equipment, and potential future changes. Investing in the right door size now can significantly improve throughput, reduce damage, and lower long-term operational costs.

Door Heights

Trailer heights can vary widely—from low flatbeds (around 48") to high cube trailers (up to 162" from ground level). The most common dock height is between 48" and 52", and typical door height options include:

8' (96") High Doors

- Suitable for many standard applications.
- Do not allow full floor-to-ceiling loading.
- Less efficient when trying to optimize trailer space.

9' (108") High Doors

- Allow taller loads to pass under the opening easily.
- Enable tighter, more complete trailer loading.
- Popular for general use with a wide range of trailer sizes.
- When servicing shorter trailers, any gap at the top can be sealed with the right dock seal or shelter.

10' (120") High Doors

- The most versatile and future-proof option.
- Accommodates virtually all trailer types, including high cube vans and containers.
- Works best with a dock shelter to ensure maximum unobstructed access and a reliable seal.

Door Widths

Most trailers on the road today are 8' to 8'6" wide. While an 8' wide door can technically service these vehicles, it offers little room for error—especially if a truck is slightly off-center—often requiring repositioning and increasing the risk of product damage.

For optimal performance and flexibility:

9' wide doors are recommended for 8'6" wide trailers.

- They allow easier side-by-side pallet loading.
- Reduce the risk of contact-related damage.
- Accommodate occasional oversized loads.

10' wide doors can be used for special applications involving wide or irregular loads but require additional building space.

To maintain efficiency and allow for dock seals, shelters, and communication lights, doors should be spaced on 12' – 14' centers.

DOCK BUMPERS: ESSENTIAL PROTECTION FOR YOUR FACILITY

Dock Bumpers

Every loading dock should be equipped with dock bumpers to protect the building and dock equipment from trailer impact. An approaching trailer can generate impact forces of up to 300,000 lbs, making proper bumper selection and placement essential to prevent costly structural damage.

Selecting the right bumper type and size helps extend the life of your dock equipment and maintain a safe, efficient operation. For specialized applications or layout constraints, consult a Blue Giant representative for tailored recommendations.

Bumper Projection

For most level approach applications, dock bumpers should have a minimum projection of 4 inches. In recessed docks or applications with declined approaches, greater projection or build-out boxes may be required to ensure full trailer contact with the bumper instead of the building.

Types of Dock Bumpers

Different bumper styles are available to meet varying operational demands:

Molded Rubber Bumpers

A solid, durable choice for standard dock operations.



Laminated Rubber Bumpers

Made from layers of recycled tire rubber, ideal for general-purpose use.

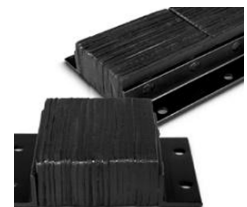

Steel Face Bumpers

Designed for high-traffic or heavy-impact applications, especially where jockey trucks are used. The steel plate face prevents excessive wear and tearing of the rubber.



WHAT IS A DOCK LEVELER?

A dock leveler is a critical piece of equipment installed at a loading dock to bridge the gap between a facility floor and the trailer bed of a truck. Since trailer heights vary and may not always align perfectly with the dock height, a dock leveler creates a smooth, adjustable transition for forklifts and pallet jacks to safely load and unload goods.

Purpose of a Dock Leveler

Bridges Height Gaps

Adjusts for the difference in height between the dock and various trailer beds.

Enables Safe Transfers

Allows forklifts and material handling equipment to move between the building and the trailer without risk.

Improves Efficiency

Speeds up loading and unloading processes, reducing downtime.

Reduces Product & Equipment Damage

Minimizes bumps and gaps that could cause load shifts or forklift wear.

Enhances Worker Safety

Provides a stable and secure path to prevent accidents and injuries during dock operations.



DOCK LEVELER SELECTION: CHOOSING THE RIGHT SIZE AND CAPACITY FOR SAFETY AND EFFICIENCY

Dock Leveler Selection

Selecting the right dock leveler involves more than just picking a standard model—it requires a careful evaluation of your facility's daily demands, trailer types, and safety standards. The goal is to match the capacity, length, and width of the leveler to your actual working conditions.

Simple Capacity Formula for Light-to-Normal Use:

$(\text{Forklift Weight} + \text{Load Weight}) \times 2.5 = \text{Minimum Capacity}$

Example:

8,000 lb forklift + 4,000 lb load = 12,000 lbs

12,000 \times 2.5 = 30,000 lb minimum leveler capacity

- For moderate to heavy usage, multiply by 3 to 4
- For high-frequency or aggressive applications, use 4 to 5

If your calculation falls between available capacities, always round up to the next available capacity class.

For a safe, reliable dock operation, each dock leveler must be tailored to the actual load conditions, equipment specifications, and vehicle types. When in doubt, consult a Blue Giant representative to ensure the right solution is selected for your dock environment.

Key Factors to Consider:

Forklift Configuration and Weight

- Include the total gross weight of the forklift and load
- Note the number, size, and type of wheels—narrow or three-wheeled vehicles create high point loads

Heaviest Load Expected

- Consider even infrequent peak loads—your leveler must be able to handle them safely

LIVE LOAD

Live Load = Maximum Forklift Weight + Maximum Forklift Lifting Capacity + Attachment Weight

Based on a maximum of 8 FTLs (fewer than 200 cycles) per day*

- W= WORKHORSE
- H= HEAVY
- S= SUPER
- E= EXTREME
- U= ULTRA

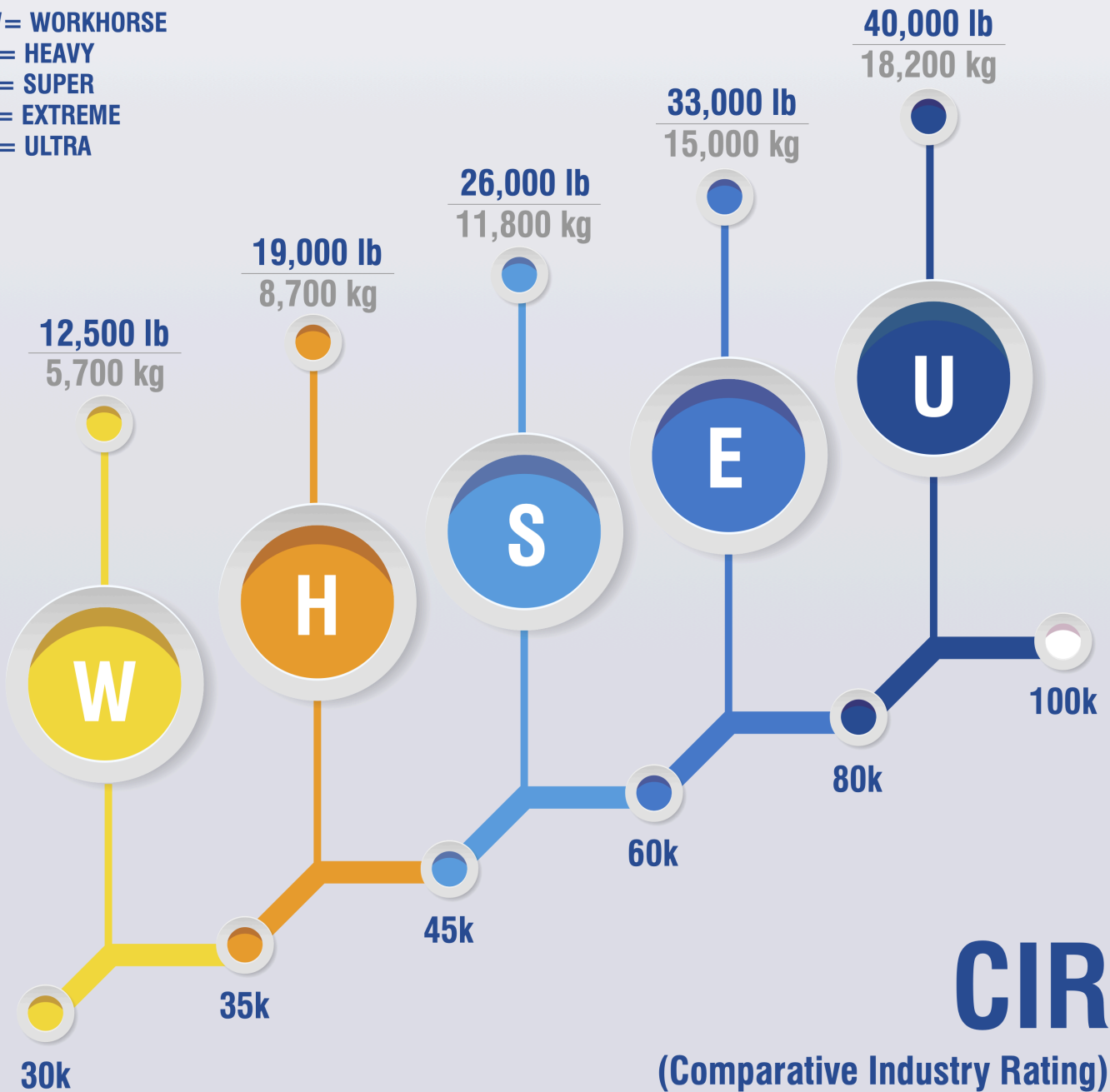

*Consult Blue Giant for other usage plans and custom applications.

© Copyright Blue Giant Equipment Corporation 2026. All Rights Reserved.

Dock-to-Trailer Height Difference

- Impacts the grade the leveler must handle

Vehicle Speed at Dock Entry

- Higher speeds dramatically increase impact forces

Daily Frequency of Use

- When selecting a dock leveler capacity, it's important to consider not just the load being carried but also how frequently the leveler will be used. The more cycles a dock leveler performs, the more stress is placed on its structural components, which gradually reduces its effective load-carrying capability. For high-traffic docks or facilities with continuous loading activity, moving up to the next capacity class ensures the leveler can safely support the required weight while also withstanding the increased frequency of use. This helps prevent premature wear, reduces maintenance issues, and ensures long-term reliability of the equipment.

WORKHORSE BLUE GIANT EQUIPMENT CORPORATION
www.bluegiant.com

MODEL / MODELE H7008W
SERIAL NO. / NO. DE SERIE 398790-01
ELECTRICS / ALIMENTATION 115V / 1PH / 60HZ
MFG / FAB 04/2018 (MM/YYYY)(MM/AAAA)

DAILY USAGE / UTILISATION HEBDOMADAIRE

TOTAL LOAD CHARGE TOTAL	FULL TRUCK LOADS / REMORQUE PLEINE			
	0-8 CYCLES / DES CYCLES	9-16	17-24	>24
4,000 lb 1,814 kg	✓	✓	✓	✓
6,000 lb 2,721 kg	✓	✓	✓	Consult / Consulter
10,000 lb 4,535 kg	✓	✓	Consult / Consulter	Consult / Consulter
12,500 lb 5,670 kg	✓	Consult / Consulter	Consult / Consulter	Consult / Consulter

10 YEAR MINIMUM LIFE EXPECTANCY / ESPERANCE DE VIE MINIMALE 10 ANS

MODIFICATIONS OUTSIDE OF THOSE OUTLINED IN PRODUCT DOCUMENTATION SHALL NOT BE PERFORMED WITHOUT THE MANUFACTURER'S WRITTEN APPROVAL. REFER TO SAFETY AND OPERATING RESTRICTIONS IN YOUR OWNER'S MANUAL. / AUCUNE MODIFICATION EN DEHORS DE CE QUI EST DECRIE DANS LA DOCUMENTATION DU PRODUIT NE PEUT ETRE FAITE SANS L'AUTORISATION ECRITE DU MANUFACTURIER. REFERER VOUS AUX INSTRUCTIONS DE SECURITE ET D'UTILISATION DU MANUEL DU PROPRIETAIRE.

COMPLIES WITH / CONFORME ANSI MH30.1 038-1082EF
MADE IN CANADA
FABRIQUE EN CANADA

Leveler Length and Safety

Dock levelers are available in standard lengths of 6', 8', 10', and 12', depending on the model and application.

Substantial height differences between dock and trailer can create extreme dock leveler grades, decreasing the overall effectiveness of the operation.

	in	2	4	6	8	10	12	14	16	18	20				
	mm	51	102	152	203	254	305	356	406	457	508				
6'/1.8m length		2.6%	5.3%	8.0%	10.7%	13.3%	(Grades exceeding 15% are considered unusable for most equipment)								
8'/2.4m length		2.0%	4.0%	6.1%	8.1%	10.1%						12.1%	14.1%		
10'/3m length		1.6%	3.3%	4.9%	6.5%	8.1%						9.8%	11.4%	13.0%	14.6%
12'/3.7m length		1.4%	2.7%	4.1%	5.4%	6.8%						8.2%	9.5%	10.9%	12.2%

Maximum grades for various material handling equipment

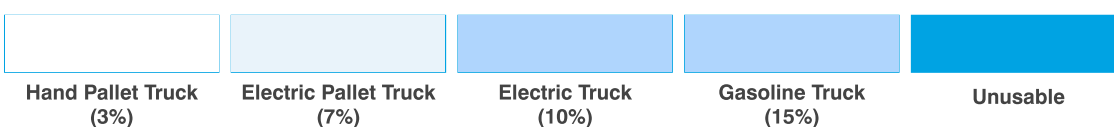

Longer levelers reduce the ramp angle (grade), which offers several advantages:

- Improved safety for forklift operators
- Reduced product spillage and equipment wear
- Increased loading efficiency
- Extended dock leveler lifespan

Tip: Longer levelers are especially beneficial when servicing high-bed or refrigerated trailers, where extra reach and clearance are required.

Leveler Width and Edge-Zone Safety

Wider dock levelers offer better protection against "edge-zone" accidents, which occur when a forklift tire travels too close to the edge and loses support. This can result in dock separation, posing serious injury risks.

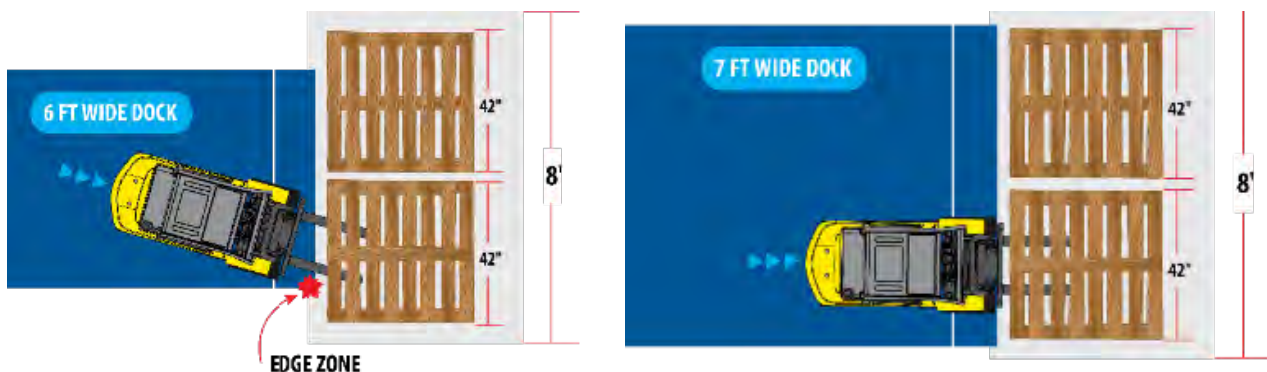

Lip Projection

Proper lip projection is critical to ensure the leveler reaches securely into the trailer bed. Factors that affect lip purchase include:

- Dock bumper thickness
- Trailer bumper depth
- Driveway slope
- Trailer bed recess

Refrigerated trailers often require longer lips to bridge the gap due to rear-end recesses or built-in insulation.

UNDERSTANDING DOCK LEVELERS: TYPES, OPERATION, AND SAFETY

Dock Levelers

Dock levelers are permanent bridging devices that allow safe and efficient transfer of goods between trailers and buildings. They must support heavy loads, adapt to trailer height variations, and ensure smooth operation—even under demanding conditions. The right dock leveler improves productivity, reduces wear on equipment, and minimizes injury risks.

Dock Leveler Types

Mechanical Dock Levelers

- Powered by springs and manually operated with a pull chain
- Lower upfront cost; no electrical hookup required
- Operate even during power outages
- Require regular maintenance and lubrication



Operation involves pulling a release chain to raise the deck and extend the lip, then “walking” the leveler down onto the trailer bed.

Common Applications: General low-traffic warehouse and distribution environments with moderate throughput and budget considerations. Also, facilities that do not want hydraulic oil in facility to contaminate product.

Hydraulic Dock Levelers

- Electro-hydraulic activation via push-button control
- Smooth operation with minimal physical effort
- Lower lifetime maintenance compared to mechanical systems
- Include hydraulic fall-safe systems for superior safety



Common Applications: High-volume facilities prioritizing speed, operator ease, and enhanced safety.

Air-Powered Dock Levelers

- Deck is raised by inflating a durable PVC-coated airbag
- Airbag is reinforced with chemical-resistant and puncture-resistant fibers
- Ideal for extreme temperature conditions and harsh environments
- Deck flexes under load, creating a smoother cross-docking transition
- Designed with easy pit cleaning and planned maintenance in mind



Common Applications: Clean operation without hydraulics; suited for applications concerned with contamination or environmental sensitivity.

Vertical Dock Levelers

- Stored in a vertical upright position, allowing the overhead door to close completely
- Enhances cleanliness, climate control, and building security
- Ideal for food, pharmaceutical, and cold storage facilities
- Deck supported by heavy-duty steel beams
- Should include a range proximity sensor to match trailer bed height and improve safety
- Designs should include a soft parking feature to reduce concrete wear and structural damage



Common Applications: Full closure of overhead door preserves interior air quality and reduces energy loss, ideal for food, pharmaceutical, and cold storage facilities.

Mechanical Dock Levelers

Mechanical dock levelers are a reliable, cost-effective solution for a wide range of loading dock applications. One of their biggest advantages is the elimination of electrical requirements—there is no need for wiring or power hookups, and they will continue to function even during a power outage. These features make mechanical levelers ideal for facilities looking to minimize infrastructure costs while maintaining operational reliability.



Operation is simple: the dock attendant pulls a release chain to disengage the hold-down mechanism, allowing the deck to lift and the lip to extend and lock into place. The operator then "walks down" the deck, guiding the lip until it rests securely on the truck bed. Once loading or unloading is complete, the same chain is pulled again (if the leveler is servicing below dock level), causing the deck to rise slightly so the lip can retract. The attendant then walks the leveler down into its stored position.

A key functional benefit of all Blue Giant mechanical dock levelers is maintained tilt. This allows the deck to "float" up or down with the movement of the trailer bed—critical for handling canted or unevenly loaded trailers. Without this feature, the lip would not stay flush with the trailer bed, which could result in product damage or strain on forklifts. Maintained tilt ensures a smooth transition and protects equipment like tires, drivetrains, and transmissions during operation.

Safety Features

Mechanical Fallsafe

Mechanical dock levelers are equipped with safety legs that prevent the deck from falling below dock height when operating in an above-dock position. These legs provide basic protection during standard use; they must be manually released for below-dock servicing. For advanced safety, especially in higher-risk environments, a hydraulic dock leveler with a hydraulic fallsafe is recommended.

Full Range Toe Guards

To eliminate potential pinch points on either side of the deck during operation, mechanical levelers can be equipped with full-range toe guards. These guards fully enclose the sides of the leveler when in a raised position. While this feature is standard on all hydraulic units, it is an important optional safety enhancement for mechanical models, especially in high-traffic or personnel-heavy dock areas.

Hydraulic Dock Levelers

Hydraulic dock levelers are an excellent choice for high-traffic, heavy-load, and demanding environments. While they typically have a higher upfront cost than mechanical units, they require significantly less routine maintenance and offer long-term advantages in performance, safety, and reliability. These levelers are particularly well-suited for facilities operating multiple shifts, using high-capacity equipment, or seeking the convenience of fully automated functionality.



Operation is simple and ergonomic. Instead of bending or pulling a chain, operators activate the unit using constant-pressure push-button controls. This reduces physical strain and speeds up dock operations. The hydraulic system raises the deck and lip with precision, ensuring a smooth transition between the dock and trailer bed.

Hydraulic dock levelers also offer advanced integration capabilities. They can be interlocked with other dock safety systems—such as vehicle restraints, overhead doors, and inflatable seals or shelters—helping to automate and secure the loading process. This ability to connect with multiple systems increases dock efficiency while minimizing the risk of accidents caused by human error.

Safety Features

Auto Return to Stored Position

This critical safety feature automatically returns the dock leveler to its stored (horizontal) position once the trailer departs. Since hydraulic levelers are downward-biased—meaning they lower by gravity—the absence of support after a truck pulls away can create a dangerous gap. Auto Return eliminates this hazard by immediately resetting the leveler to a flush position with the dock, improving both safety and workflow.

Air-Powered Dock Levelers

Air-Powered dock levelers offer a clean, low-maintenance alternative to hydraulic and mechanical models. Powered by a high-volume, low-pressure (HVLP) blower system, the airbag inflates to raise the deck and extends the lip onto the trailer bed. When the button is released, the airbag deflates, and the deck lowers gently into position.



The airbag itself is constructed with PVC-coated, chemical- and puncture-resistant fibers, making it suitable for demanding environments such as food processing, pharmaceuticals, and cold storage. With no hydraulics or springs involved, Air-Powered dock levelers reduce routine maintenance and eliminate the risk of oil leaks, making them ideal for clean, environmentally sensitive applications.

The deck is supported by structural steel beams and is designed to flex under load, ensuring smooth transitions between dock and trailer. Air-Powered levelers also feature a soft park function, which slows the deck as it returns to stored position—protecting the concrete and enhancing product longevity.

Safety Features

Full-Range Toe Guards

These fully close off the sides of the leveler when raised, eliminating pinch points and helping protect personnel during operation.

Mechanical Fall-Safe Legs

In the event of sudden air loss or trailer pull-away, integrated mechanical legs prevent the deck from collapsing below dock level.

Maintenance Support Stand

A built-in stand locks the deck in a raised position, allowing safe maintenance and inspection under the platform.

Range Proximity Sensor

Allows the deck to move in sync with the trailer bed during loading and unloading, enhancing safety and preventing trailer separation accidents.

Soft Park Feature

Slows the downward motion of the leveler when returning to stored position, reducing wear on the deck and pit and minimizing structural impact over time.

Vertical Dock Levelers

As the name implies, vertical dock levelers are stored in a vertical, upright position when not in use. This design allows overhead doors to close directly onto the concrete floor, improving climate control, cleanliness, security, and pest prevention—a key reason why vertical levelers are commonly used in food processing, cold storage, and pharmaceutical facilities.

To operate, the leveler is lowered at a controlled rate onto the trailer bed for loading or unloading. Once complete, the operator activates a control button to return the unit to its vertical position. This configuration also improves efficiency: trailers can be backed in with doors closed, then opened once positioned, eliminating the need to stop before docking.

Vertical levelers are typically available in 5' and 6' lengths, with custom lengths such as 8' available. Capacities generally range from 25,000 to 50,000 lbs, similar to conventional pit-style levelers.



Safety Features

Dual Storage Locking System

A combination of electro-hydraulic and mechanical locks ensures secure storage in the vertical position, adding an extra layer of safety when the leveler is not in use.

Emergency Stop Button

Allows the operator to immediately stop the descent of the deck if needed, providing rapid response in critical situations.

Visual Barrier Protection

When in the upright position, the leveler acts as a visible barrier, protecting overhead doors from accidental impact by forklifts or other equipment.

4" High Run-Off Guards

Commonly installed along both sides of the deck, these guards help prevent wheel roll-off during cross-docking operations, enhancing operator safety.

Easy Clean Design

The open pit or ledge-mounted configuration allows for efficient pit cleaning and sanitation, an essential requirement in hygiene-sensitive environments.

Edge of Dock Levelers (EODs / Mini Dock)

Compact, practical, and cost-effective, Edge of Dock Levelers (EODs)—also known as Mini Docks—are an excellent solution when trailer bed heights vary only slightly from the dock height. Unlike recessed pit-style dock levelers, EODs mount directly to the face of the dock and anchor into a steel curb channel embedded in the concrete, making them easier and more affordable to install.

EODs are ideal for lower-volume loading environments where a full-size dock leveler is not necessary. They safely bridge the gap between the dock and trailer but are best used in applications with a height difference of no more than ± 2 inches. Using EODs outside of this range may result in unsafe loading conditions and reduced efficiency.

Note: If manual pallet jacks or carts are used, the trailer bed should be level with the dock. Even small height variations can make product transfer difficult with manual equipment

There are two main activation methods for EODs, each designed for specific operator needs:

Mechanical EODs are activated manually. The operator pulls the handle to lift the deck and lip into position. The lip then lowers onto the trailer bed. Once loading is complete, the unit retracts behind the dock bumpers.



Hydraulic EODs are activated using a simple push-button control. The unit raises automatically and then settles onto the trailer bed. After use, it returns to its stored position at the push of a button.



Capacity and Sizing Options

EODs are available in standard capacities up to 30,000 lbs, suitable for many light to medium-duty loading environments.

Common widths include:

- 66" wide – the most commonly specified width
- 72" wide – offers more flexibility for wider loads or equipment
- 78" wide – used when wider trailers or pallet configurations require more space

Selection of width should be based primarily on the product type, handling equipment, and loading method.

OPTIONAL FEATURES FOR ENHANCED DOCK LEVELER PERFORMANCE

Optional Dock Leveler Features

Selecting the right dock leveler is only the beginning—enhancing it with the right optional features ensures maximum efficiency, safety, and long-term performance. The following upgrades can be tailored to meet your facility's specific needs:

Enhancing your dock leveler with the right options not only extends its service life but also ensures it performs to your operational and environmental requirements. For help tailoring your equipment to your facility's needs, consult with your authorized Blue Giant representative.

Galvanized Finish

Hot-dip galvanizing offers maximum corrosion protection. Each component is galvanized before assembly, ensuring full coverage.

Ideal for:

- Food processing facilities
- Chemical handling plants
- Coastal environments with salt exposure

Clean-Pit Designs

Where hygiene is a priority, a clean-pit dock leveler allows full wash-down access. These units are designed without a frame assembly, ensuring easy, complete cleaning of the pit.

Another option is the open-pit, self-supporting design, which is cast directly during pit construction to eliminate hidden or hard-to-reach areas.

Common in: pharmaceutical, food, and beverage industries.

Extended Lip Length

Standard dock levelers are equipped with a 16" lip, which is suitable for most applications. However, for specialized needs, extended lips of 18" to 20" or more are available—especially on hydraulic models.

Use extended lips when:

- Dock bumpers project more than 4"
- There is a significant height difference between dock and trailer

Refrigerated trailers often have internal beds recessed behind a step. Without a long enough lip, the dock leveler will rest on the step instead of the load surface—causing rough transitions and potential damage.

A properly sized lip ensures smooth, direct access to the internal bed for efficient and safe loading.

Side / Rear Weather Seal

To improve climate control and reduce air infiltration, dock levelers can be fitted with:

- Neoprene strips along the sides and rear
- Brush seals, ideal where rodent control is also a concern

Foam-Insulated Deck

- A spray-applied foam insulation layer on the underside of the deck helps maintain temperature control by preventing the deck from condensing moisture due to warm or cold air transfer.
- Recommended for cold storage, temperature-sensitive facilities, and energy-efficient buildings.

DOCK LEVELER INSTALLATION STYLES: CHOOSING THE RIGHT FIT FOR YOUR PROJECT

Dock Levelers

Dock levelers can be installed using three primary methods—Preformed Pit, Blue Giant Pit Kits: The Hybrid Solution or Pour-in-Place—depending on project timeline, site conditions, and budget. Both methods are compatible with hydraulic, mechanical, and airbag levelers.

Choosing the right installation method depends on your construction schedule, cost constraints, and long-term performance needs. For personalized guidance, contact a Blue Giant representative to determine the best option for your facility.

Installation Styles

Preformed Pit Installation

This is the most common installation method, where a concrete pit is formed ahead of time to match the dimensions of the selected dock leveler.

Advantages:

- Pits are created during the initial construction phase, keeping the project on the general contractor's schedule
- Compatible with a wide range of dock leveler sizes and models
- Lower initial equipment cost compared to pour-in-place units

Blue Giant Pit Kits: The Hybrid Solution

To combine the best of both methods, Blue Giant Pit Kits provide prefabricated steel panels that are assembled on-site, forming a precise, square pit without the need for traditional wood forming.

Benefits of Pit Kits:

- Faster and more accurate pit formation
- Lower cost than traditional wood forms
- Ensures a true square fit for optimal leveler performance
- Compatible with any Blue Giant dock leveler

Considerations:

- Longer installation time due to the need for pit forming and preparation
 - Higher total installed cost because of additional labor and materials
 - Requires proper curb angles for anchoring and support
-

Pour-in-Place Installation

With this method, the dock leveler is positioned before the floor slab is poured. A notch is created in the foundation wall, and the leveler is set in place and secured to a prepared concrete pad.

Advantages:

- Faster installation and reduced overall labor cost
- Can be integrated into the building's construction schedule
- Offers strong structural support when anchored to the poured pad

Best For: New builds where dock levelers can be installed early in the construction process

SECURING THE DOCK: VEHICLE RESTRAINT SYSTEMS AND THEIR ROLE IN SAFETY

Vehicle restraints

Vehicle restraints are essential for preventing one of the most dangerous scenarios at the loading dock: a forklift accident caused by premature trailer departure or vehicle creep. In high-traffic facilities, each dock position can face dozens—if not hundreds—of risk opportunities daily.

The most common type is the face-mount vehicle restraint, which engages with the trailer's ICC bar to secure it firmly in place. This system plays a critical role in ensuring both operational safety and efficiency by:

- Preventing premature departure of trailers during loading/unloading
- Limiting vehicle creep that occurs from trailer movement over time
- Keeping the extended dock leveler lip in place on the trailer bed
- Acting as a deterrent against trailer theft

Key Considerations

- **Restraint Capacity:** Most models offer 35,000 lbs. of pull-away resistance, providing robust holding force even under aggressive conditions.
- **Operating Range:** Standard face-mount restraints accommodate trailer ICC bars within 12" to 30" from the dock surface. Custom options are available for unusually low or high trailer bars.
- **Adaptability:** Look for units with flexibility to adapt to a wide variety of trailer configurations and ICC bar shapes.
- **Durability:** Vehicle restraints are installed in one of the harshest environments on-site—exposed to water, debris, and impact—so rugged construction is critical.
- **Recessed Models:** Though less common, pit-mounted vehicle restraints are available and store beneath the dock leveler. While they offer a concealed solution, they also require additional pit construction costs.

Types of Vehicle Restraints

Vehicle restraints come in a variety of types, each offering a different method of operation to suit specific facility needs. The most common are face-mount vehicle restraints, which can be operated using either electro-mechanical or electro-hydraulic systems. These powered units automatically position the restraining arm to engage the trailer's ICC bar and are typically preferred in high-volume or automation-focused environments.

Alternatively, manual vehicle restraints are available for facilities looking for a more economical solution. These restraints are positioned by the dock attendant using a metal bar to manually engage and disengage the restraining mechanism. Regardless of the type, the most critical factor is ease of use. A vehicle restraint that is intuitive and simple to operate is more likely to be used correctly and consistently by dock personnel, ultimately enhancing overall dock safety.

Face-mount restraints are also highly valued for their easy installation and maintenance. Since they are mounted externally to the dock face, they are not only accessible for service but also readily relocatable should the need arise.

One example of a manual restraint is the Blue Giant ML10, which features a rugged, structural design and requires no electrical connections. The ML10 is easy to operate, simple to install, and provides an effective, cost-efficient solution to improve safety at the loading dock.



Mechanical Vehicle Restraints

Mechanical vehicle restraints offer a durable, cost-effective solution to enhance safety at the loading dock. These systems are specifically designed to prevent premature vehicle departure, minimize trailer creep, and maintain consistent contact between the trailer and the dock leveler during loading and unloading.

One of the key advantages of mechanical restraints is their simplicity of operation.

For example, the Blue Giant ML10 mechanical vehicle restraint features a manual activation system. A dock attendant uses an engagement bar to raise the restraining arm into position, locking onto the trailer's Rear Impact Guard (RIG). Once loading is complete, the same bar is used to disengage and return the restraint to its stored position.

The ML10 is engineered for rugged performance, constructed from high-strength steel components to withstand harsh dock environments. It provides a restraining force of up to 30,000 lbs, helping to ensure trailer stability even under demanding conditions. Because it requires no electrical connections, the ML10 is ideal for facilities seeking a low-maintenance, reliable restraint option without the added complexity or cost of powered systems.

In addition to its functionality, the ML10 offers easy installation and relocation. It mounts directly to the dock face and can be integrated into new or existing docks with minimal disruption. This makes it a popular choice for both retrofit and new construction projects.

By choosing a mechanical vehicle restraint like the ML10, facilities can achieve a higher level of dock safety without sacrificing operational simplicity or long-term durability.



Electric Vehicle Restraints

Electric vehicle restraints offer a reliable and user-friendly solution to secure trailers at the loading dock, significantly reducing the risk of trailer separation accidents. These restraints are designed to engage the Rear Impact Guard (RIG) of the trailer automatically, providing up to 32,000 lbs. of restraining force, and ensuring that the trailer remains securely positioned throughout the loading or unloading process.



Blue Giant's electric vehicle restraints, such as the StrongArm™ HVR303, are equipped with an electro-mechanical drive system that efficiently moves the restraining arm into place. The operation is fully automated and controlled by a push-button panel, making the system simple and intuitive for dock personnel. A key safety feature is the built-in LED communication system, which signals the restraint's status to both the forklift operator inside the facility and the truck driver outside—minimizing communication errors and enhancing dock safety.

These restraints also feature a standard bypass switch that allows manual override in special cases, and a low-profile housing that accommodates a wide range of trailer designs, including those with damaged or non-standard RIGs. With a service range between 9" and 25" off grade, Blue Giant electric restraints provide the flexibility needed to handle varied trailer heights.

Durability is built into the system, with a rugged steel construction that withstands harsh environmental conditions at the dock. Designed for low maintenance, the electric drive system requires no hydraulic components, simplifying both initial setup and long-term servicing.

For facilities seeking a high-performance, low-maintenance vehicle restraint solution with enhanced safety communication and easy operation, Blue Giant's electric models provide a robust and effective choice.

Hydraulic Vehicle Restraints: Powered Performance for Dock Safety

Hydraulic vehicle restraints are designed to secure a trailer's rear impact guard (RIG) to the loading dock using a powerful electro-hydraulic system. These restraints are ideal for high-volume, fast-paced loading environments where safety, reliability, and automation are priorities.

Blue Giant's hydraulic restraints offer a restraining force of up to 32,000 lbs., preventing trailer separation during loading and unloading. The hydraulic system ensures consistent and reliable operation, regardless of weather or trailer condition.



Key features of hydraulic vehicle restraints include:

- **Automatic Activation:** The operator uses a push-button control panel to deploy and store the restraining arm, reducing physical strain and simplifying operation.
- **Wide Operating Range:** Most models engage RIGs located from 9" to 30" above ground, accommodating a broad range of trailer heights and conditions.
- **Integrated Communication System:** Bright red and green LED traffic-style lights provide clear visual communication to both dock workers and truck drivers, enhancing awareness and safety.
- **Heavy-Duty Steel Construction:** Designed to withstand harsh weather and demanding applications, hydraulic restraints feature corrosion-resistant components and robust mounting hardware.
- **Interlock Capability:** Easily integrates with other dock equipment—such as levelers and overhead doors—ensuring the restraint cannot be operated unless all safety criteria are met.

Hydraulic vehicle restraints are particularly well-suited for distribution centers, food-grade facilities, and pharmaceutical operations, where secure trailer engagement and automation improve both safety and efficiency. Their low maintenance needs and long-term durability make them a smart investment in any high-performance loading dock system.

Wheel Chocking Systems: Safety Beyond the RIG Bar

Not all trailers come equipped with functioning RIG bars, and in such cases, traditional restraints may not be effective. Blue Giant's Wheel Chocking Systems, including the advanced Interlock Chock®, provide a reliable, intelligent alternative by securing the trailer at the wheel. These systems are particularly useful in environments where trailer creep, premature departure, or damaged RIG bars are concerns. With seamless integration into dock safety systems, the Interlock Chock® improves communication, efficiency, and overall safety at the loading dock.



The Interlock Chock® offers a host of smart features and rugged reliability:

Durable Construction

Built with an aluminum chock and a stainless-steel sawtooth plate that grips the pavement, it ensures solid contact with the wheel even in adverse weather.

Advanced Sensing & Controls

Equipped with ultrasonic sensors to detect wheel placement and proximity sensors to verify when the chock is stowed, the system reduces operator error and enhances automation.

High-Visibility Communication

LED lights and an integrated alarm on the chock handle provide clear visual and audible signals to both dock personnel and drivers.

System Integration

Fully compatible with Blue Genius® controls, LED dock lights, and traffic signal systems to manage safe loading sequences.

This system is ideal for facilities handling trailers of varying sizes and conditions, especially where RIG bars may be missing or inconsistent. By reducing reliance on trailer hardware and integrating with dock controls, Blue Giant's Interlock Chock® offers a proactive solution to one of the most overlooked safety risks at the dock.

SMART DOCK CONTROLS: SIMPLIFYING SAFETY AND EFFICIENCY

Smart Controls

Modern loading docks demand intelligent, easy-to-use controls that enhance safety, improve workflow, and reduce downtime. Blue Giant's line of dock control panels integrates dock levelers, vehicle restraints, and overhead doors into centralized, intuitive systems. Designed for reliability and ease, our control panels streamline dock operations while supporting compliance and performance at every turn.

Smart Integrated Dock Control System

Advanced controls that combine several dock functions (levelers, restraints, doors, lights). Offers interlocking capabilities and sequencing to enforce safety protocols and reduce human error.



Touch Based Control Panel

The Blue Genius® Series I, II, and III control panels provide advanced, centralized control for loading dock equipment. Designed for safety, efficiency, and ease of use, these intuitive interfaces streamline dock operations by integrating multiple functions into one reliable platform. Whether managing dock levelers, vehicle restraints, overhead doors, or other devices, the Blue Genius® line offers flexible control options to suit a wide range of facility needs.



Single Push-Button Control

Simple and reliable. Operates one piece of equipment—ideal for basic hydraulic levelers or vehicle restraints. Cost-effective solution for facilities with limited equipment integration.



SEALS & SHELTERS: ENHANCING EFFICIENCY, SAFETY, AND PROTECTION AT THE DOCK

Seals & Shelters

Dock seals and shelters are essential components for maintaining internal facility climate, improving safety, and protecting goods during loading and unloading. By forming a seal between the building and the trailer, these systems minimize energy loss, enhance security, and contribute to a cleaner, more efficient loading dock environment.

For most level approach applications, dock bumpers should have a minimum projection of 4 inches. In recessed docks or applications with declined approaches, greater projection or build-out boxes may be required to ensure full trailer contact with the bumper instead of the building.

Key Benefits

- **Energy Savings:** Reduces heating and cooling costs by maintaining temperature control.
- **Improved Safety:** Keeps out rain, snow, and debris, minimizing slip hazards and ensuring safer working conditions.
- **Product Protection:** Shields goods from weather elements and deters rodents and insects from entering the facility.
- **Enhanced Security:** Helps prevent unauthorized access and reduces theft risks during loading operations.
- **Operational Efficiency:** Improves dock environment, boosts employee comfort, and increases productivity.
- **Fast ROI:** Energy savings can pay back the cost of seals/shelters in just months.
- **Expanded Storage:** Sealed trailers can act as temporary, secure storage extensions of the facility.

Dock Seals & Shelters

Selection Considerations

Proper selection is critical to ensure an effective seal and long-term performance. The following criteria should be evaluated for each facility:

Truck & Dock Configuration

- Trailer width and height
- Truck bed height and bumper projection
- Consistency or variability in trailer sizes

Dock Setup

- Dock height from finished grade
- Dock bumper projection (especially important on declined approaches)
- Size of the overhead door
- Wall strength and type for mounting

Approach Grade

- Level, inclined, or declined approaches require custom tapering for an optimal seal

Size Guidelines

- **Seals:** Ideal for 8' wide doors; side pads can be beveled to adapt to varying widths
- **Shelters:** Typically used on 9'–12' wide and high doors; ensure a reduced inside seal opening of ~90" x 90"
- **Common Trailer Size Assumption:** 13'-6" high trailers, 96"–102" wide
- **Projection:**
 - Seals: Should allow 4"–6" of compression before trailer contacts the bumper
 - Shelters: Should project 18"–24" for proper trailer entry



Compression Dock Seals

Compression dock seals are one of the most effective solutions for sealing the gap between a trailer and a loading dock. As a trailer backs into the dock, it compresses durable foam-filled side and head pads, creating a tight seal that helps maintain internal climate control, protect goods, and improve safety and energy efficiency.



Key Benefits:

- **Energy Savings:** Minimizes heating/cooling loss by sealing around the trailer opening.
- **Product Protection:** Prevents contamination from wind, rain, and debris.
- **Safe and Clean Work Areas:** Keeps docks dry and reduces slip hazards.
- **Built to Last:** High-density foam and wear-resistant fabrics ensure long-term durability.
- **Custom Fit:** Tapered and custom-sized pads available for declined or unique approaches.

Seal Options Available:

- **Standard Compression Seals:** Best for consistent trailer sizes and standard dock heights.
- **Tapered Seals:** Designed for declined driveways to ensure even compression.
- **Beveled Pads:** Ideal for wider doors or tighter seal requirements.
- **Head Curtain Seals:** Accommodate varying trailer heights while maintaining a tight seal.

Blue Giant's compression seal systems offer a simple, effective solution that improves energy efficiency, security, and productivity at the dock.

Dock Shelters

Dock shelters are designed to create a protected passageway between the building and trailer, forming a flexible enclosure that allows unrestricted access to the full truck opening. Unlike compression seals, which rely on foam contact, shelters use fabric curtains that form a seal around the trailer sides and top — making them ideal for servicing a wide range of trailer sizes and door configurations. They are especially well-suited for high-traffic docks where trailer heights and widths vary.



Key Benefits:

- **Versatile Fit:** Accommodates a wide range of truck and trailer sizes.
- **Unobstructed Access:** Allows full-width entry to the trailer without foam compression.
- **Weather Protection:** Shields dock and goods from rain, wind, and debris.
- **Improved Safety:** Keeps the dock area dry and helps prevent slips and falls.
- **Energy Efficiency:** Helps maintain facility climate by minimizing air exchange during loading/unloading.

Shelter Options Available:

- **Rigid Frame Shelters:** Sturdy and durable, with fixed side and head frames for consistent performance.
- **Soft Sided Shelters:** Use flexible side frames to absorb impact and reduce damage from off-center trailers.
- **Adjustable Head Curtains or Panels:** Adapt to different trailer heights for a more effective seal.

Blue Giant dock shelters are built with durable materials and customizable features to enhance dock protection, reduce energy costs, and improve loading dock productivity.

Inflatable Dock Shelters

Inflatable dock shelters are a premium sealing solution designed for maximum flexibility, energy efficiency, and protection. Unlike foam compression seals or rigid shelters, inflatable models deploy air-inflated chambers that expand around the trailer after it is backed into position. This creates a tight, custom seal that minimizes gaps —ideal for temperature-sensitive environments and facilities handling diverse trailer types.



Key Benefits:

- **Superior Seal:** Inflates to conform tightly around trailer sides and top, reducing air loss and keeping out the elements.
- **Energy Efficiency:** Helps maintain interior temperatures, making them ideal for cold storage and climate-controlled facilities.
- **Full Access:** Allows unrestricted access to the entire trailer width and height for efficient loading/unloading.
- **Durability:** Made with high-strength fabrics and components to withstand frequent use and harsh environments.
- **Low Wear:** Retracted during trailer positioning to avoid damage from misalignment or off-center approaches.

Ideal Applications:

Food processing, cold storage, pharmaceuticals, and high-volume logistics centers requiring dependable environmental control.

Blue Giant's inflatable dock shelters are available in various configurations to match door sizes, traffic volume, and trailer types, providing a reliable and long-lasting sealing solution.

ELEVATING DOCKS: FLEXIBLE GROUND-TO-TRAILER SOLUTIONS

Dock Lifts

Elevating docks, also known as dock lifts, provide a versatile and efficient way to manage vehicle height differences at the loading dock. Designed to lift loads from ground level to trailer height, these hydraulic platforms are ideal for facilities without standard dock height access or where a wider range of vehicle sizes are serviced.



Design and Installation

- Typically pit-mounted within a three-sided recessed area of the dock wall.
- Can also be installed at the dock face, though this may create an obstruction in tighter spaces.

For increased efficiency, wide-deck units support side-by-side pallet loading, minimizing lift cycles.

Key Selection Considerations

1. Deck Size

- Ensure the deck is large enough to accommodate turning radius, vehicle size, and load configuration.
- Common sizes range from 72" x 96" to 96" x 144".
- 84" wide decks accommodate a 75" turning radius.
- 96" wide decks support side-by-side pallet loading for greater efficiency.

2. Lifting Capacity

- Must lift the entire gross weight of the forklift and load — no dynamic load consideration as in dock levelers.
- For frequent use (e.g., 20+ cycles/day), consider overrating capacity to increase longevity.
- Available capacities range from 3,000 lbs to 25,000+ lbs.
- Be sure to consider axle loading: some vehicles carry 80% of gross load on a single axle.

3. Lifting Speed

- Speed depends on platform size, capacity, and power pack horsepower.
- Aim for a 20–30 second lift time for optimal productivity.
- Specify both lift and lower times during selection to balance cost and performance.

COMPLETING THE DOCK: ACCESSORY PLANNING & INTEGRATION FOR SAFETY & PRODUCTIVITY

While primary dock equipment such as levelers, vehicle restraints, doors, and seals form the foundation of a loading dock system, the overall performance of the dock is impacted by the components that support it. Accessory elements play a critical role in enabling the system to operate safely, efficiently, and consistently under real-world conditions. These components protect the building structure, guide trailer movement, reduce impact, improve visibility, and support safe operator interaction at the point of loading and unloading.

When integrated early in the design process, accessories enhance system performance, improve operational efficiency, and reduce long-term risk. Rather than functioning as individual add-ons, they ensure the dock operates as a complete, coordinated system—designed to meet the demands of daily use.

Understanding the Role of Accessories

Accessories are not standalone add-ons. They support infrastructure that connects and enhances primary equipment.

A well-equipped dock position typically incorporates:

Impact Protection Solutions - The first line of defense at the dock face.

These systems are designed to absorb and redirect the forces generated when trailers make contact with the building or to help decrease building/door damage from moving equipment within the facility. Without proper protection, repeated impacts can lead to structural damage, premature equipment wear, and increased maintenance costs.

Typical accessory components include dock bumpers, bollards, door track guards, and structural reinforcements.



Vehicle Guidance Solutions - Consistent trailer positioning is critical to safe and efficient dock operation.

Guidance systems assist drivers in aligning trailers correctly during approach, reducing the risk of off-center impacts, seal damage, or improper engagement with dock equipment.

Typical accessory components include wheel guides or reflective guides to improve repeatability at each dock position—minimizing variability and supporting smoother, faster docking.

**Safety & Fall Protection Systems - Open dock doors present a significant safety risk when a trailer is not present.**

Fall protection systems are designed to safeguard personnel and equipment by creating both physical and visual barriers at the dock edge. These systems help prevent accidental forklift roll-offs while also controlling access to active dock positions.

Dock gates, barrier systems, and protective posts reinforce safe behavior and play a critical role in reducing workplace incidents.

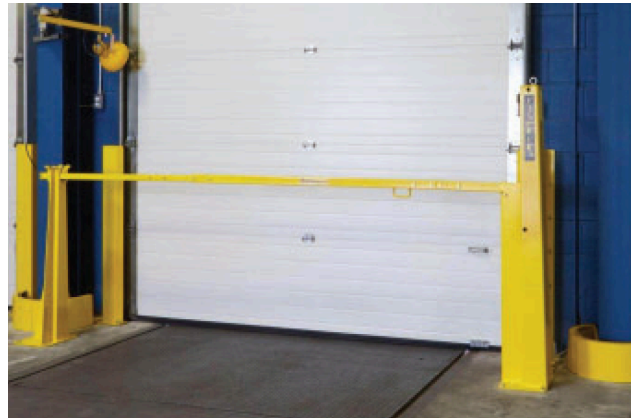

Lighting, Visibility & Communication - Clear visibility and communication are essential at every stage of dock operation.

Lighting systems illuminate trailer interiors, improving accuracy and reducing strain on operators. Communication systems—such as interior and exterior signal lights—help coordinate safe interaction between dock personnel and drivers.

When integrated properly, these systems reduce human error, improve workflow, and enhance overall safety at the dock.



Environmental & Energy Control - Even well-designed docks can lose energy and allow contaminants to enter through small gaps.

Environmental accessories are designed to seal these openings, improving temperature control, cleanliness, and operational efficiency. These systems help maintain internal conditions while reducing energy loss and protecting sensitive goods.

They are especially important in temperature-controlled, food-grade, and clean environments where consistency is critical.



Trailer Stabilization & Backup Safety - Securing the trailer is essential—but redundancy ensures safety.

Supplemental stabilization systems provide an additional layer of protection against trailer movement, particularly in situations where primary restraints cannot be used or conditions are variable.

Wheel chocks, trailer stands, and support devices help reduce the risk of trailer separation, reinforcing a safer and more controlled loading environment.



Overhead & Weather Protection - Dock openings are constantly exposed to weather, which can impact both safety and productivity.

Overhead protection systems, such as canopies, help shield dock positions from rain, debris, and environmental exposure. This improves working conditions, protects product during transfer, and reduces weather-related disruptions.

These systems are particularly valuable in open or exposed dock configurations.

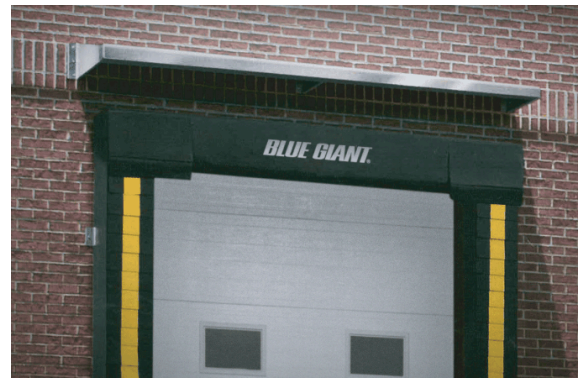

Each component plays a specific role—but their real value is realized when they are planned and implemented as part of a complete dock strategy.

From Oversight to Optimization: Integrating Dock Accessories

In many projects, accessory components are identified in specifications but not fully coordinated during the design phase. They are often deferred to later stages, left to field decisions during installation, or treated as optional budget items. This can lead to unplanned site modifications, increased installation time and costs, and gaps in safety coverage—particularly around fall protection and trailer movement. It may also result in premature wear on equipment and inconsistent workflows for operators and drivers. What may seem like a minor omission during design can quickly develop into a recurring operational issue that impacts both safety and efficiency.

High-performing facilities take a different approach by designing the dock as a fully integrated system from the outset. Accessory requirements are evaluated alongside dock layout, traffic patterns, trailer types, approach conditions, and overall facility demands. By incorporating these elements early in the planning process, projects benefit from more coordinated installation, improved protection for the building and equipment, safer and more intuitive operation, and reduced long-term maintenance costs. In this context, accessories should be treated with the same level of importance as primary equipment—not as secondary items, but as performance enablers that reinforce safety, extend equipment life, improve efficiency, and reduce overall operational risk.

WHERE STANDARDS MEET STRENGTH: THE BLUE GIANT ADVANTAGE

Why This Matters to You

When you choose Blue Giant, you're selecting a partner who prioritizes real-world performance, long-term reliability, and safety. Their compliance with global and regional standards ensures that every piece of equipment is built to:

- Protect people and assets through UL and CE certifications
- Last longer and perform better with PCI-certified coatings and rigorous structural design
- Improve efficiency and reduce injury risk through ergonomic design principles promoted by EASE and MHI collaborations

How Blue Giant Ensures Ongoing Compliance

From concept to installation, Blue Giant integrates these standards into every step of the product lifecycle. All equipment is:

- Designed and tested to meet or exceed UL, ANSI, and CE requirements
- Manufactured using audited and certified processes, including PCI 4000-compliant finishing systems
- Backed by professional oversight, with licensed engineers and AWS-certified welders overseeing production
- Refined through industry collaboration, ensuring solutions align with current needs and anticipate future demands

Quality Assurance & Certification

Blue Giant is committed to producing equipment that meets the highest safety and performance standards. Our products meet the standards outlined by Underwriters Laboratories (UL), ensuring electrical and operational safety.

Adherence to American National Standards Institute (ANSI) guidelines further reflects a dedication to voluntary, consensus-based manufacturing standards that emphasize quality and consistency.

With CE Marking, Blue Giant ensures compliance with strict European Union safety and environmental directives, making our products globally accepted.

Additionally, Blue Giant holds PCI 4000 certification for powder coating, meaning every unit is finished with durability and corrosion resistance in mind.

Industry Association Participation

Blue Giant plays an active role in shaping the future of material handling through membership in key industry groups under Material Handling Industry (MHI). This includes participation in:

LODEM (Loading Dock Equipment Manufacturers), which sets industry-wide safety and performance standards for dock equipment. LIFT Manufacturers Group, focusing on innovation and safe design for lift systems. EASE (Ergonomics Assist Systems & Equipment), which promotes safer, more comfortable, and efficient work environments.

Through these affiliations, Blue Giant stays ahead of evolving safety regulations and engineering best practices, ensuring our solutions are modern, reliable, and worker-focused.

Professional & Technical Credentials

Blue Giant's engineering and production processes are guided by certified professionals and top-tier standards. The company employs licensed engineers accredited by Professional Engineers Ontario (PEng), ensuring all designs meet regulated engineering principles. Welders are certified through the American Welding Society (AWS), delivering precision and strength in structural fabrication. Blue Giant also supports the continuing education of architectural professionals through AIA/CES (American Institute of Architects - Continuing Education Systems), fostering a stronger integration of their products into architecturally sound, high-performance facilities.



MASTER SITE SURVEY

When you choose Blue Giant, you're selecting a partner who prioritizes real-world performance, long-term reliability, and safety. Their compliance with global and regional standards ensures that every piece of equipment is built to:

- Protect people and assets through UL and CE certifications
- Last longer and perform better with PCI-certified coatings and rigorous structural design
- Improve efficiency and reduce injury risk through ergonomic design principles promoted by EASE and MHI collaborations

DATE: _____

SITE DATA

COMPANY:	NAME:	ADDRESS:
COUNTRY:	CITY:	STATE / PROVINCE:
CONTACT:	CONTACT'S EMAIL:	NUMBER OF POSITIONS / BAYS:

REPORTER DATA

NAME:	EMAIL:	COMPANY:
-------	--------	----------

DIRECTIONS

1. Please complete all questions applicable to the installation configuration. Failure to supply required information may result in a delay in your order processing. Survey information must reflect site conditions at the time of installation.
2. For multiple positions / bays: If site conditions are not identical for each position / bay, please fill out a separate site survey form.
3. To ensure accurate order processing, please use decimals instead of fractions when supplying dimensions and other measurements (for example 1/2" should be .50").
4. Use either imperial (e.g. lb, in) or metric (e.g. kg, mm) units of measurement consistently throughout the document.

NOTES

1. Dock Seals and Shelters

Dock Seal and Shelter Site Conditions - Project Photo Required

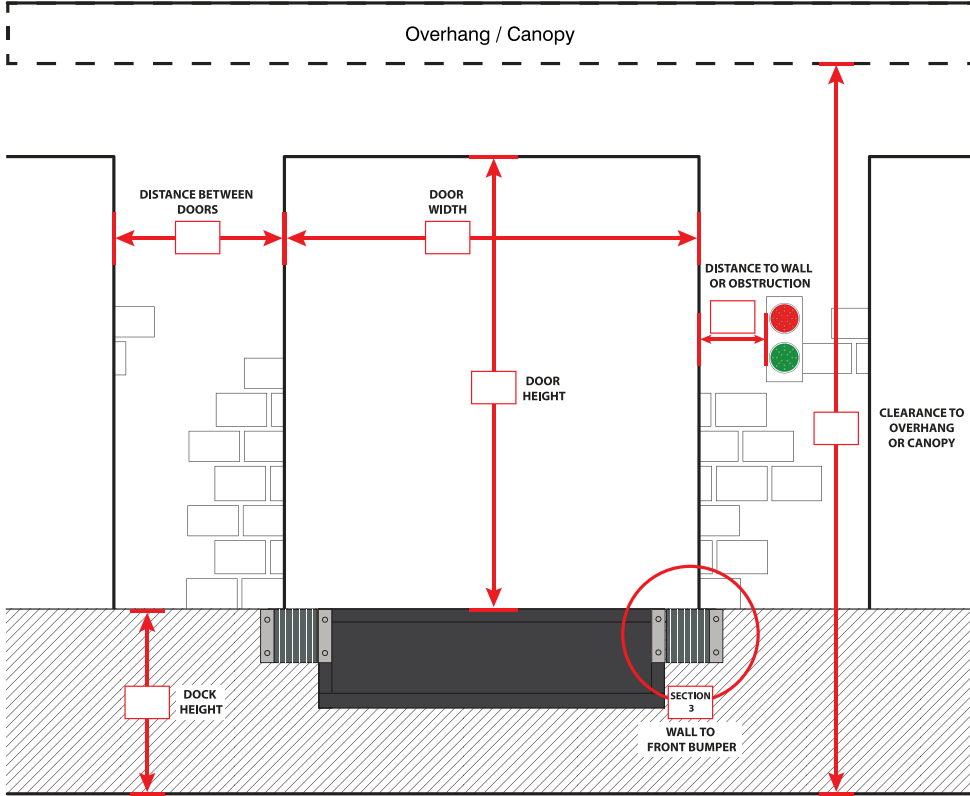

BUILDING WALL TYPE

MASONRY
 METAL
 CONCRETE
 DESCRIBE:

MOUNTING SURFACE

MASONRY
 METAL
 CONCRETE
 DESCRIBE:

MOUNTING SURFACE CONDITION

EVEN
 UNEVEN
 DESCRIBE:

NOTES

For more information on “Wall to Front Bumper” measurement, see Section 3 “Grade and Bumper”

2. Loading Dock Details

Pit Style -Required dimensions are outlined in RED in the diagram below. Please fill in completely.

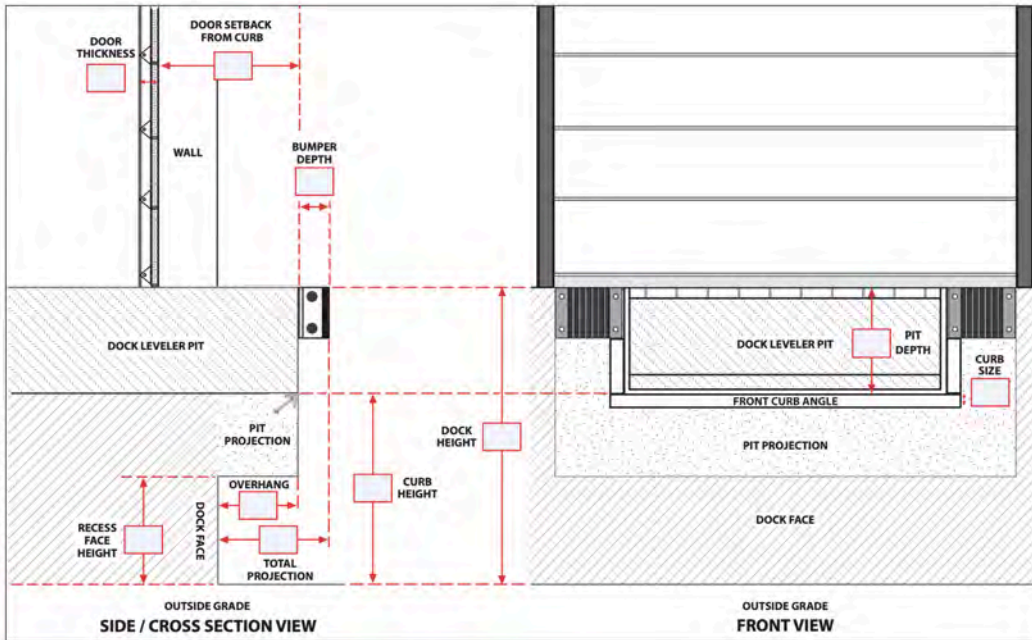

PIT DIMENSIONS

STANDARD PIT DEPTH	Front (H) 20" (508 mm)	
	Rear (H1) 19.5" (495 mm)	
PIT TO DECK WIDTH	$W \text{ (pit)} = W \text{ (deck)} + 2" \text{ (51 mm)}$	
PIT TO DECK LENGTH	$L \text{ (pit)} = L \text{ (deck)}$	
H	H1	W
L	S1	S2

DOCK FACE / RESTRAINT MOUNTING SURFACE

DESCRIBE (E.G. CONCRETE*, BRICK, ETC.)

PIT SQUARE WITHIN .25" (6 mm)

- YES NO

CONCRETE CONDITION

- GOOD FAIR POOR

CURB ANGLE CONDITION

- GOOD FAIR POOR

CURB ANGLE CONFIGURATION (PIECES)

- FOUR SIX EIGHT



*Concrete must be minimum 8" (203 mm) thick.

Vertical Storing Dock Leveler -Required dimensions are outlined in RED in the diagram below. Please fill in completely.

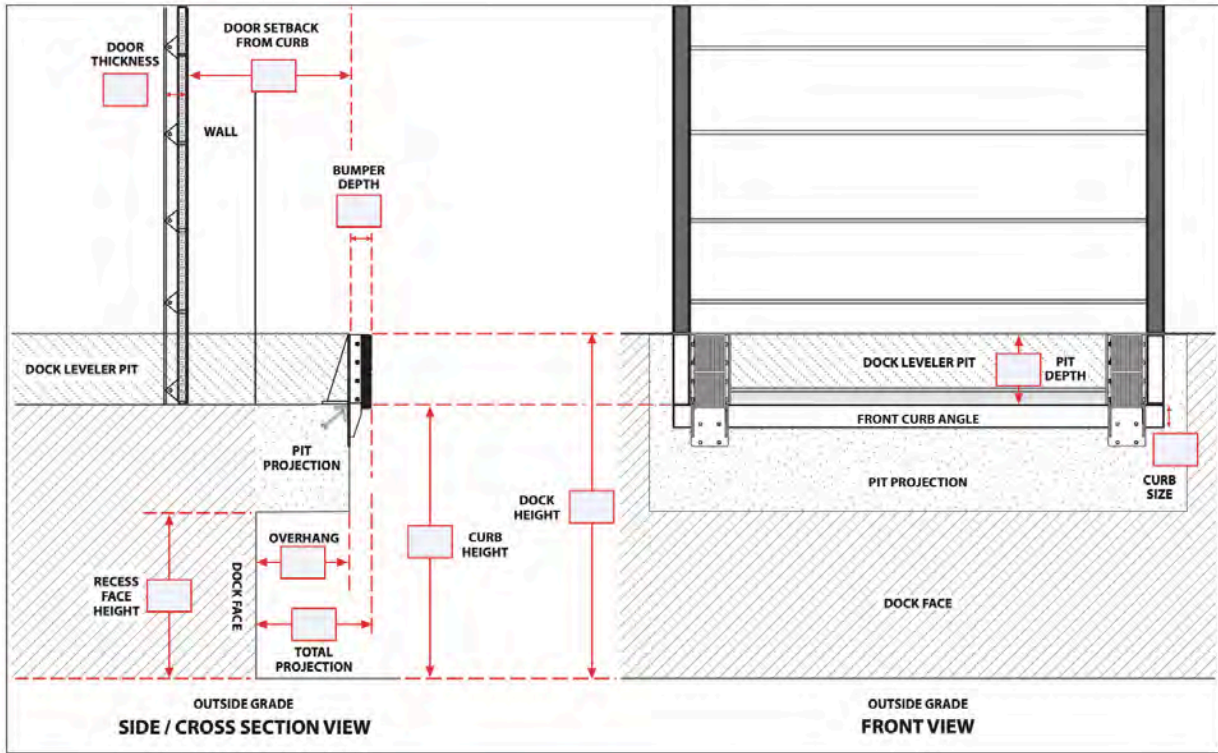

PIT DIMENSIONS

STANDARD PIT DEPTH	Front (H) 12.5" (318 mm)		
	Rear (H1) 12" (305 mm)		
PIT TO DECK WIDTH	$W \text{ (pit)} = W \text{ (deck)} + 2" \text{ (51 mm)}$		
PIT TO DECK LENGTH	$L \text{ (pit)} = L \text{ (deck)}$		
H	H1	W	L

DOCK FACE / RESTRAINT MOUNTING SURFACE

DESCRIBE (E.G. CONCRETE*, BRICK, ETC.)

BACK FRAME CENTERED TO

- YES NO

BACK FRAME EMBED CONDITION

- GOOD FAIR POOR

CONCRETE CONDITION

- GOOD FAIR POOR

PIT STYLE

- T-STYLE CONTINUOUS

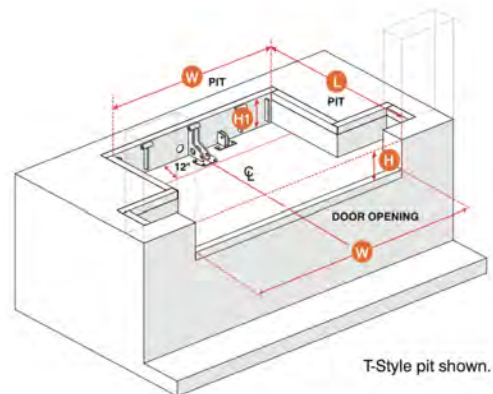

*Concrete must be minimum 8" (203 mm) thick.

3. Grade and Bumper

Grade

DRIVE APPROACH MATERIAL

ASPHALT CONCRETE OTHER (DESCRIBE): _____

IS THE GRADE OF THE DRIVEWAY

LEVEL INCLINE DECLINE (SHOWN BELOW)

GRADE CALCULATION

DOCK HEIGHT (R1)	RISE (R2)	RUN (R3)	% GRADE
------------------	-----------	----------	---------

Sloped Driveway Grade Calculation

Rise is the elevation difference between the parked dock and the driveway surface where the rise is measured. *Run* is the actual distance on the driveway where the rise is measured (i.e. 50 ft. to match the average 'over the road' trailer length).

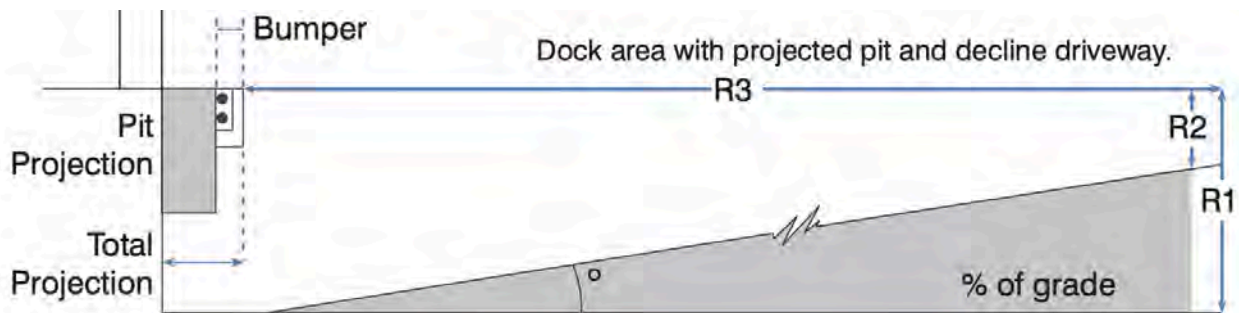

*Example: % of grade = $(R1 - R2) / (R3)$

To determine these totals on site, use a 50 ft. string line. Restrict general access to the dock leveler and loading dock area. While observing all appropriate safety precautions, secure the string line to the dock leveler floor or the top of the lip spool when the dock leveler is in the crosstraffic position. Walk out a distance of 50 ft. and measure the vertical drop to grade. Use level for accurate height level.

Bumper

BUMPER TYPE

NEW REPLACEMENT

STEEL-FACED LAMINATED MOLDED

DUAL FLANGE SINGLE FLANGE NO FLANGE

MEASUREMENTS

DISTANCE BETWEEN BUMPER FACES	BUMPER SIZE (D" x H" x W")
-------------------------------	----------------------------

CENTER HORIZONTAL BUMPER (STEP VAN PROTECTION)

NO YES (SPECIFY):

Wall to Front of Bumper - Common Conditions

Flush is the optimal condition where X (Wall) = 0 and B (Bumper) is the size of the bumper.

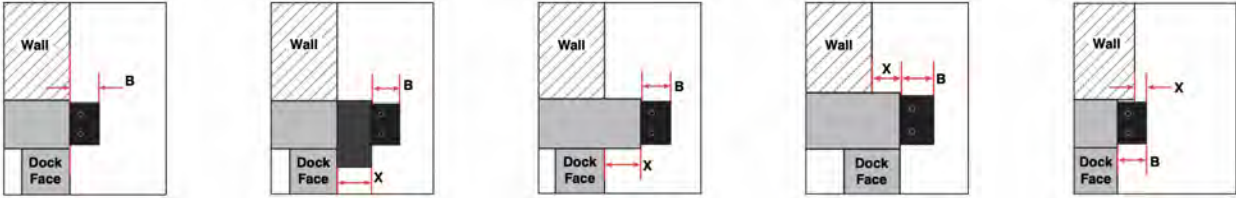

Flush Edge-of Dock Cantilever Wall Setback Wall Overhang
 B= B= B= B= B=
 X= X= X= X= X=

DIMS	TRUCK1	TRUCK2	TRUCK3
H			
W1			
W2			
W3			
L			
A			
B			
C			
D			
E			
F*			
ICC			

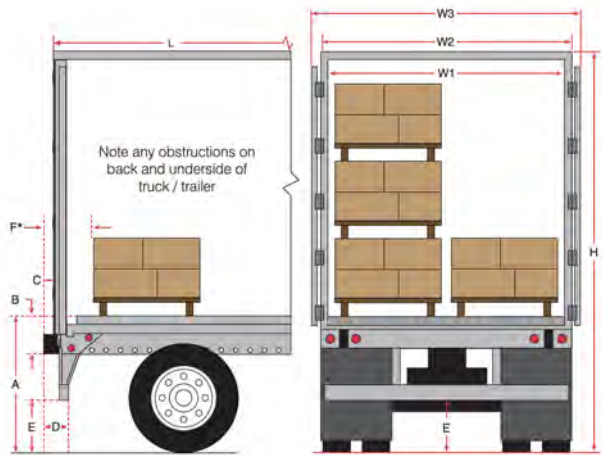

*Minimum of 4 - 6" required for lip overlap. If lip overlap is not achievable, end loading is suggested.

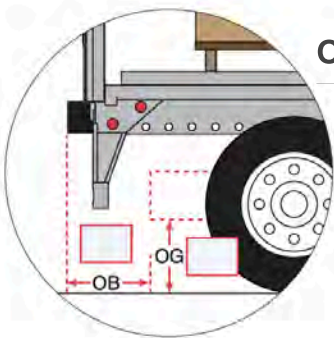

OBSTRUCTION
DESCRIBE:

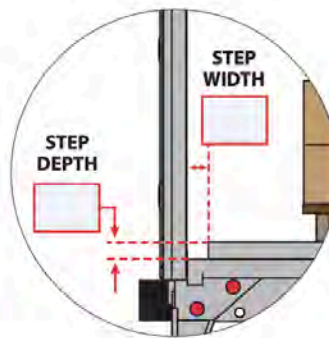

TRUCK WITH REAR STEPS
 YES
 NO

OB = Obstruction to Bumper OG = Obstruction to Ground

4. Truck and Trailer

Truck and Trailer Types

TRUCK TYPE	BED HEIGHT "A"		TOTAL HEIGHT "H"	
	in.	mm	in.	mm
<input type="checkbox"/> STRAIGHT SEMI	48 - 52	1219 - 1321	144 - 162	3.6 - 4.1
<input type="checkbox"/> LOW BOY	19 - 25	483 - 635	144 - 162	3.6 - 4.1
<input type="checkbox"/> OVERSEAS CONTAINER	55 - 62	1397 - 1575	146 - 162	3.7 - 4.1
<input type="checkbox"/> CITY DELIVERY TRUCK	45 - 48	1143 - 1219	132 - 150	3.4 - 3.8
<input type="checkbox"/> REFRIGERATED TRUCK	50 - 60	1270 - 1524	150 - 162	3.8 - 4.1
<input type="checkbox"/> HIGH CUBE	36 - 42	914 - 1067	156 - 162	4 - 4.1
<input type="checkbox"/> FLATBED	48 - 60	1219 - 1524		
<input type="checkbox"/> STEP VAN	20 - 30	635 - 762	102 - 120	2.6 - 3
<input type="checkbox"/> STRAIGHT TRUCK	36 - 48	914 - 1219	126 - 144	3.2 - 3.7
<input type="checkbox"/> PANEL TRUCK	20 - 24	508 - 610	96 - 108	2.4 - 2.7
<input type="checkbox"/> OTHER				

YARD JOCKEYS USED

YES NO

FULL HEIGHT ACCESS REQUIRED

YES NO

FULL WIDTH ACCESS REQUIRED

YES NO

REFRIGERATED TRUCKS USED

YES NO

TRUCK WITH LIFT GATE USED

YES NO

TRUCK / TRAILER DOOR TYPE

HINGED ROLL-UP OTHER

Load Orientation

STACK HEIGHT

SINGLE DOUBLE TRIPLE

STACK WIDTH

SINGLE DOUBLE

5. Dock Area Considerations

Material Handling Equipment

GENERAL INFORMATION

GENERAL INFORMATION

END LOADING

YES

NO

WEIGHT (LB)

MAX. TOTAL AMOUNT OF GROSS LOAD*

WEIGHT OF FORKLIFT

MAX. LOAD

* GROSS LOAD = WEIGHT OF FORKLIFT + MAX. LOAD

Suitable Material Handling Equipment Based on Grade Percentage (General Guideline)

SELECT ALL THAT ARE BEING USED ON SITE

MANUAL PALLET TRUCK: 3%

ELECTRIC PALLET TRUCK: 7%

ELECTRIC FORKLIFT: 10%

GASOLINE FORK TRUCK: 15%

GENERAL INFORMATION

3 OR 4 WHEEL TRUCKS

SOLID OR PNEUMATIC TIRES

SOLID OR PNEUMATIC TIRES

Dock Design Conditions

ENCLOSED WITH OVERHEAD DOORS ABOVE

YES

NO

OPEN PLATFORM

YES

NO

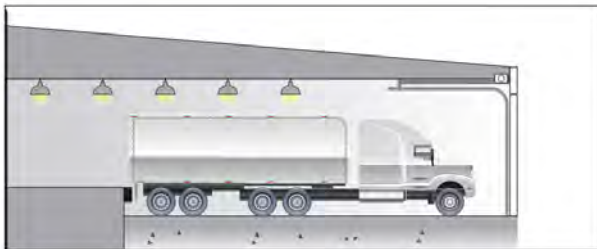

TRAFFIC VOLUME (TRUCKS PER SHIFT)

LIGHT (1 - 3)

MODERATE (4 - 8)

HEAVY (8+)

NUMBER OF SHIFTS PER DAY

ONE

TWO

THREE

DAILY USAGE

FULL TRUCK LOADS*

0-8
0-200

9-16
201-400

17-24
401-600

>24
>600

LOAD CYCLES

* FULL TRUCK LOADS = TRAFFIC VOLUME x NUMBER OF SHIFTS PER DAY

6. General Site Information

Positions

POSITION / BAY NUMBER - PROVIDE PHOTOS OF PRE-EXISTING EQUIPMENT

SITE DATA

MANUFACTURER	MODEL
DECK DIMENSIONS	CAPACITY
SERIAL NUMBER	LIP LENGTH
LIP INTERNAL OR EXTERNAL TO PIT	
<input type="radio"/> YES	<input type="radio"/> NO
LIP BARRIER EQUIPPED	
<input type="radio"/> YES	<input type="radio"/> NO

Vehicle Restraint

MANUFACTURER	MODEL
SERIAL NUMBER	
IS PIT FLOOR CONCRETE (OR DOCK FLOOR IF NO PIT)	
<input type="radio"/> YES	<input type="radio"/> NO
IS PIT FLOOR BRACKET IN PLACE (HVR303 ONLY)	
<input type="radio"/> YES	<input type="radio"/> NO

Controls

MANUFACTURER	MODEL
COMBO OR STANDALONE	VOLTAGE

Seal and Shelter

SEAL / SHELTER TYPE

<input type="radio"/> COMPRESSION SEAL	<input type="radio"/> SHELTER	<input type="radio"/> INFLATABLE	
MANUFACTURER	MODEL		
DESCRIPTION	HEAD MEMBER WIDTH		
OVERALL HEIGHT	OVERALL WIDTH	BOTTOM PROJECTION	TOP PROJECTION
SIDE FACE WIDTH	SIDE FACE BACK	TOP FACE HEIGHT	SIDE MEMBER HEIGHT



Corporate 410 Admiral Boulevard
Mississauga, ON L5T 2N6
t 905.457.3900 f 905.457.2313

USA 9201 National Turnpike,
Louisville, KY 40118
www.bluegiant.com

Blue Giant offers a full line of dock levelers, dock safety equipment, seals and shelters, accessories, ergonomic and scissor lift equipment and industrial trucks. Concurrent with our continuing product improvement program, specifications are subject to change without notice. Please contact Blue Giant for latest information. Some features illustrated may be optional in certain market areas.